

This edition contains highlights and tips for installation of various '14 Forester accessories. Please always refer to the installation instructions found on the Subaru Technical Information Site

### ARTICLES CONTAINED IN THIS ISSUE

CODE	ARTICLE .....	PAGE
(01)	Rear Bumper Underguard ...	1
(01)	Auto Dimming Side Mirror with Approach Lighting .....	2
(01)	Trailer Hitch.....	7
(01)	Remote Engine Start Key Start.....	9
(01)	Remote Engine Start Push Button .....	12
(01)	110 Power Outlet.....	13
(01)	Auto Dimming Home Link Mirror .....	18
(01)	Bumper Cover Installation Tips.....	24
(01)	Sports Grille .....	25

## 01 REAR BUMPER UNDERGUARD

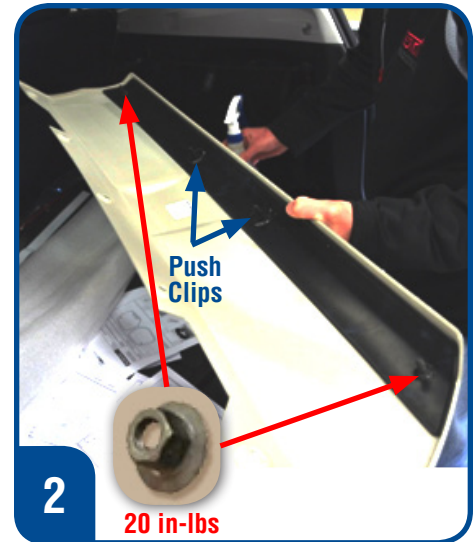
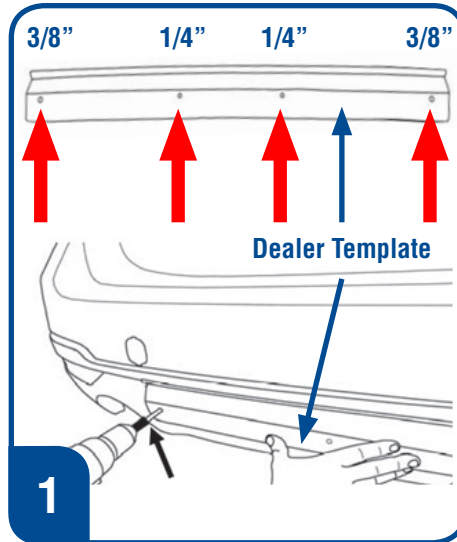

### CAUTION: VEHICLE SERVICING PERFORMED BY UNTRAINED PERSONS COULD RESULT IN SERIOUS INJURY TO THOSE PERSONS OR TO OTHERS.

The Subaru TechTIPS newsletter is intended for use by professional technicians ONLY. Articles are written to inform those technicians of conditions that may occur in some vehicles, or to provide information that could assist in the proper servicing of the vehicle. Properly trained technicians have the equipment, tools, safety instructions, and know-how to do the job correctly and safely. If a condition is described, DO NOT assume that your vehicle has or will have that condition. Impreza, Legacy, Justy, Loyale, Outback, Forester, Subaru SVX, WRX, WRX STI, L.L. Bean, Baja, Tribeca, BRZ, XV Crosstrek and "Quality Driven" are Registered Trademarks.

### SUBARU OF AMERICA, INC. IS "ISO 14001 COMPLIANT"

The international standard for excellence in Environmental Management Systems. Please recycle or dispose of automotive products in a manner that is friendly to our environment and in accordance with all local, state and federal laws and regulations.



QUALITY DRIVEN® SERVICE



**01** AUTO DIMMING SIDE MIRROR WITH APPROACH LIGHTING



1 Release Mirror

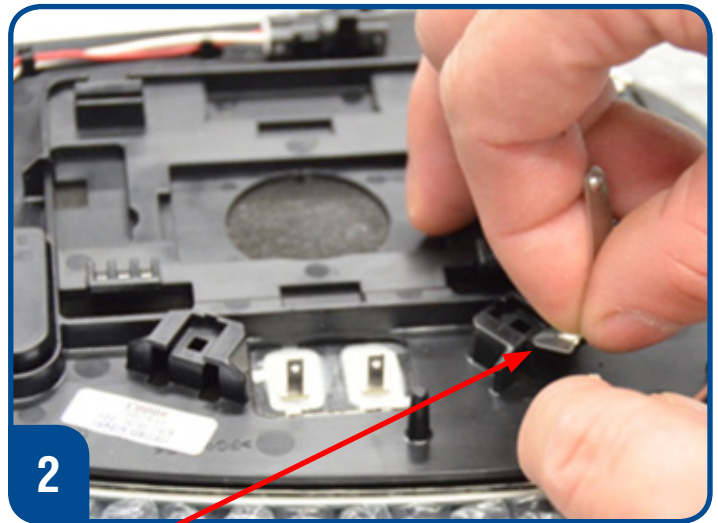

2 Assemble Springs

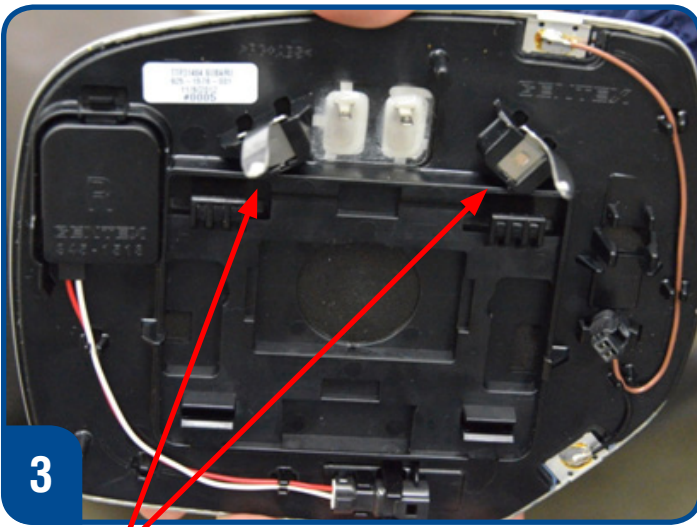

3 Assemble Springs

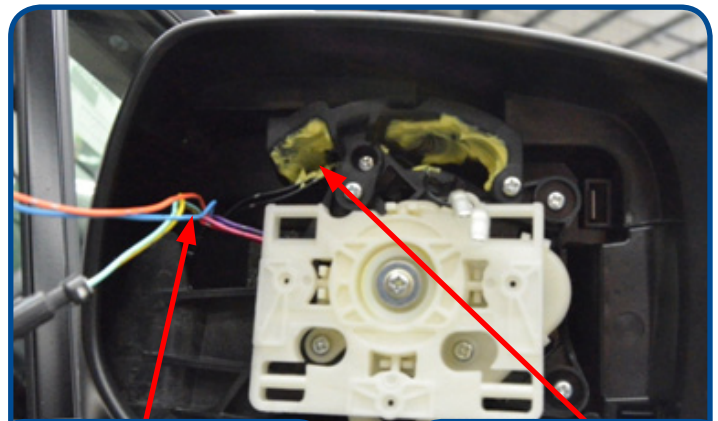

4 Apply Grease



Pre-arranged Connector

**01** AUTO DIMMING SIDE MIRROR WITH APPROACH LIGHTING (CONTINUED)

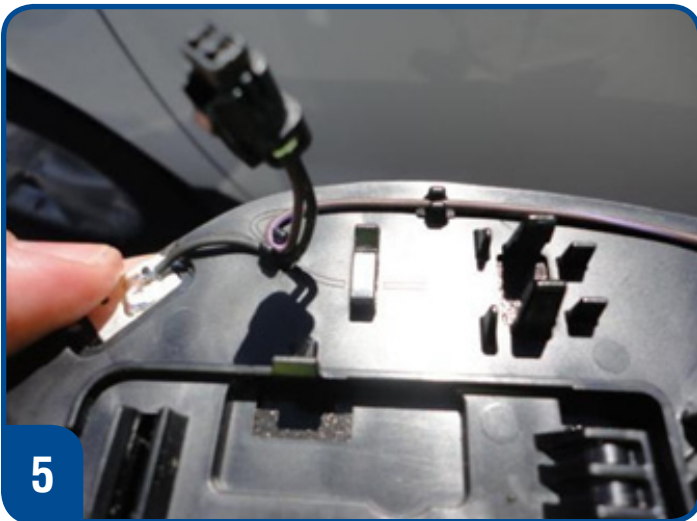

Unclip side harness

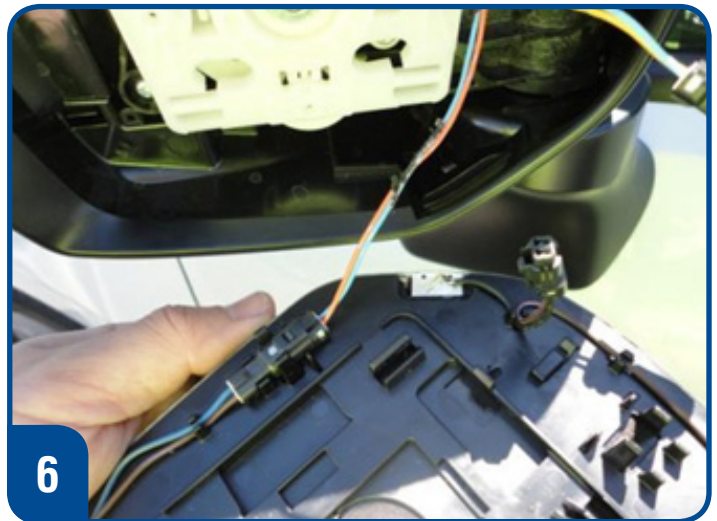

Connect lower harness



Route lower harness through under side clip.

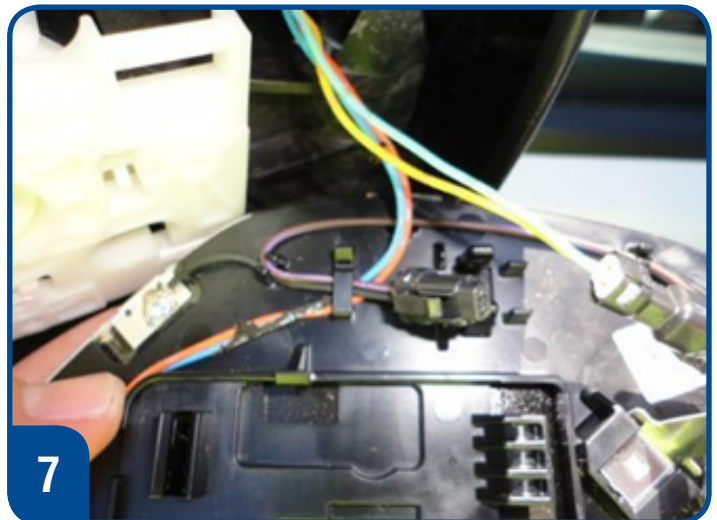

Route side harness under side clip, on top of lower harness.

**01** AUTO DIMMING SIDE MIRROR WITH APPROACH LIGHTING (CONTINUED)

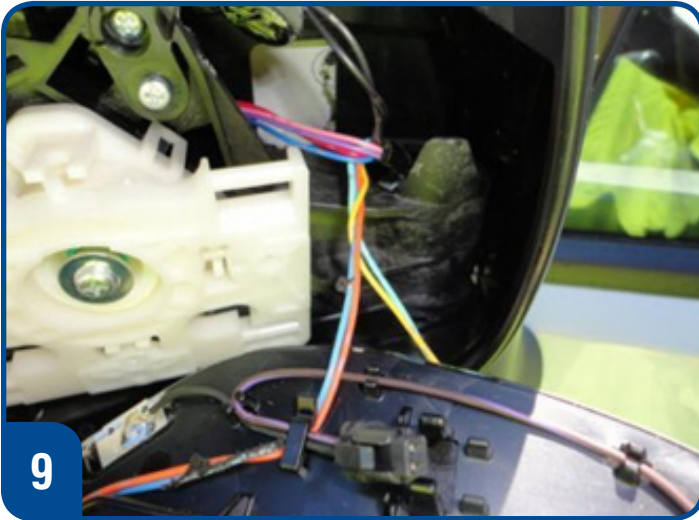

Twist lower harness and side harness together.

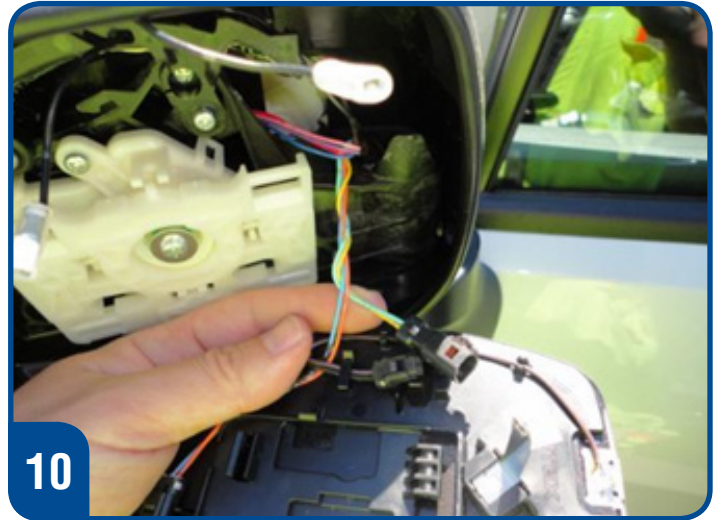

Twist wires two times to take up excess slack.

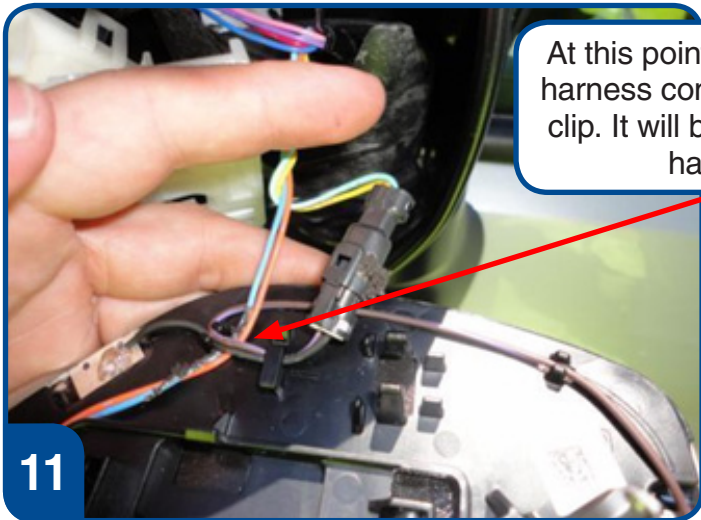

Connect side harness.

At this point its ok if lower harness comes out of side clip. It will be held by side harness

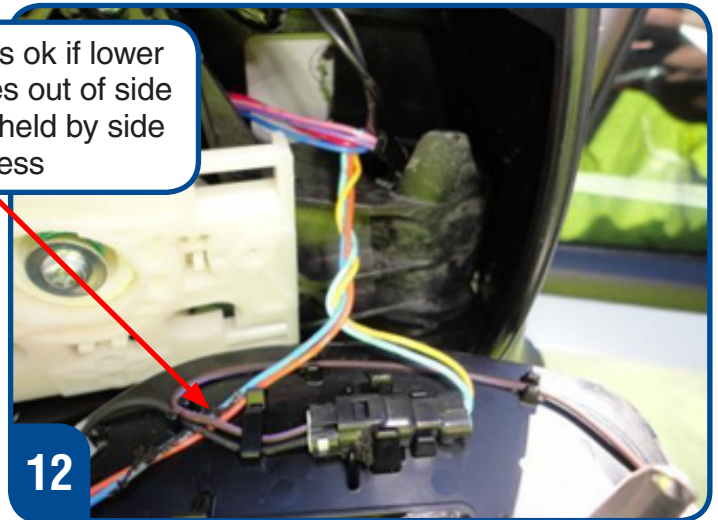

Secure connector in holder.

**01** AUTO DIMMING SIDE MIRROR WITH APPROACH LIGHTING (CONTINUED)

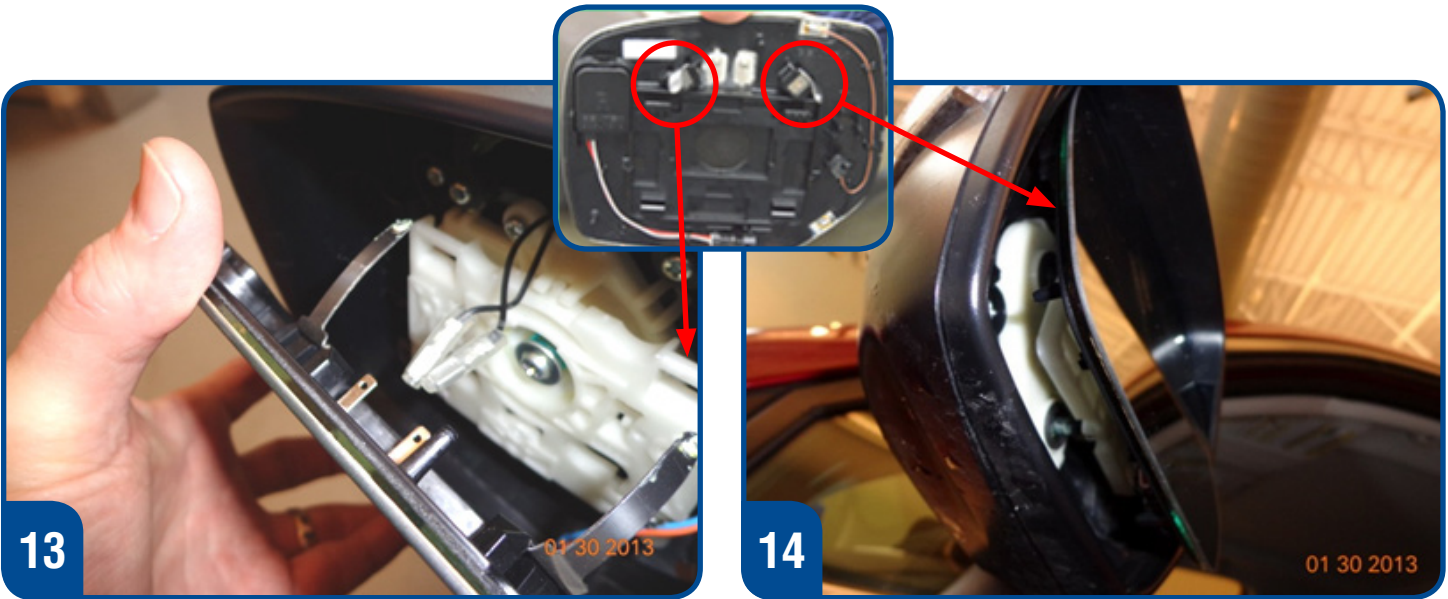

**13**  
Connect Terminals

**14**  
Hook clips to mirror plate.

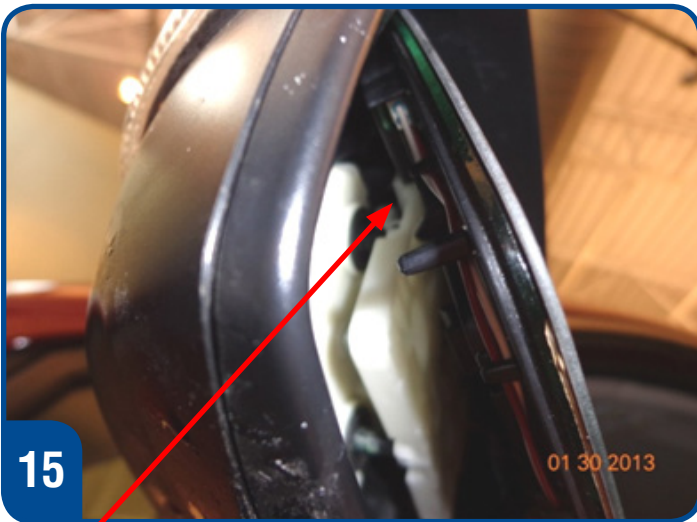

**15**  
Hook Mirror



**16**  
Press Down to Snap & Lock



Harness not visible.



Harness stays back though mirror's entire range of motion.

# 01 TRAILER HITCH

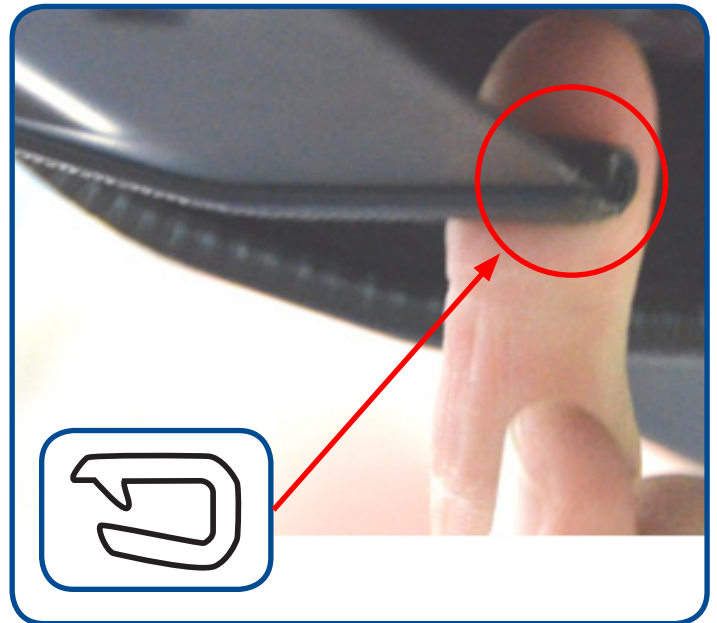
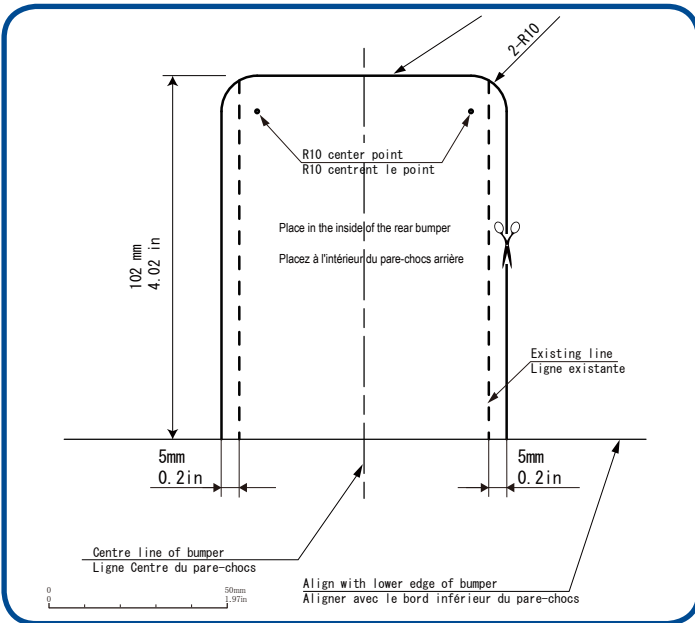

Fascia Cutting Template

Cut-out Trim Orientation



Mount Locations

## 2X for Turbo Models

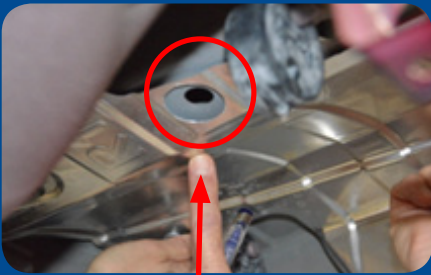

Remove Heatshield/Drill Hole as specified



Mount Bracket and Spacer washer



Mount Bracket and Spacer washer

Continued...

Pre-arranged Connector

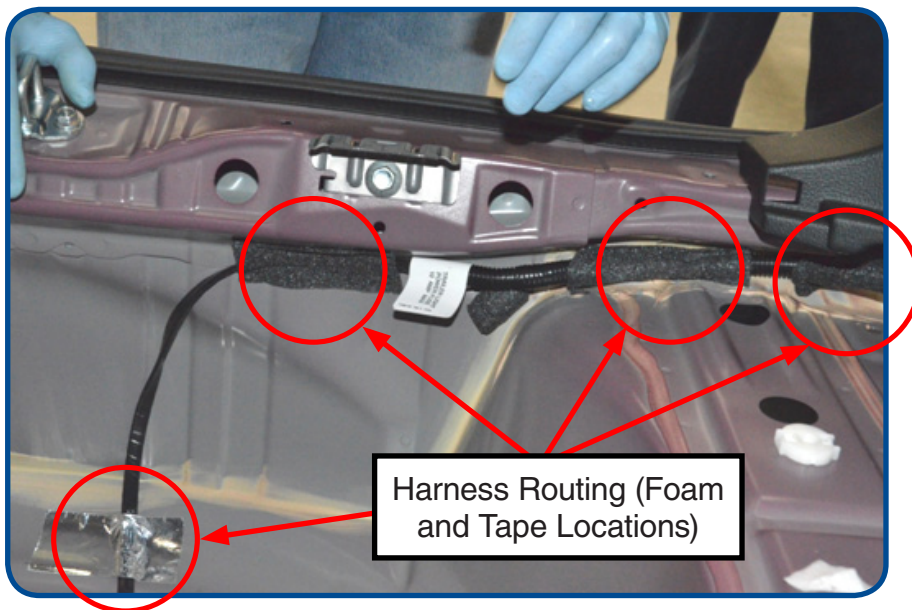
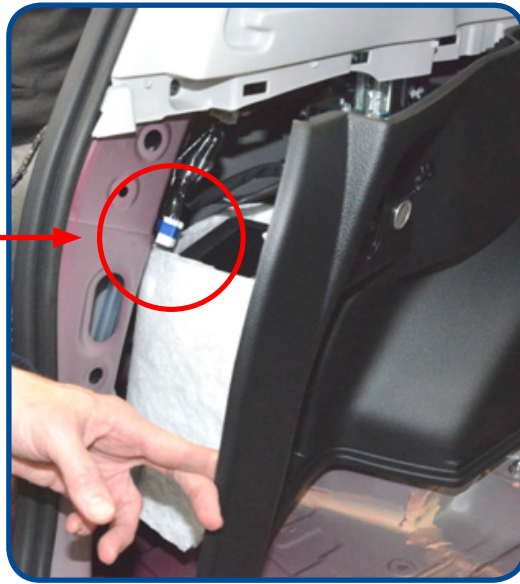

Harness Routing (Foam and Tape Locations)

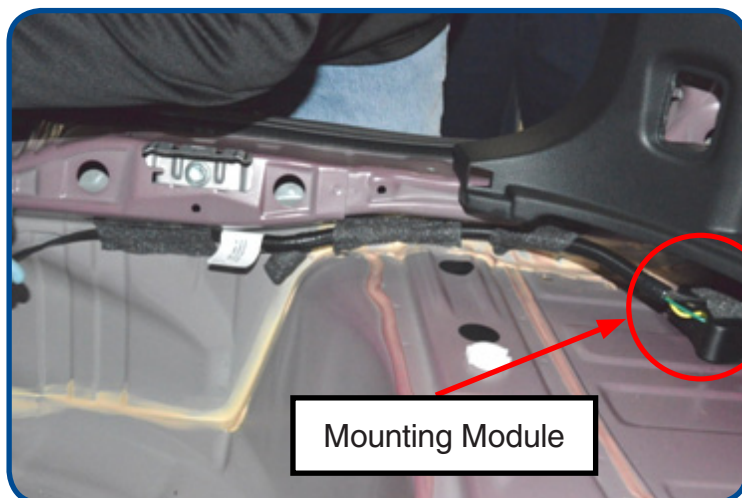

Mounting Module



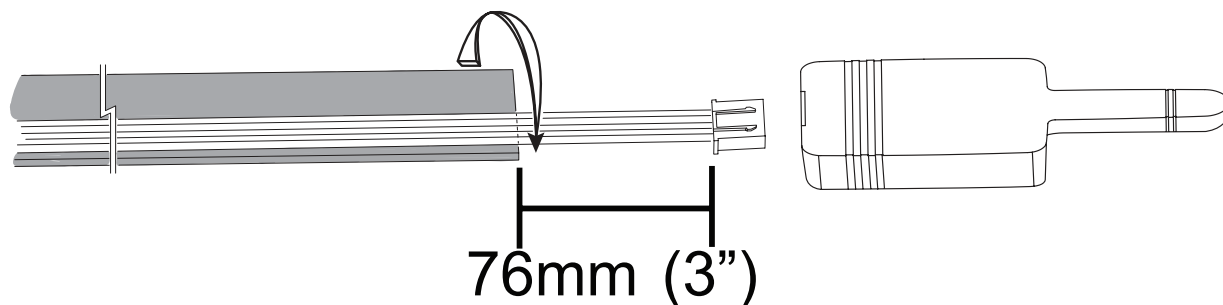

1

Wrap the long piece of foam tape (supplied in the kit) along the length of the wire harness, starting 76mm (3") to the left of the connector.

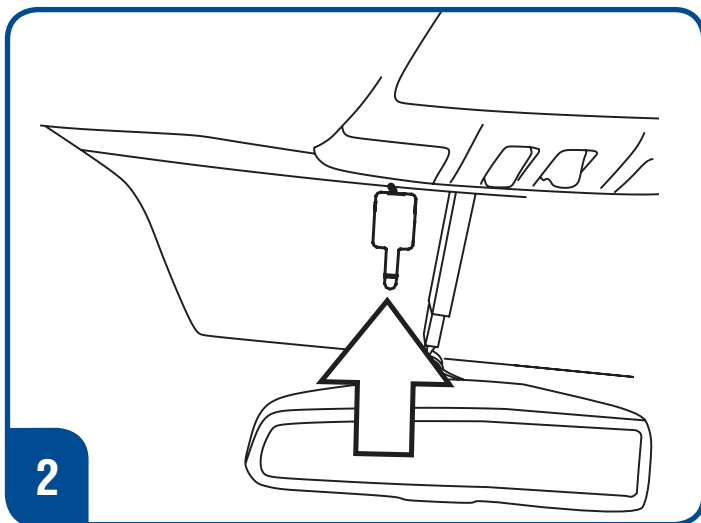

2

The antenna is still mounted 1" to the left on the center line on the windshield.

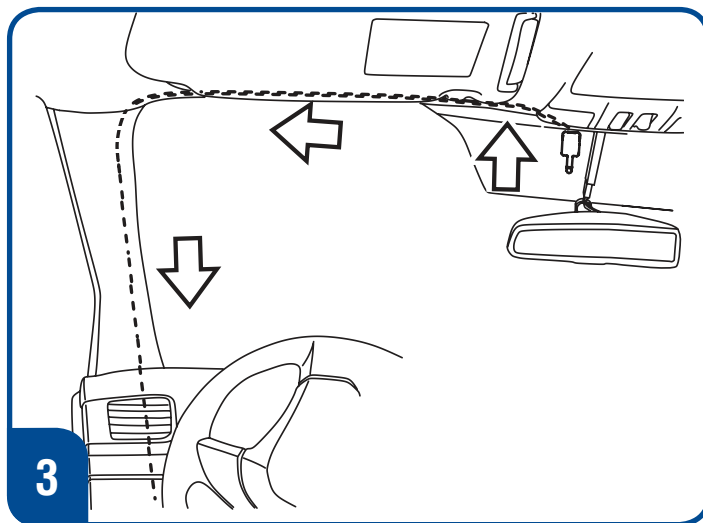

3

Once the foam has been wrapped along the entire length of the harness you may then tuck the harness behind the headliner working towards the LF A pillar.

*Continued...*



The top left corner of the antenna pod should be 20mm (3/4") from the right corner of the A-pillar trim panel in a straight line and 10mm (3/8") down from the headliner to the upper right corner of the antenna pod. The antenna should be level left to right.

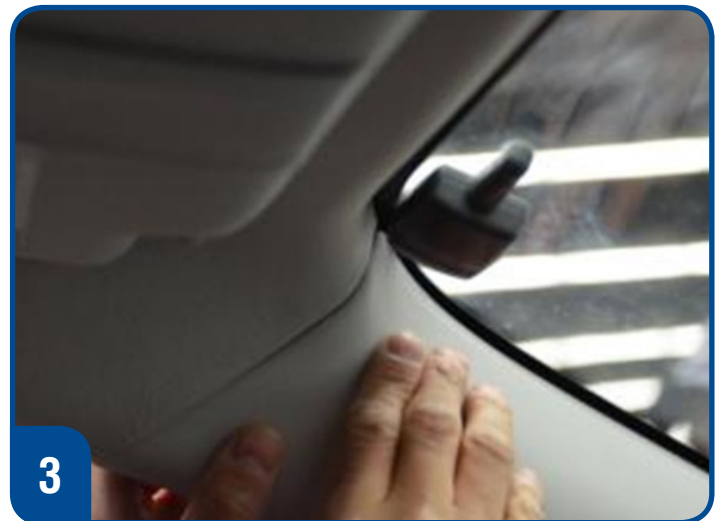
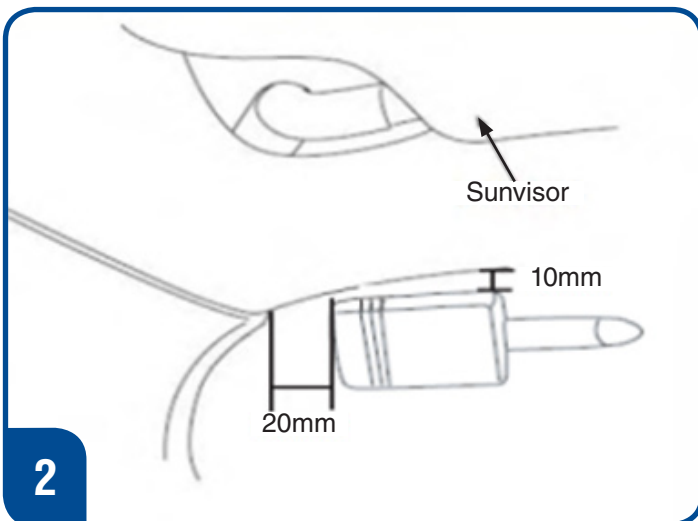



Run the wire harness down the A-pillar and zip-tie in the 6 locations circled in red. Once the 6 locations have been zip-tied then wrap each zip-tie with the supplied foam tape to eliminate the potential for rattles.

## 01 REMOTE ENGINE START PUSH BUTTON

Working back from the glove box area there are 2 tie-off locations behind the dash assembly before the center panel opening. At the center panel opening (where the RES harness is routed underneath the ducts and behind the two metal brackets) zip-tie the RES harness as shown in the lower left hand image.

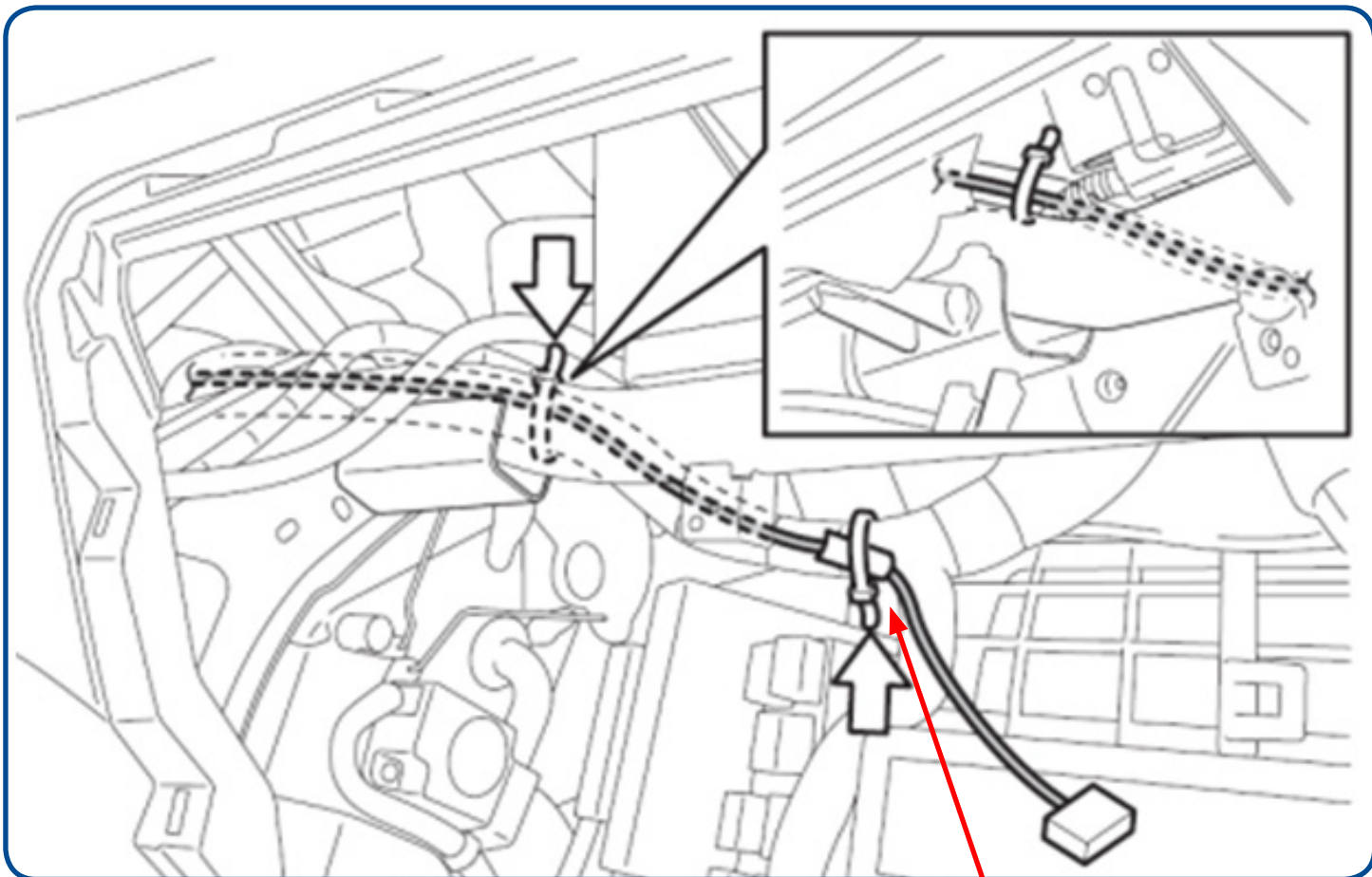

## 01 110V POWER OUTLET



Template and cut orientation is rotated from previous 110V Power Outlet installs. The opening flap is now facing the LF seat. Mount the inverter so that the connector is facing towards the LF seat.



**01** 110V POWER OUTLET (CONTINUED)



Removal of center console for wire harness routing. With both hands grip the side console wings and pull towards you to remove.



Ensure that both yellow retention clips are retained for reinstallation.



Then remove the shift lever console plate.



With the console plate removed the 2 screws for the center console can now be accessed.



Tilt the center console back in order to begin harness routing. Route the wire harness underneath the carpet directly across from the e-brake assembly. Fish the harness underneath the RF seat, out from underneath the carpet flap and plug into the inverter.



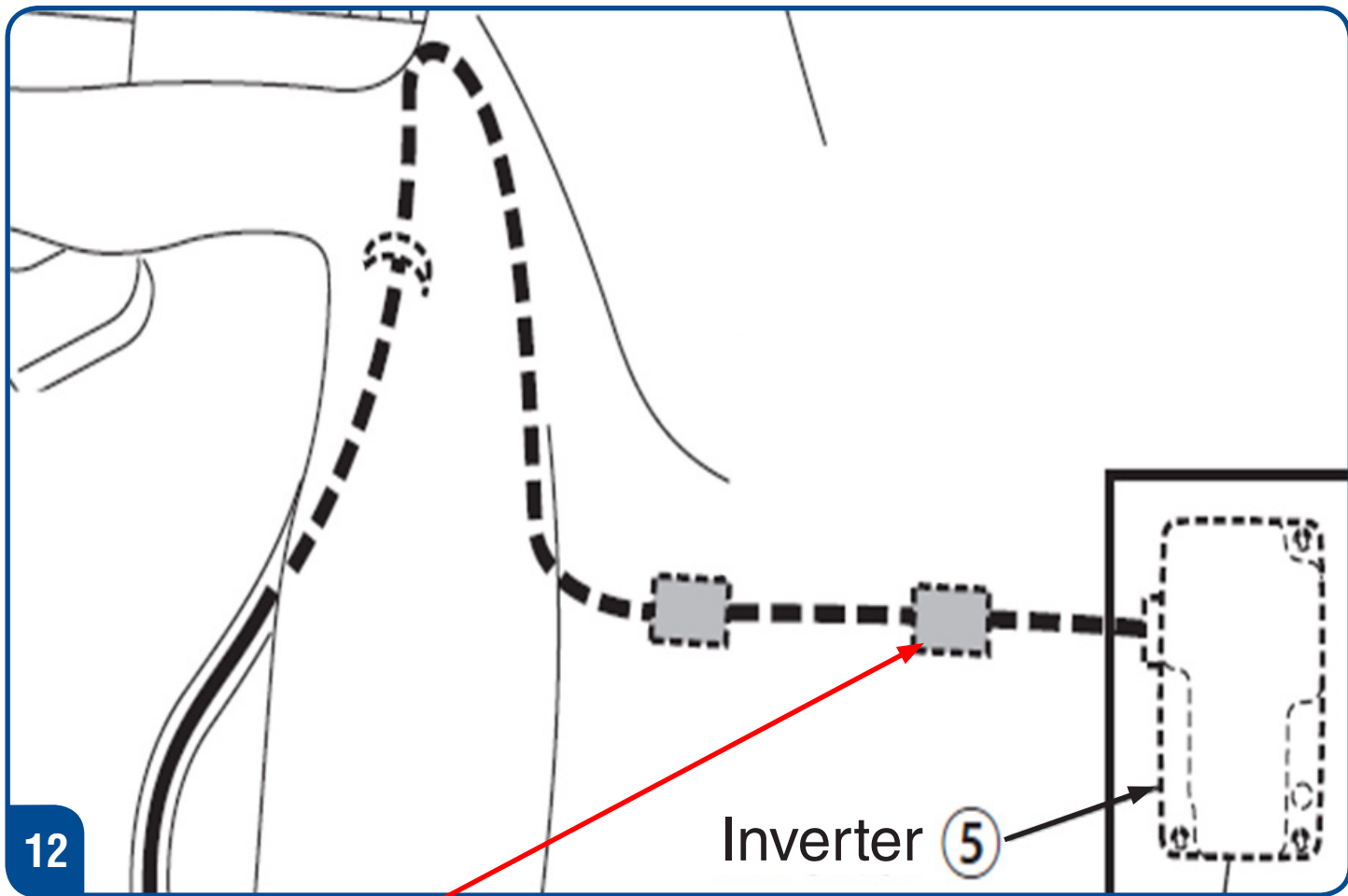

Apply aluminum tape to the wire harness exiting the inverter.



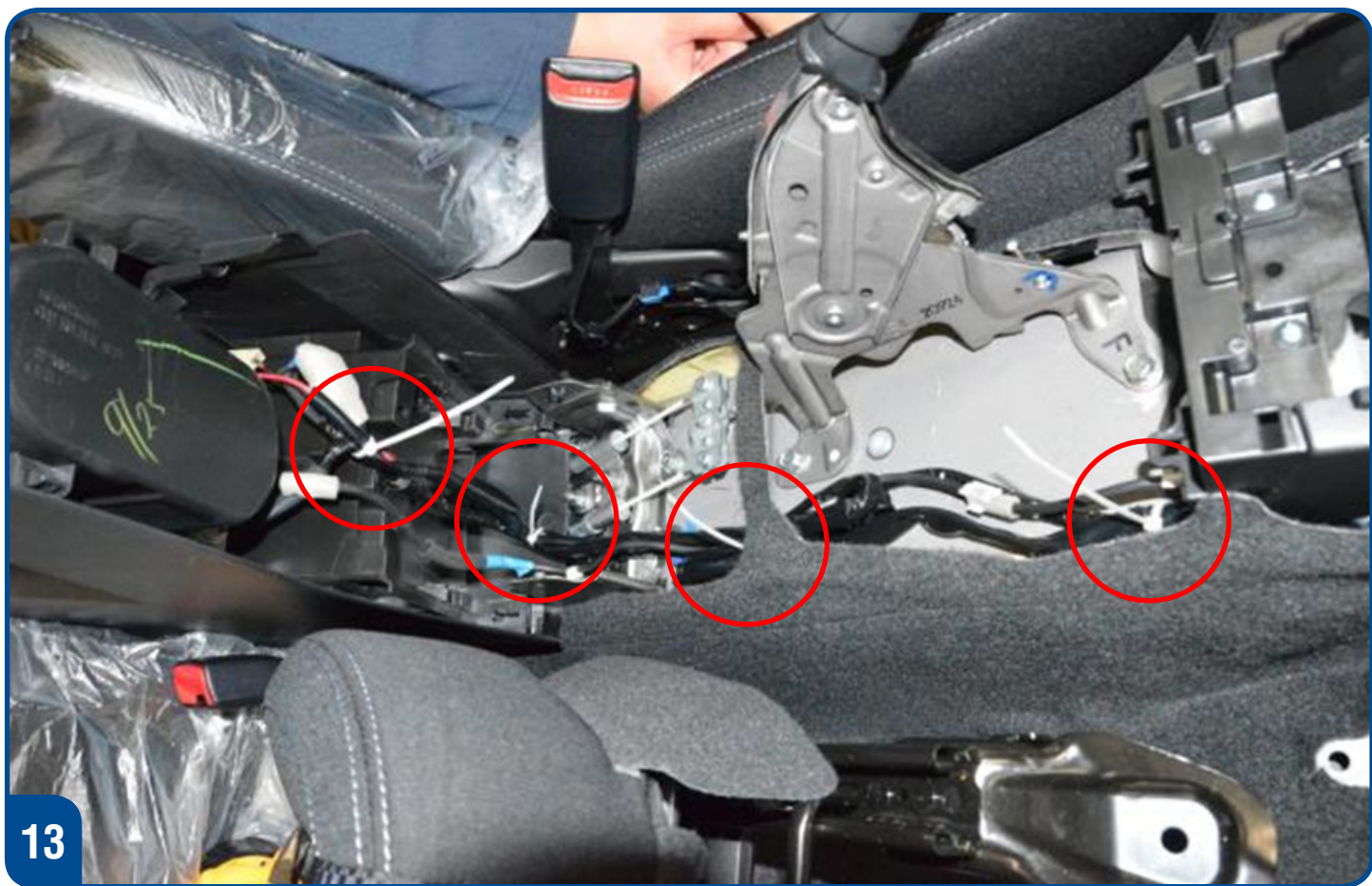

**13**

Four tie-off locations circled in red for securing the wire harness underneath the center console.

EyeSight Equipped



Auto Dimming Home Link Mirror



Carefully Pry off the Cover



Apply protective tape to the eye sight camera openings. **DO NOT TOUCH THE LENSES**



EyeSight Equipped



Using a 8mm socket remove the Eye Sight cover retaining bolts (2)



Carefully support the headliner here when pulling down on the cover.



Carefully pull down on the cover from the headliner to remove the cover from the headliner. Support the front of the cover when removing.

EyeSight Equipped



**DO NOT TOUCH THE LENSES**



Remove the original mirror



Locate the windshield upper shade center mark to align the mirror harness and cover



**DO NOT TOUCH THE LENSES**

EyeSight Equipped



Locate the OE wiring harness to connect the A/D / H/L mirror. **Note:** the connector is taped to the EyeSight wiring harness using “black” tape. The “black” electrical tape will not break away like the “blue” tape and must be carefully cut to allow the connector harness to extend closer to the opening.



Supplemental Instructions to allow for easier access to pre-arranged connector.

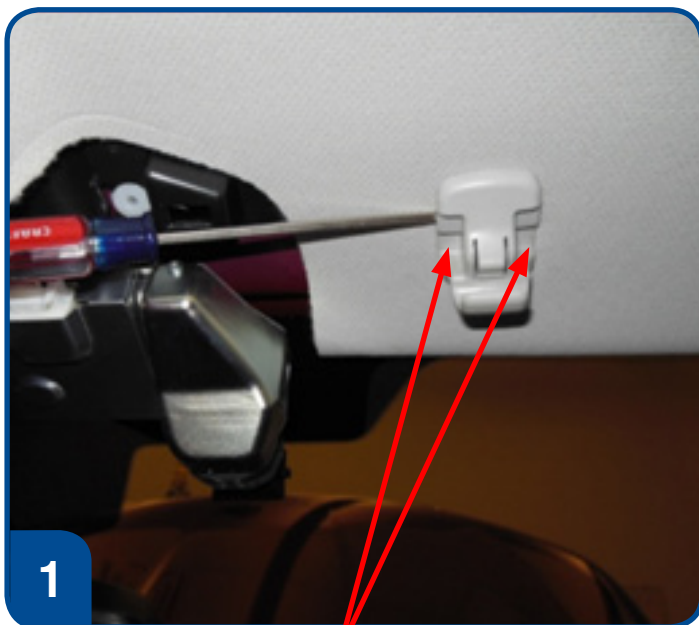

Remove the sunshade holder using a small screwdriver in the locations shown



Remove the sunshade (2) Phillips screws



Mirror connector

Supplemental Instructions to allow for easier access to pre-arranged connector.

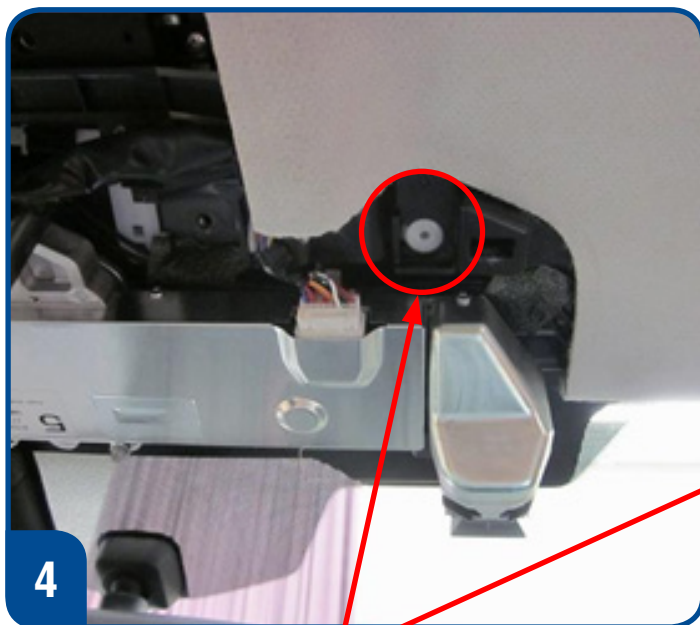

Remove this clip to allow the headliner to hang down to access the connector without damaging the headliner



Carefully access the connector without damaging the headliner

## 01 BUMPER COVER INSTALLATION TIPS



1

Clean bumper surface with 70% -90% Alcohol using a clean towel.



2

Temperature range 60 -110 degrees F.



3

Align Center gate striker



4

Remove tape cover #1 and ensure the edge (lip) fits the bumper contour all the way across, edge to edge.

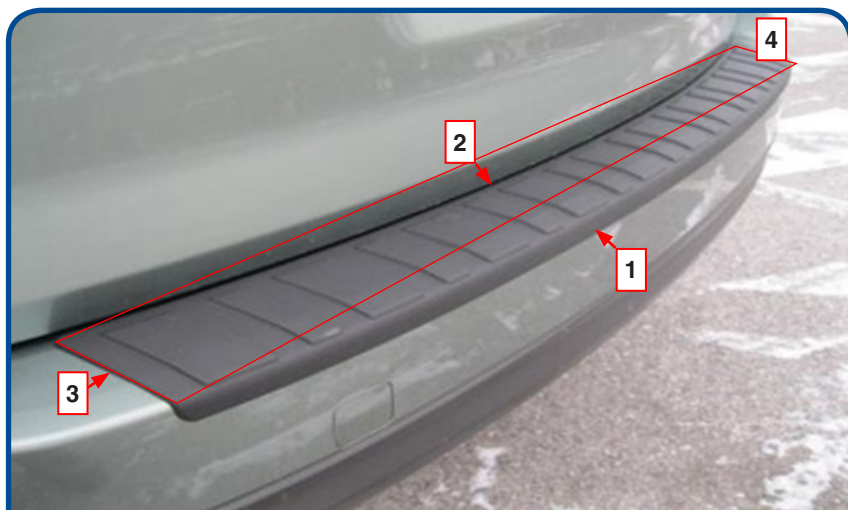

5

Pull the tape covers using the following steps



6

After all tape covers are removed apply 15lbs. of pressure for 10 seconds to entire bumper cover.



**Kit Contents**

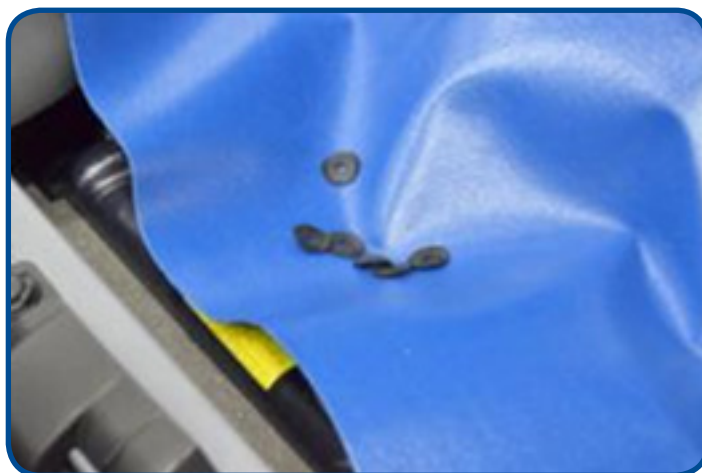

(8) Washers

**Lower Grille Section Removal**

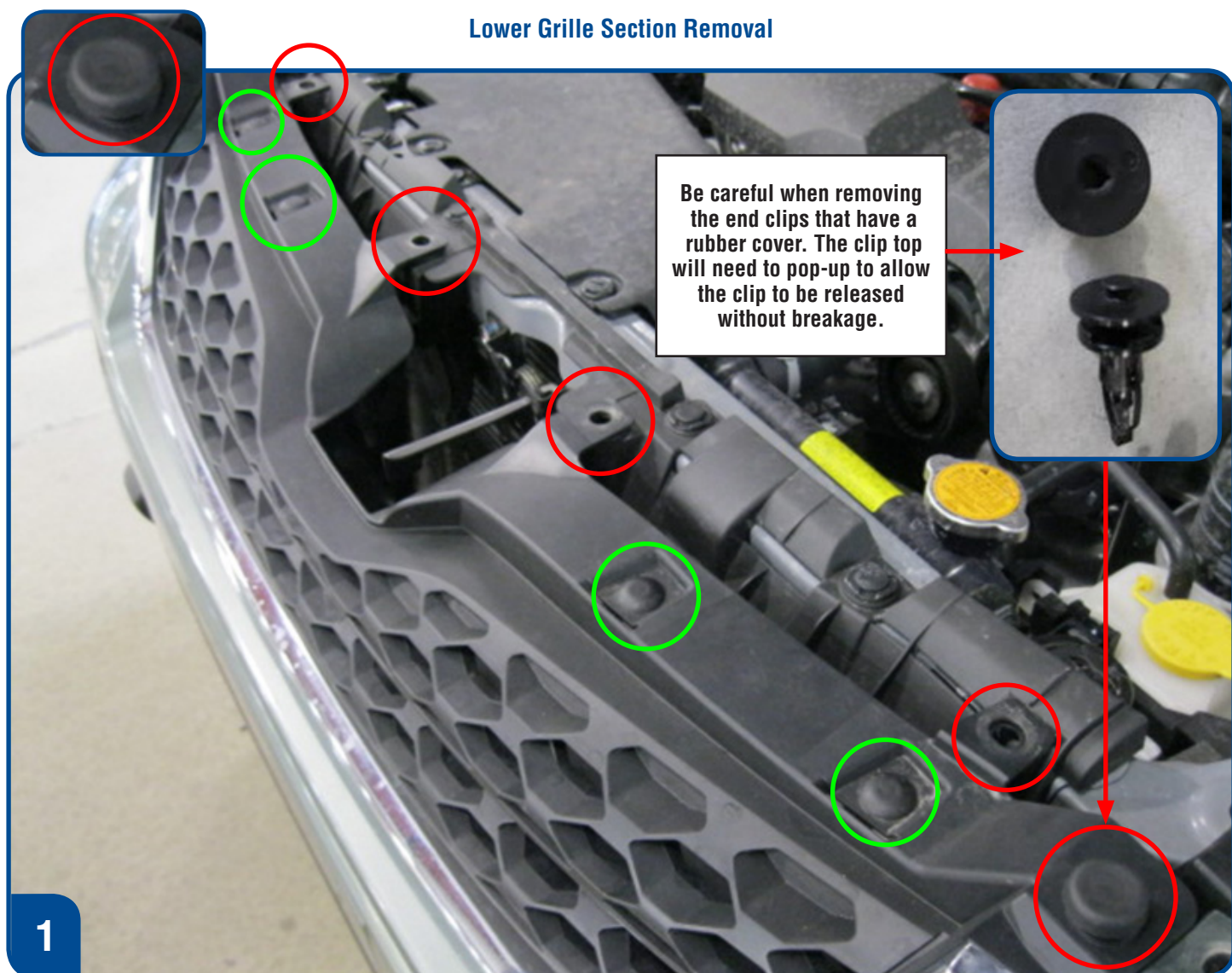

Remove these clips to release the lower grille assembly (red) and remove the dust covers (green). Save to re-use when installing the new sport grille.

Lower Grille Section Removal

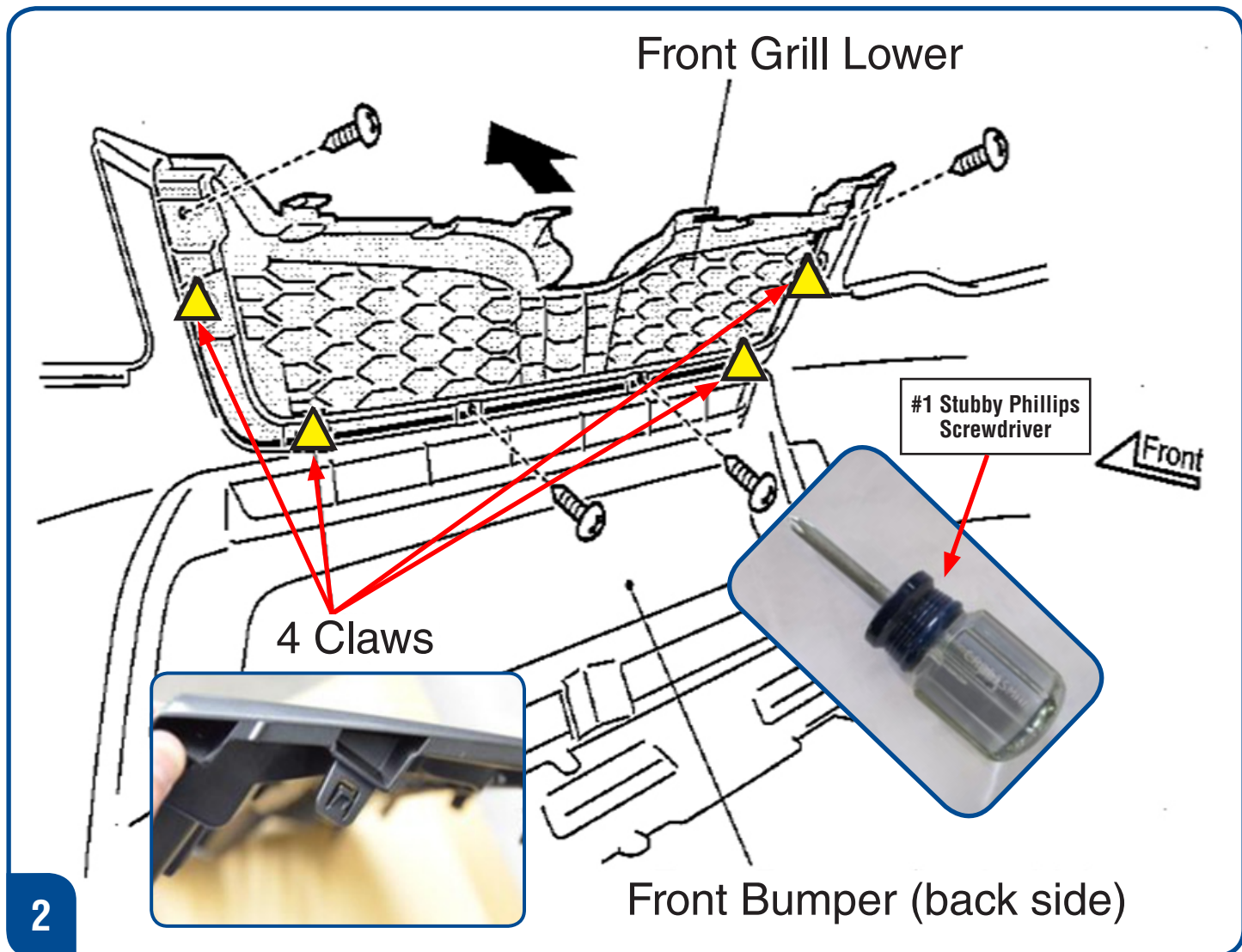

Carefully pull the grille free of the retaining claws after removing the screws without scratching the bumper skin painted surfaces.

Upper Grille Section Removal

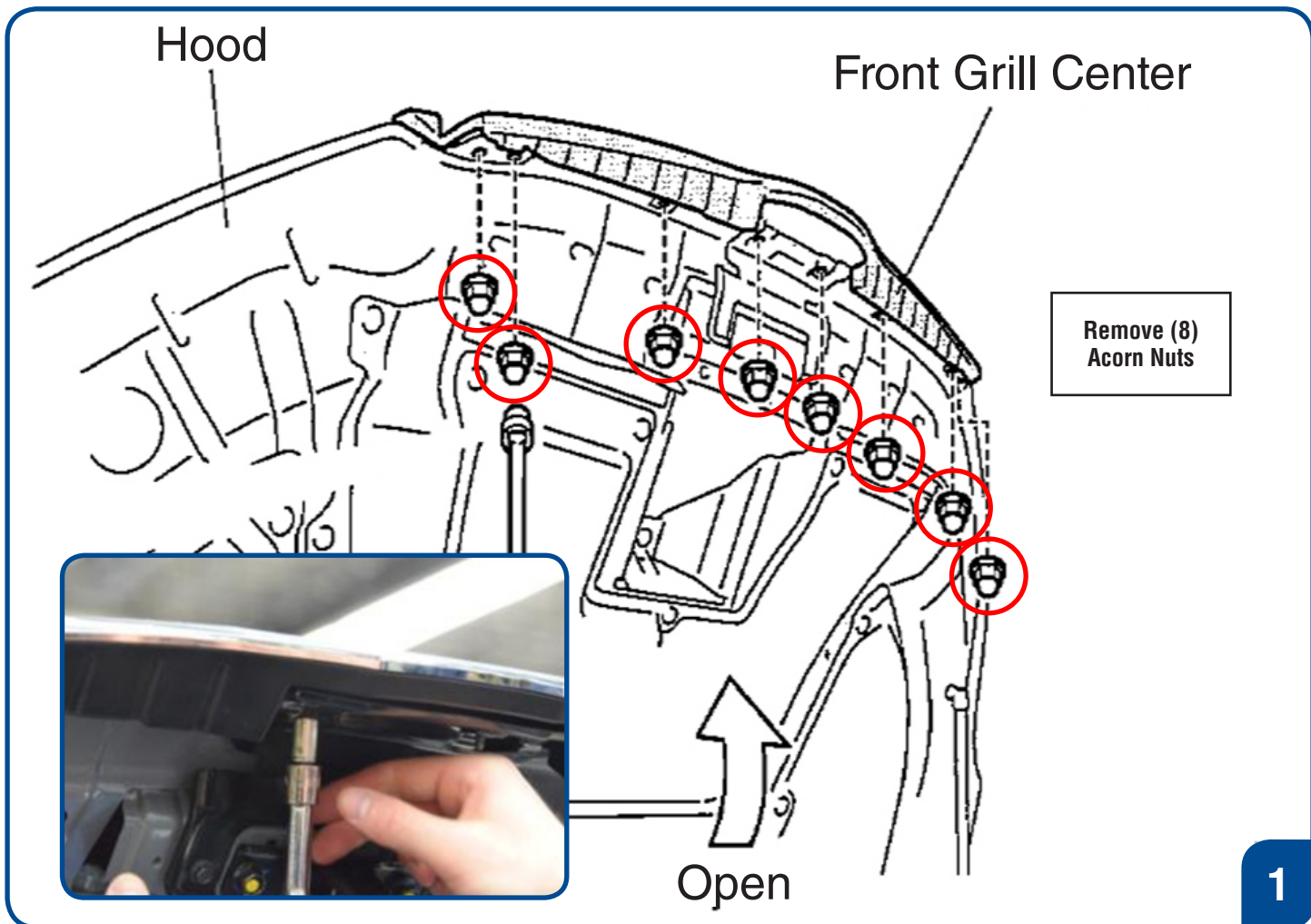

Do not allow any of the nuts to drop into the engine compartment.

**Upper Grille Section Removal**

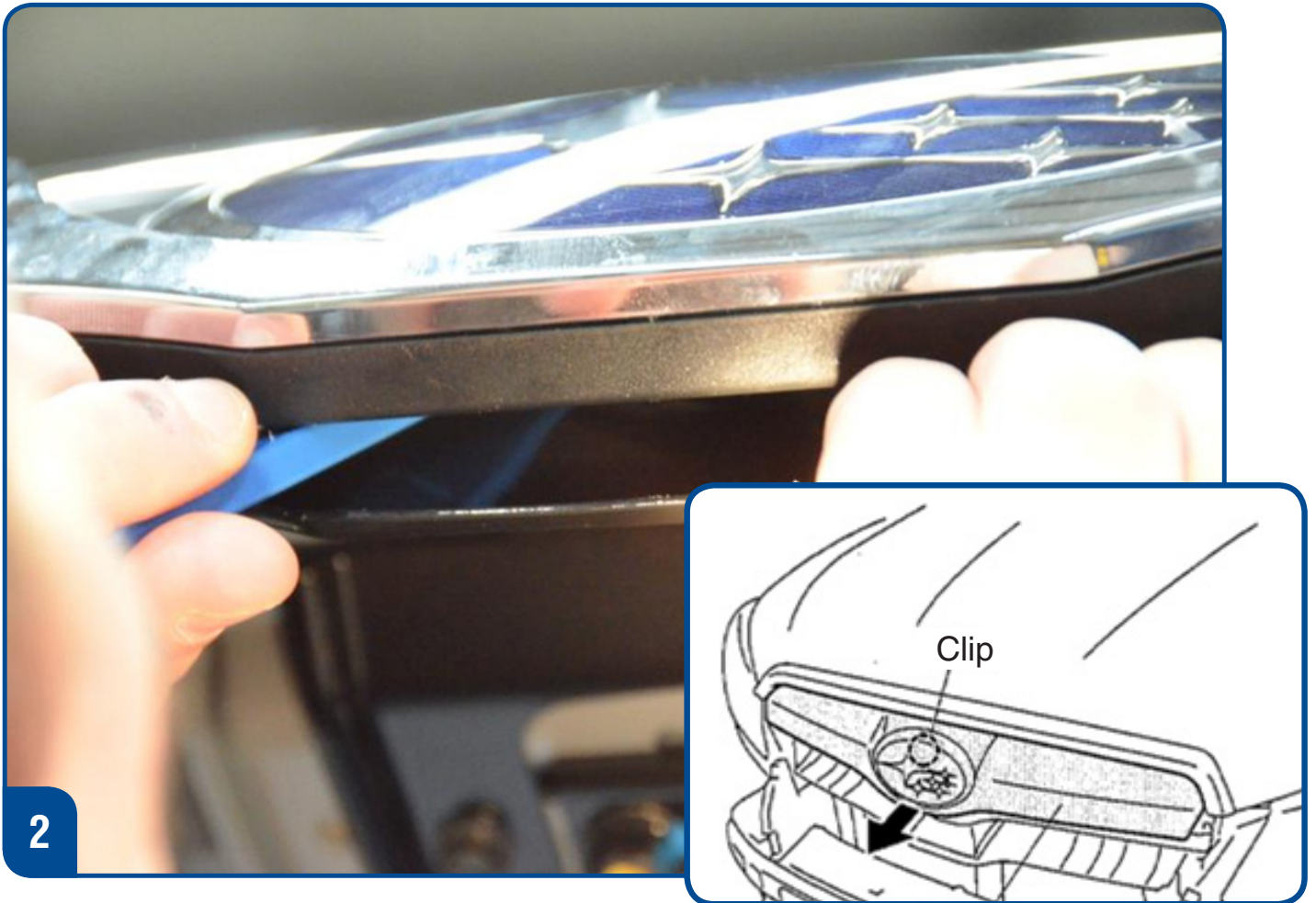

**2**

Recommend closing the hood to apply the required force to remove the upper grille section held in place by (1) center clip.

Carefully pry “up” in the center area under the Subaru Emblem on the upper grille section to unseat the center clip.

### Upper Grille Trim Removal

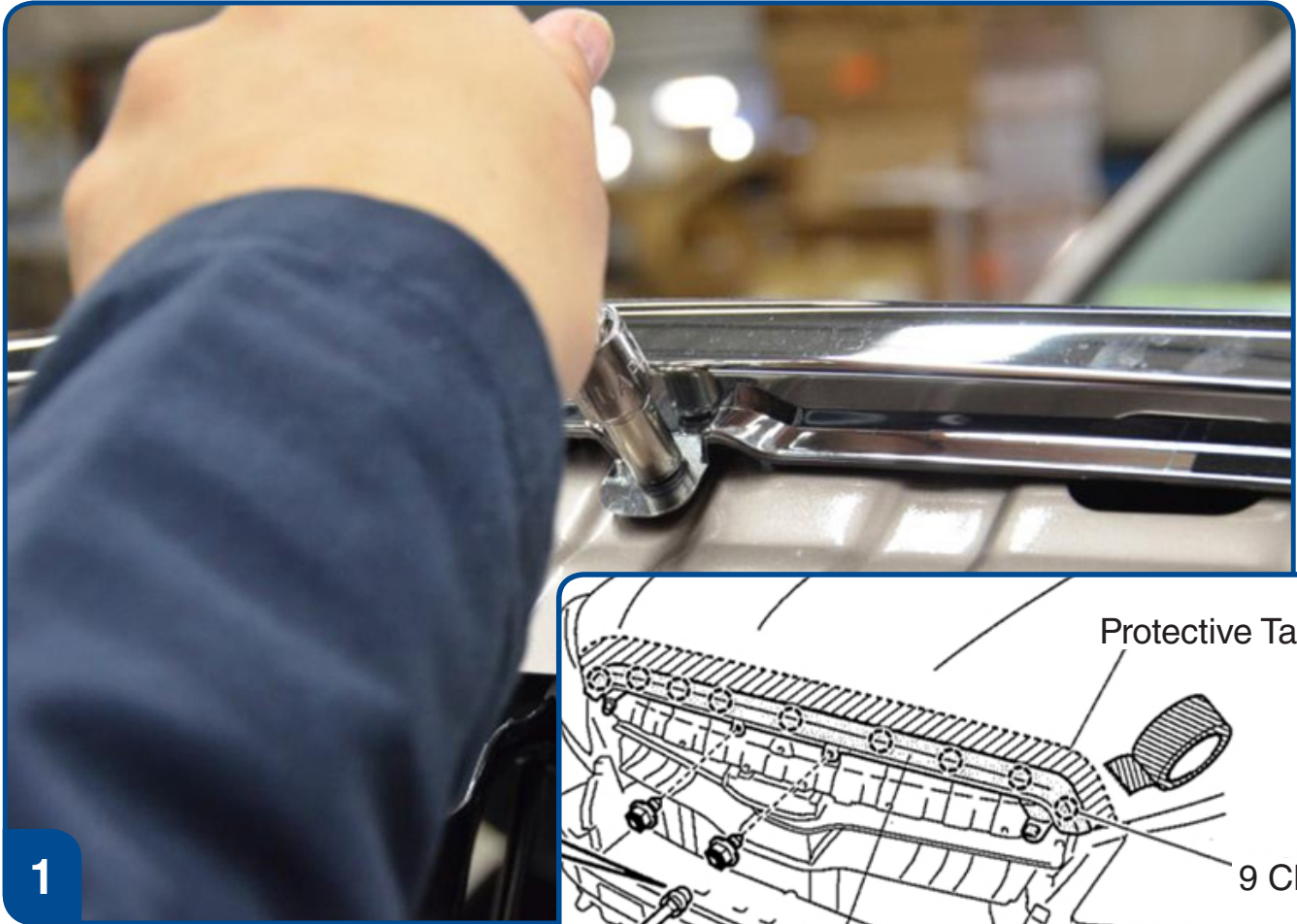

It is easier to remove the upper grille trim with the hood closed to all for a better grip and minimize the possibility of damaging the hood.

Remove the (2) 8mm screws and carefully remove the upper grille trim.

**Note: Ensure protective tape is used on the hood to prevent scratching.**

**New Upper Grille Trim Installation**



Transfer the (2) end slide bolts(studs) and sealing washers to the new upper grille trim section.

**New Upper Grille Section Installation**



**1**

Transfer the (2) slide bolts(studs) and sealing washers to the new upper grille section.



**New Upper Grille Section Installation**

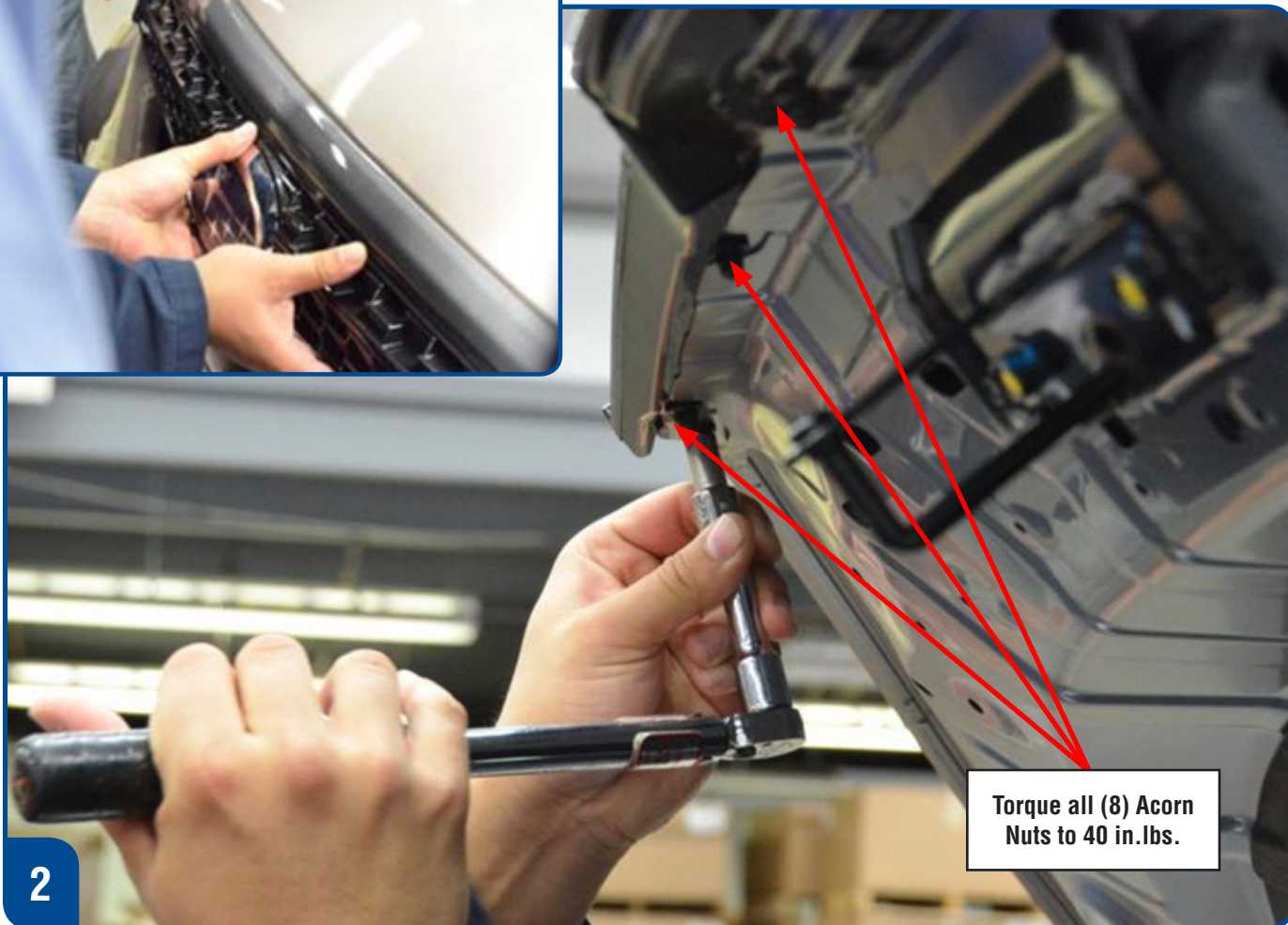

**Torque all (8) Acorn Nuts to 40 in.lbs.**

**2**

**New Lower Grille Section Installation**

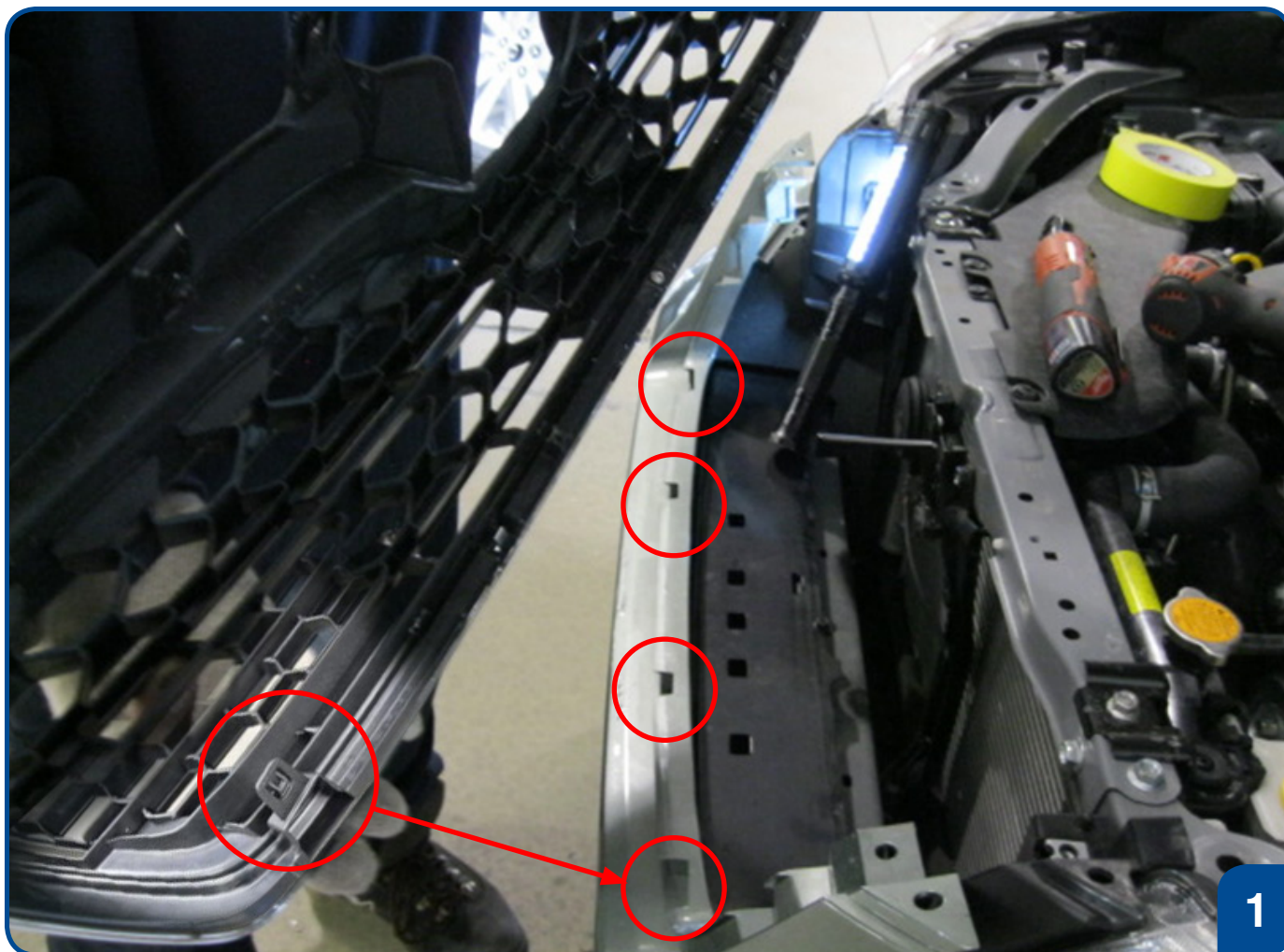

Carefully insert the new lower section grille claws into the bumper slots. Check to ensure fully locked in place. Do not scratch the painted bumper surface.

**New Lower Grille Section Installation**

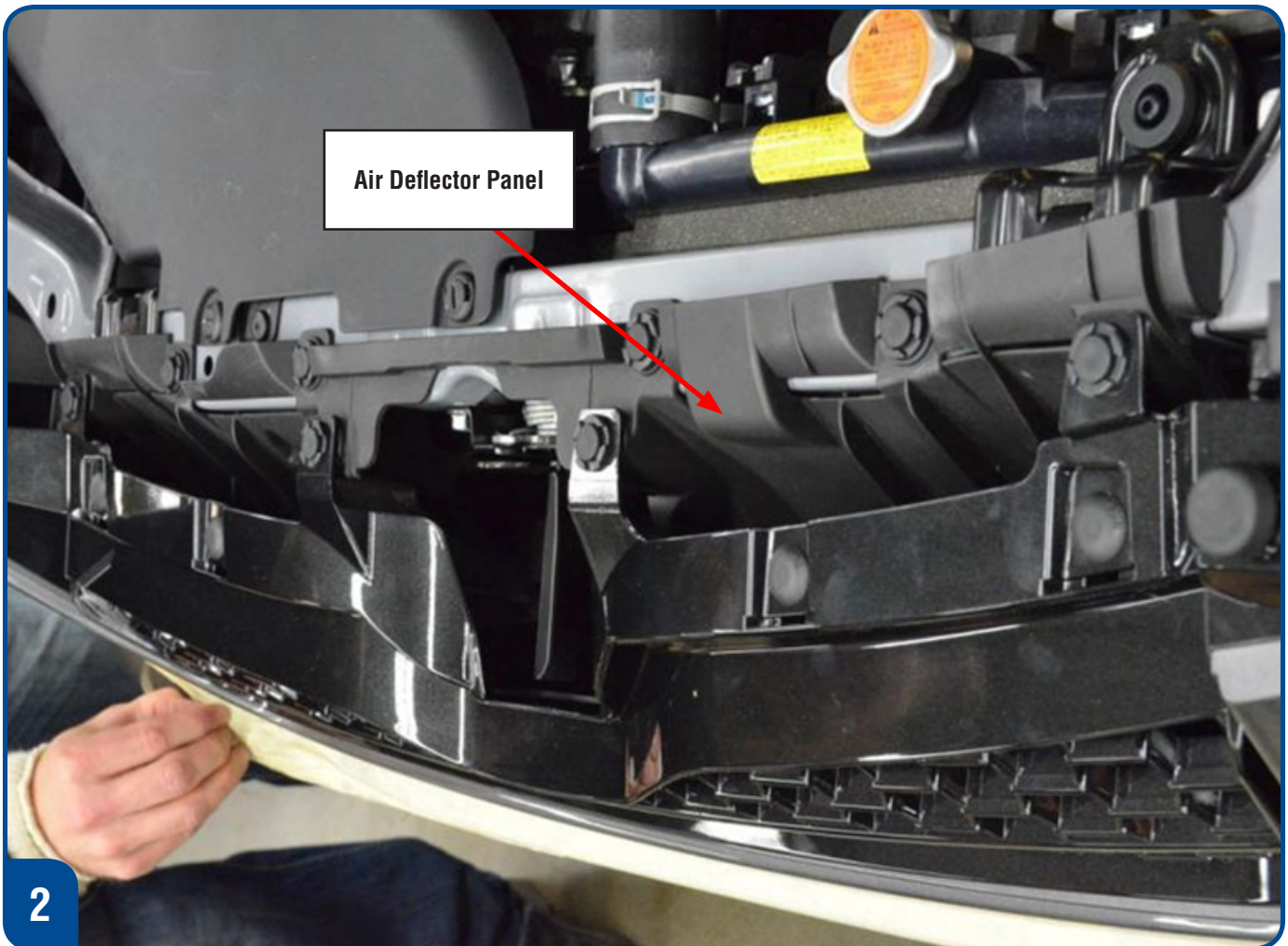

Reinstall the air deflector (4) clips and the upper grille (4) clips including the (4) dust covers.