



UI Bulletin #110M

Subject: **Upfitter Auxiliary Switches (RPO 9L7)**

Models Affected: Chevrolet Silverado
GMC Sierra Light Duty Models (1500-3500) *
(does not include the new 1500 series body styles)

Model Years: 2014 – 2019

Date: October 7, 2013

Revision Date: November 15, 2018

ADVISORY:

NOTE: THIS BULLETIN SUPERCEDES UI110L...PLEASE DISCARD ALL PREVIOUS VERSIONS

Condition/Concern:

For the 2014/15 Full-size trucks (1500 fleet/work 2500/3500HD), built with the regular production option (RPO) 9L7 (auxiliary switch bank), this switch bank replaces the standard switch bank located just below the Climate Controls (refer to figure 1) and is intended specifically for adding controlled features/functions from inside the cab.

These switches are configurable such that they can provide either Battery or Ignition 12v+ outputs. The configuration is accomplished by the **RELOCATION** of two fuses in the Under-hood Electrical Center (UEC). The configuration, be it for battery or ignition is done in pairs. Fuse placement will provide either the battery or ignition activation of the output relays for switches 1 and 2 or switches 3 and 4, depending on the locations of the two fuses.

NOTE: Vehicles can NOT be retrofitted to include this option if not built with it.

NOTICE:

*For vehicles equipped with the switches labeled "Aux" built prior to the date(s) shown in the table below, you must contact your local GM dealer to confirm that Customer Satisfaction Campaign (CSC) #14284 has been performed on the vehicle, if not, the vehicle must be taken to a GM dealer to have CSC #14284 performed. This campaign **MUST** be completed **PRIOR** to proceeding with any reconfiguration of fuses located in the Under-hood Electrical Center (UEC).*

NOTE: refer to Service Update bulletin #15411 for more information if UEC is missing the fuses and relays.

Vehicle Breakpoint Information				
Model Year	Model	Plant	Plant Code	Date
2015	Chevrolet Silverado 1500 GMC Sierra 1500	Fort Wayne	Z	Feb. 2, 2015
2015	Chevrolet Silverado 1500 GMC Sierra 1500	Silao	G	Feb. 2, 2015
2015	Chevrolet Silverado 1500 GMC Sierra 1500	Flint	F	Feb. 2, 2015

General Motors Upfitter Integration

<http://www.gmupfitter.com> • 1-800-875-4742 (Upfitter Hotline)

Switches/Relay outputs:



Figure 1
(4 switch configuration shown)

The outputs from the switches are located inside the cab into the LH IP Junction Block (IECM (X61A)). Refer to Figure 2



Figure 2

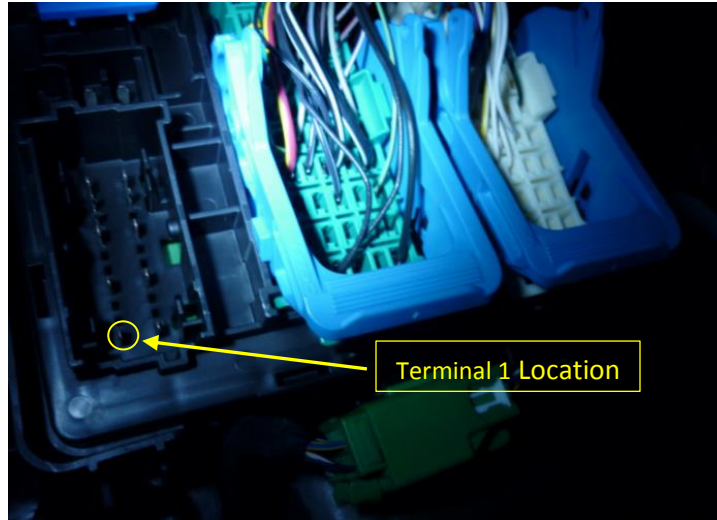

Figure 3

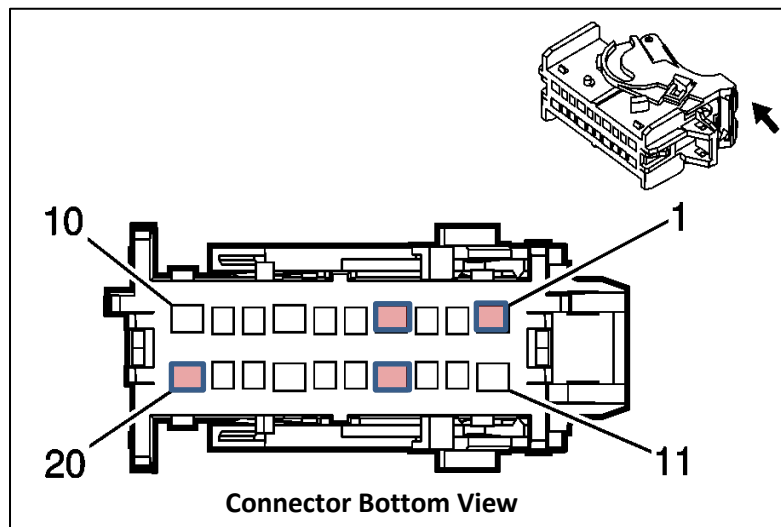

Figure 4

Pin #1, 4, 14 and 20 are used for Upfitter added/configured circuits

Connector Part Information:

- Harness Type: Upfitter
- OEM Connector: 15547108 (This connector and associated component are available through an after-market supplier (<http://www.terminalsandconnectors.com/>))
- Service Connector: Kit P/N 19328970 (Includes Connector body and Lock Lever)
- Description: 20-Way F 1.5, 2.8 Series (BK)

General Motors Upfitter Integration

<http://www.gmupfitter.com> • 1-800-875-4742 (Upfitter Hotline)

Terminal Part Information							
Terminal Type ID	Terminated Lead	Diagnostic Test Probe	Terminal Removal Tool	Service Terminal	Tray	Core Crimp	Insulation Crimp
I	13575832	J-35616-35 (VT)	J-38125-11A	7116-4112-02	9	C	D
II	13578892	J-35616-2A (GY)	J-38125-11A	7116-4101-08	9	E	A

Refer to the connector pin-out table for connector and terminal part number information (next page).

Available for order at GM dealers...dealers need to order on a DRO (Daily Replenishment Order)

X61A Junction Block - Instrument Panel X7

Pin	Size	Color	Circuit	Function/Fuse Rating	Terminal Type ID	Option
1	0		968	Upfitter Provision (30amp) Aux Switch 4 Output	I	9L7
2-3	-	-	-	Not Occupied	-	-
4	0		967	Upfitter Provision (30amp) Aux Switch 3 Output	I	9L7
5-6	-	-	-	Not Occupied	-	-
7	0	RD/YE	2340	Battery Positive Voltage (15 amp)	I	-
8	0	VT/YE	43	Accessory Voltage (10 amp)	II	-
9	0	GN	5060	Low Speed GMLAN Serial Data	II	-
10	0	BK	1050	Ground	I	-
11	0	VT/WH	1939	Run/Crank Ignition 1 Voltage (15 amp)	I	-
12-13	-	-	-	Not Occupied	-	-
14	0		966	Upfitter Provision (30amp) Aux Switch 2 Output	I	9L7
15-16	-	-	-	Not Occupied	-	-
17	0	RD/YE	2340	Battery Positive Voltage (15 amp)	I	-
18	-	-	-	Not Occupied	-	-
19	0	GN/GY	817	Vehicle Speed Signal (4k PPM)	II	-
20	0		965	Upfitter Provision (30amp) Aux Switch 1 Output	I	9L7

Note: The **yellow** shaded terminals are available signals for Upfitter usage.

General Motors Upfitter Integration

<http://www.gmupfitter.com> • 1-800-875-4742 (Upfitter Hotline)

Under fuse Block Label

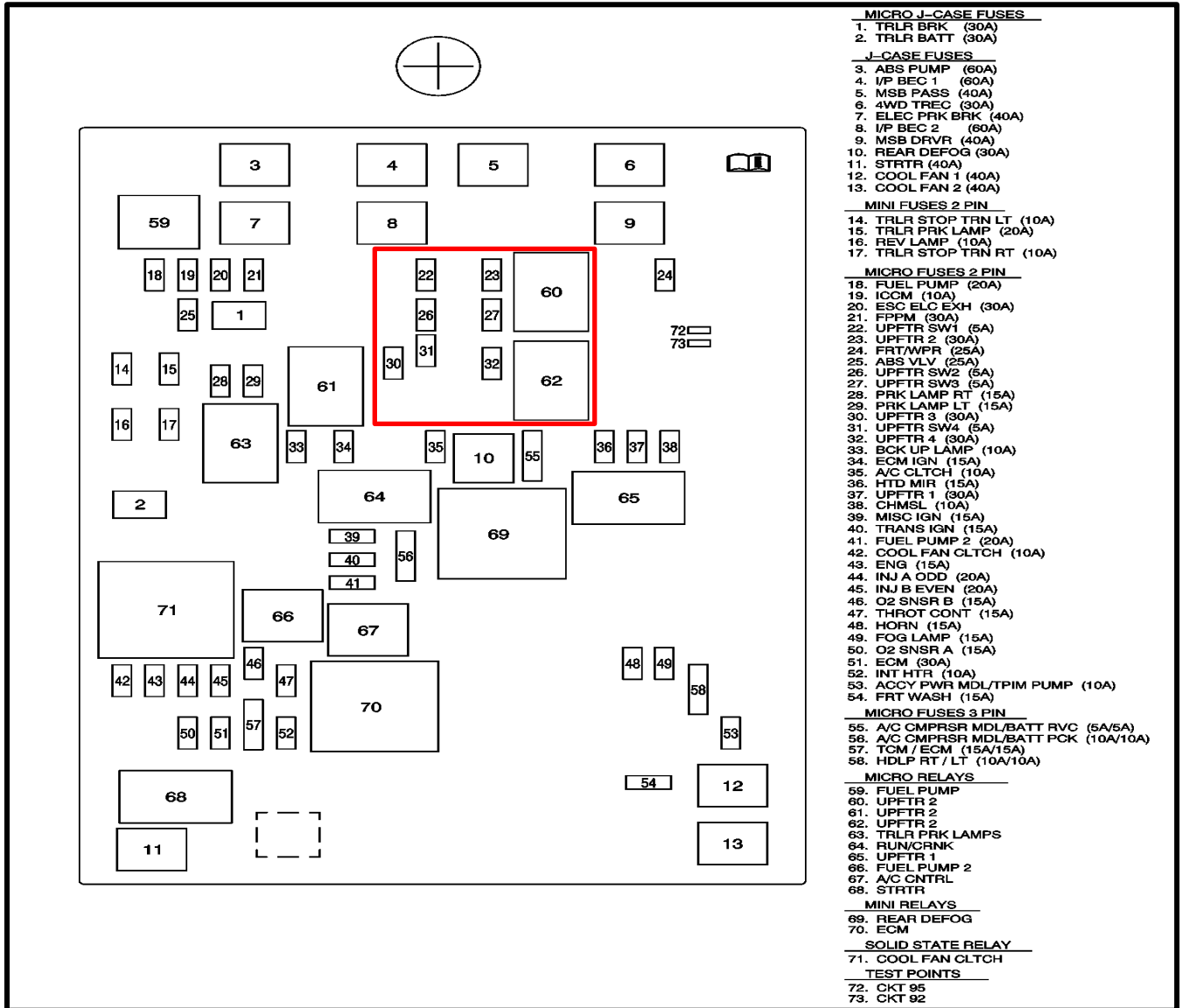

Figure 5

NOTE: The red squared area in Figure 5 reflects the fuses involved in the possible fuse reconfiguration used for the powering of the AUX switches.

Aux Switch Powering/Fuse Configurations



CAUTION:

Never populate both fuse locations for either pairing of AUX switches. This is to mean do NOT install fuses in both locations of 22 and 26 or in both locations of 27 and 31.

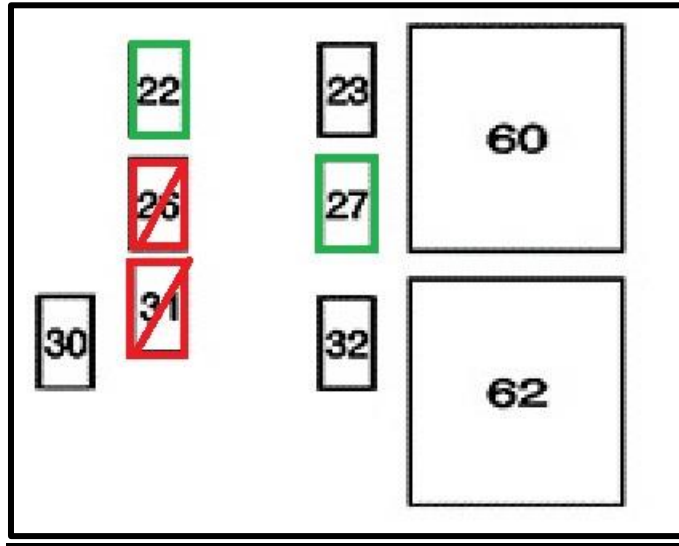

Figure 6

Figure 6 shows the fuses configured for all switches (1, 2, 3 & 4) for battery powered. This is the default fuse location from vehicle manufacturing (note fuse locations 26 & 31 are unpopulated).



CAUTION:

Never populate both fuse locations for either pairing of AUX switches. This is to mean do NOT install fuses in both locations of 22 and 26 or in both locations of 27 and 31.

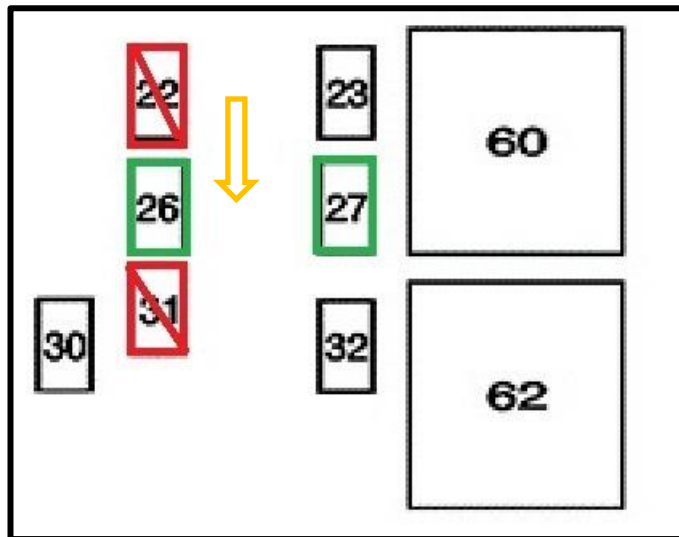



Figure 7

Figure 7 shows the fuses configured for switches 1 & 2 to be Ignition powered and switches 3 & 4 being battery powered. This configuration is accomplished by **MOVING** the fuse from location 22 **TO** location 26 (leaving locations 22 & 31 unpopulated)

General Motors Upfitter Integration

<http://www.gmupfitter.com> • 1-800-875-4742 (Upfitter Hotline)

 **CAUTION:**

Never populate both fuse locations for either pairing of AUX switches. This is to mean do NOT install fuses in both locations of 22 and 26 or in both locations of 27 and 31.

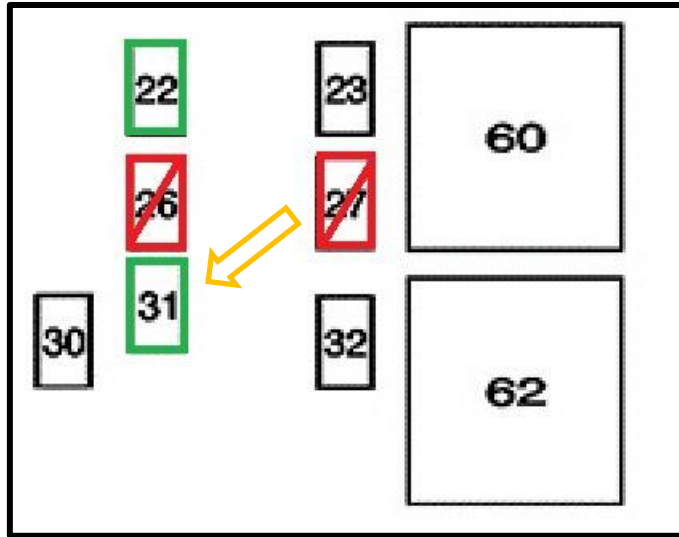



Figure 8

Figure 8 shows the fuses configured for switches 1 & 2 to be Battery powered and switches 3 & 4 being Ignition powered. This configuration is accomplished by **MOVING** the fuse from location 27 **TO** location 31 (leaving locations 26 & 27 unpopulated)

 **CAUTION:**

Never populate both fuse locations for either pairing of AUX switches. This is to mean do NOT install fuses in both locations of 22 and 26 or in both locations of 27 and 31.

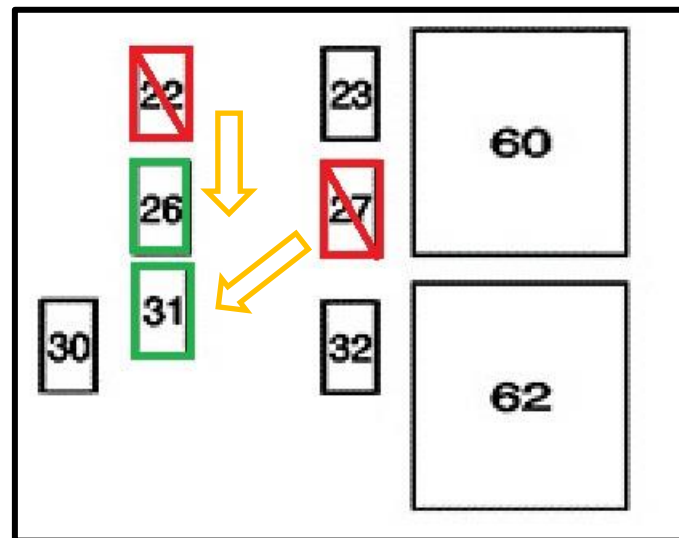

Figure 9

Figure 9 shows the fuses configured for all switches (1, 2, 3 & 4) to be Ignition powered. This configuration is accomplished by **MOVING** the fuse from location 22 **TO** location 26 and **MOVING** 27 **TO** 31 (leaving fuse locations 22 and 27 unpopulated)

General Motors Upfitter Integration

<http://www.gmupfitter.com> • 1-800-875-4742 (Upfitter Hotline)

Wire Harness Pass-thru location

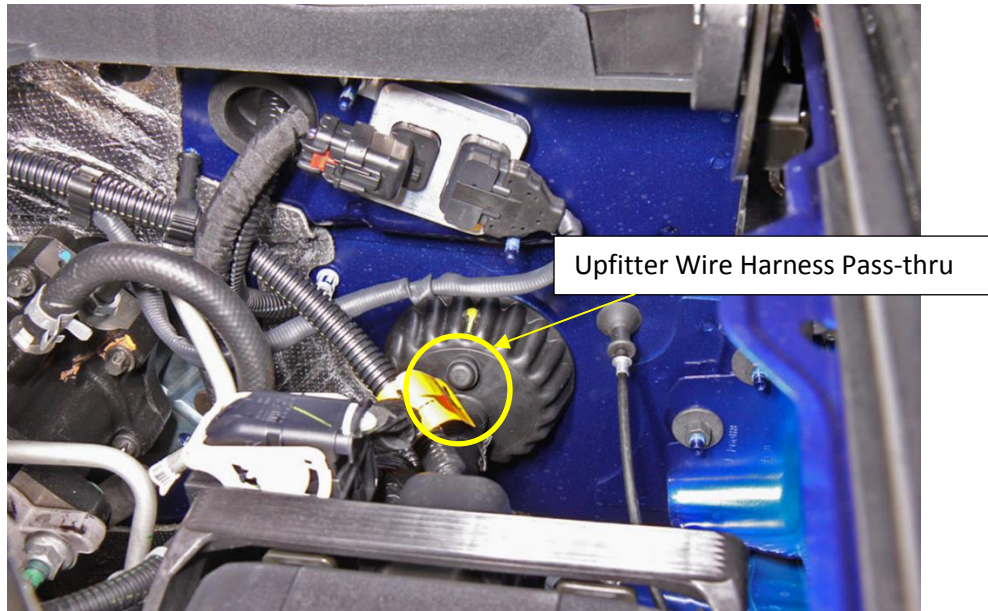

Figure 10

Figure 10 shows the location of the upfitter wire harness pass through

Wiring Schematic

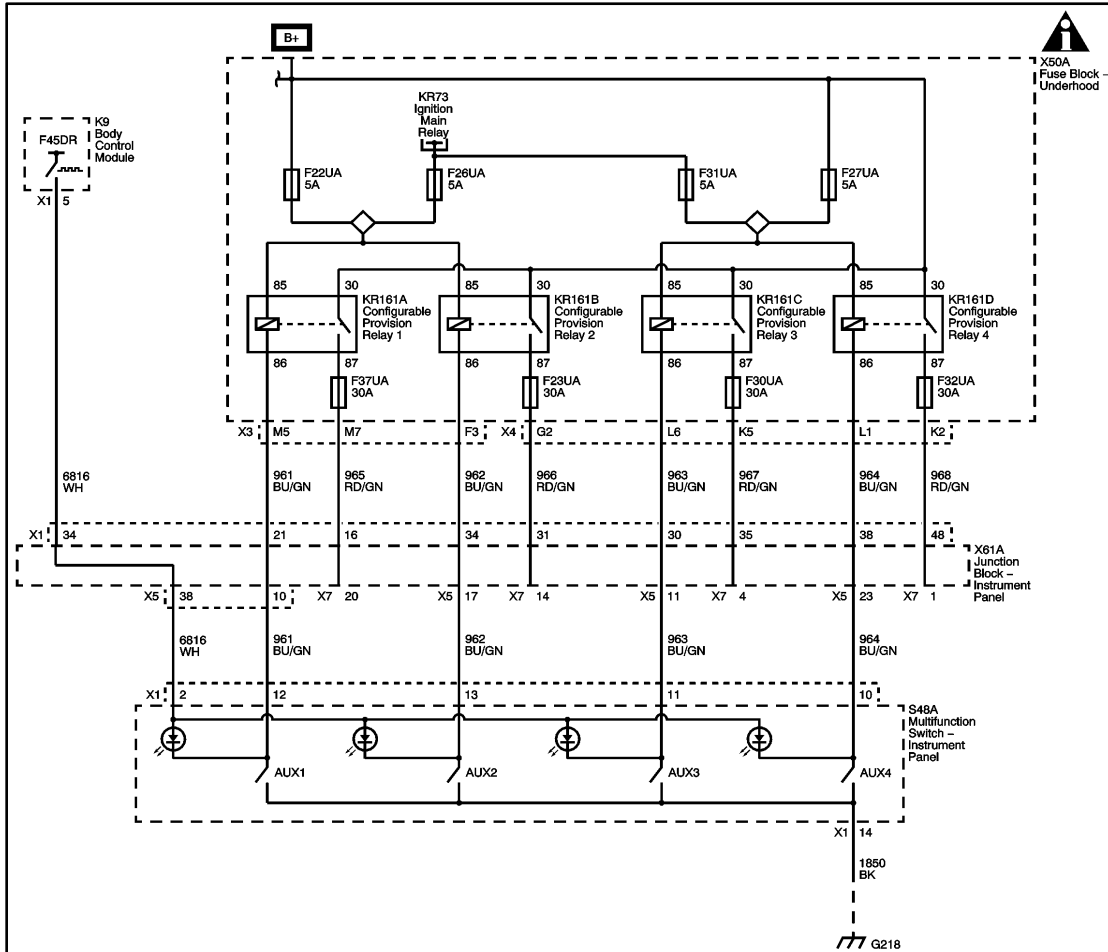

Figure 11

General Motors Upfitter Integration

<http://www.gmupfitter.com> • 1-800-875-4742 (Upfitter Hotline)