

# Abnormal Metallic Knock Noise from Front of Vehicle

**Service Category** Drivetrain

**Section** Hybrid Transmission/Transaxle

**Market** USA

Toyota Supports  
 ASE Certification 

## Applicability

YEAR(S)	MODEL(S)	ADDITIONAL INFORMATION
2004 – 2008	Prius	Plant Code(s): 3, 7 WMI(s): JTD

## Introduction

Some customers with 2004 – 2008 model year Prius vehicles may report a metallic knock or clunk noise from the engine bay heard only while driving over speed bumps or rough road conditions. The engine mount assembly has been improved to prevent this condition. Follow the repair procedure below to address customer concerns.

### NOTE

The affected mount is attached to the hybrid transaxle. The part name in this service bulletin is "Insulator, Engine Mounting, LH" (left-hand). The Repair Manual also refers to this part as "Engine Mounting Bracket No. 3".

## Production Change Information

This TSB applies to vehicles produced **BEFORE** the Production Change Effective VINs shown below.

MODEL	PLANT	PRODUCTION CHANGE EFFECTIVE VIN*
Prius	Tsutsumi	JTDKB2#U# <u>83</u> 430579
	Toyota Auto Body	JTDKB2#U# <u>87</u> 793270

\* Underlined number in VIN (11th digit) represents assembly plant line code.

## Abnormal Metallic Knock Noise from Front of Vehicle

### Warranty Information

OP CODE	DESCRIPTION	TIME	OFP	T1	T2
EG8040	R & R Engine Mounting Insulator LH	2.1	12306-21030	91	57

#### APPLICABLE WARRANTY

- This repair is covered under the Toyota Powertrain Warranty. This warranty is in effect for 60 months or 60,000 miles, whichever occurs first, from the vehicle's in-service date.
- Warranty application is limited to correction of a problem based upon a customer's specific complaint.

### Parts Information

PREVIOUS PART NUMBER	CURRENT PART NUMBER	PART NAME	QTY
N/A	12372-21111	Insulator, Engine Mounting, LH	1
00272-SLLC2	Same	Super Long Life Coolant (SLLC)	As Needed

### Required Tools & Equipment

REQUIRED SST'S	PART NUMBER	QTY
Safety Gloves*	<a href="#">00002-03100-S</a> (Small)	1
	<a href="#">00002-03200-M</a> (Medium)	
	<a href="#">00002-03300-L</a> (Large)	

\* Essential SST.

#### NOTE

Additional SSTs may be ordered by calling SPX/OTC at 1-800-933-8335.

## Abnormal Metallic Knock Noise from Front of Vehicle

### Repair Procedure

After verifying that the "knock" noise is coming from the area near the hybrid transaxle, replace the engine mounting insulator LH with a NEW part.

1. Remove the inverter w/converter assembly.

**NOTE**

**Do NOT** replace the inverter.

Refer to the Technical Information System (TIS), applicable model year Prius Repair Manual:

- [2004](#) / [2005](#) Prius:  
*Engine/Hybrid System – Hybrid/Battery Control System – “W/converter Inverter Assy: Replacement”*
- [2006](#) / [2007](#) / [2008](#) Prius:  
*Engine/Hybrid System – Hybrid/Battery Control System – “P112 Hybrid Vehicle Control: Inverter With Converter: Removal”*

2. Support the hybrid transaxle assembly by using a transmission jack.
3. Remove and replace the engine mounting insulator LH.
  - A. Remove the engine mounting insulator sub-assembly LH from the vehicle.

**Figure 1.**

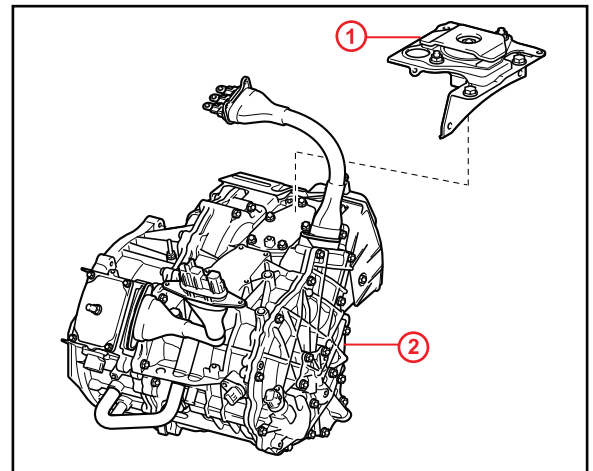

<b>1</b>	<b>No. 3 Engine Mounting Bracket</b>
<b>2</b>	<b>Hybrid Vehicle Transaxle Assembly</b>

## Abnormal Metallic Knock Noise from Front of Vehicle

### Repair Procedure (Continued)

- B. Remove two nuts from engine mounting insulator sub-assembly LH.

Figure 2. Engine Mounting Insulator Sub-Assembly (LH)

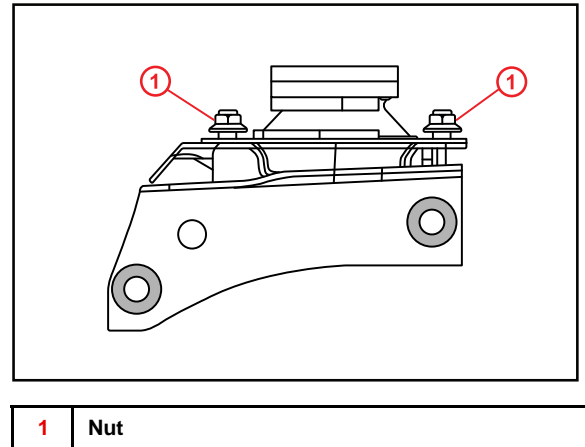

- C. Replace the engine mounting insulator LH with the NEW part (P/N 12372-21111).

Figure 3.

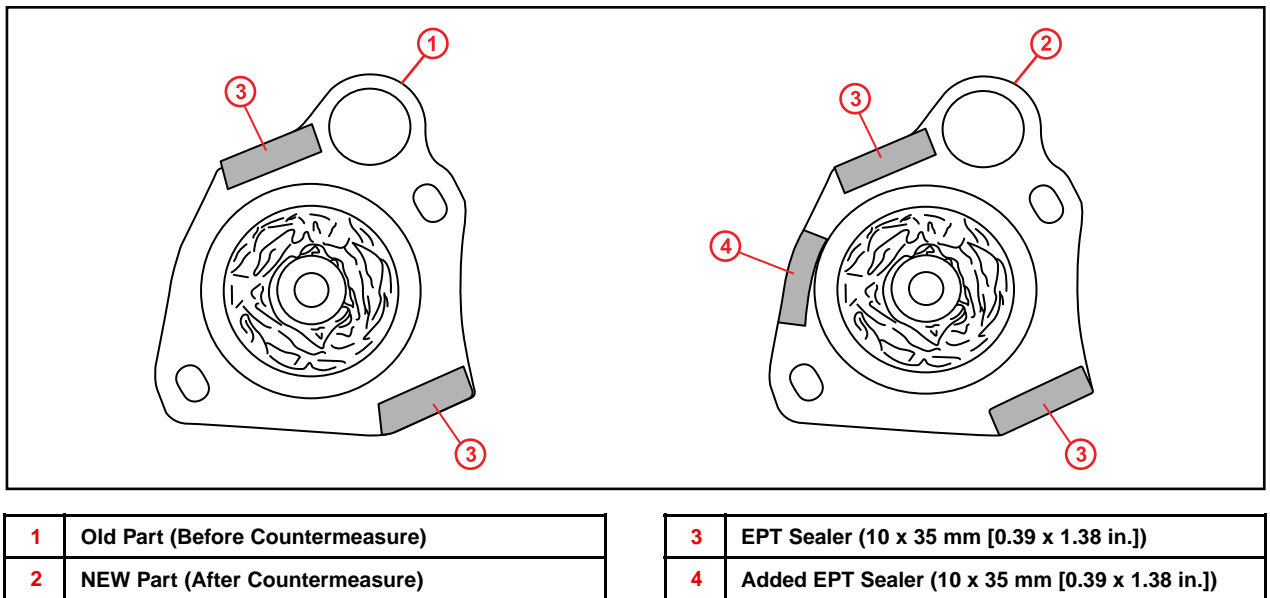

- D. Tighten the 2 nuts.  
**Torque: 64 N\*m (640 kgf\*cm, 47 ft\*lbf)**
- E. Attach the engine mounting insulator sub-assembly LH on the vehicle.  
**Torque: 80 N\*m (800 kgf\*cm, 59 ft\*lbf)**

## Abnormal Metallic Knock Noise from Front of Vehicle

---

### Repair Procedure (Continued)

4. Install the inverter w/converter assembly.

Refer to TIS, applicable model year Prius Repair Manual:

- [2004](#) / [2005](#) Prius:  
*Engine/Hybrid System – Hybrid/Battery Control System – “W/converter Inverter Assy: Replacement”*
- [2006](#) / [2007](#) / [2008](#) Prius:  
*Engine/Hybrid System – Hybrid/Battery Control System – “P112 Hybrid Vehicle Control: Inverter With Converter: Installation”*

5. Road test to verify proper operation of the vehicle.