

© 2015 Mazda Motor of America, Inc.

Subject: RATTLE NOISE FROM FRONT DOOR GLASS	Bulletin No: 09-016/15
	Last Issued: 05/18/2015

BULLETIN NOTE

- This bulletin supersedes the previous bulletins 09-017/14 issued 08/29/14, 03/05/14 and 08/18/14 and 09-011/13 issued 04/17/13. The APPLICABLE MODEL(S)/VINS, DESCRIPTION, REPAIR PROCEDURE, PART(S) and WARRANTY INFORMATION have been revised.
- Changes are noted below in Red beside the change bar.

APPLICABLE MODEL(S)/VINS

2013-2016 CX-5

2014-2016 Mazda6

2014-2016 Mazda3

DESCRIPTION

Some vehicles may experience a rattle noise from the front door glass when driving with the window open approx. 1/2 to 4 inches (1 - 10 cm).

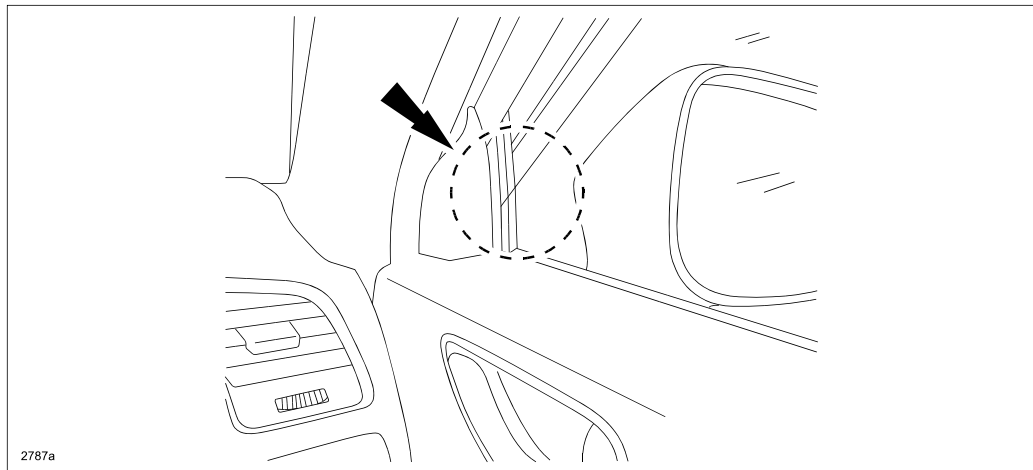

The rattle noise may be caused by insufficient holding force of the glass run channel. To increase the holding force, the shape of glass run channel has been changed and non-woven pads have been attached to the glass run channel.

Customers having this concern should have their vehicle repaired using the following repair procedure.

REPAIR PROCEDURE

1. Verify the customer concern. The rattle noise should go away when holding the slightly opened window by hand or when the window is completely closed.
 - If the noise goes away, proceed to the next step to attach non-woven pads to Positions (A), (B) and (C) of the glass run channel (G) as shown.

NOTE: Depending on vehicle types (production change levels), non-woven pads or resin foam have already been attached to Position C or Positions A and C. In this case, it is not necessary to attach additional non-woven pads to these position(s).

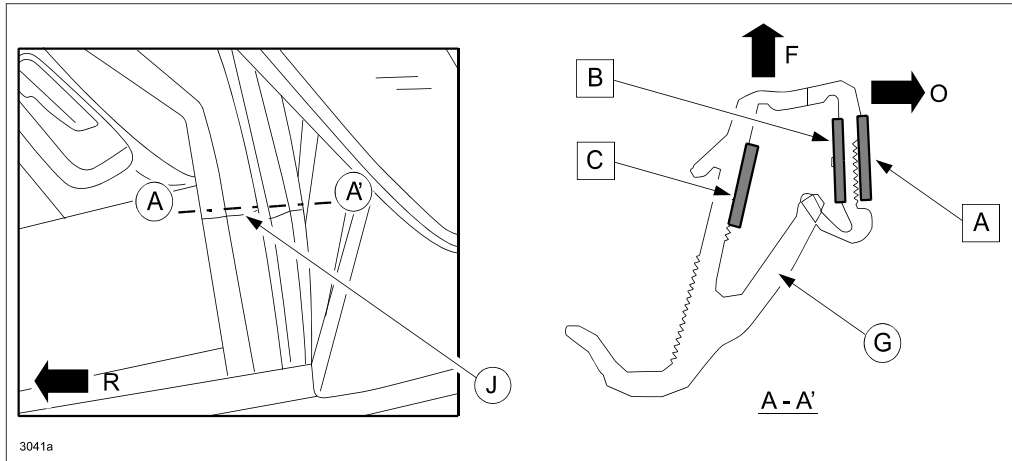

F = Front
R=Rear
O=Outer
J=Molded Jointed Line

- If the noise does not go away, this service bulletin does not apply. Troubleshoot the noise according to section 09 (Body and Accessories) of the MS3 online instructions or the Workshop Manual.

2. Cut non-woven pads to size for position(s) according to vehicle type listed below (mass production change level).
 - a. Obtain the 0.25 mm thick pad from the Noise Parts Set.
 - b. Using a straight-edge and sharp knife, cut the pad into the sizes necessary for the vehicle repair, then stack the 4 pieces on top of one another to create a pad 1 mm thick.

CX-5

Vehicle Type	Production Date Range	VIN Range		Position and size (T x W x L mm)		
				Position A	Position B	Position C
A	Job#1 - 1/28/2012	JM3KE*****	100001 to 300112	A(1x7x100)	A(1x7x40)	A(1x7x60)
B	1/28/2012 - TBD		300113 to 999999	A(1x7x40)	A(1x7x40)	X

Mazda3

Vehicle Type	Production Date Range	VIN Range		Position and size (T x W x L mm)		
				Position A	Position B	Position C
B	Job#1 - 7/1/2014	JM3BM***** (Japan built)	100001 to 218352	A(1x7x50)	A(1x7x40)	X
C	7/2/2014 - TBD		218353 to 999999	X	A(1x7x40)	X
B	Job#1 - 6/2/2014	3MZBM***** (Mexico built)	100001 to 117653	A(1x7x50)	A(1x7x40)	X
C	6/3/2014 - TBD		117654 to 999999	X	A(1x7x40)	X

Mazda6

Vehicle Type	Production Date Range	VIN Range		Position and size (T x W x L mm)		
				Position A	Position B	Position C
C	Job#1 - TBD	JM1GJ*****	100001 to 999999	X	A(1x7x40)	X

A: Attach the specified size of non-woven pad.

X: A non-woven pad or a resin foam has already been attached to this position so it is not necessary to attach.

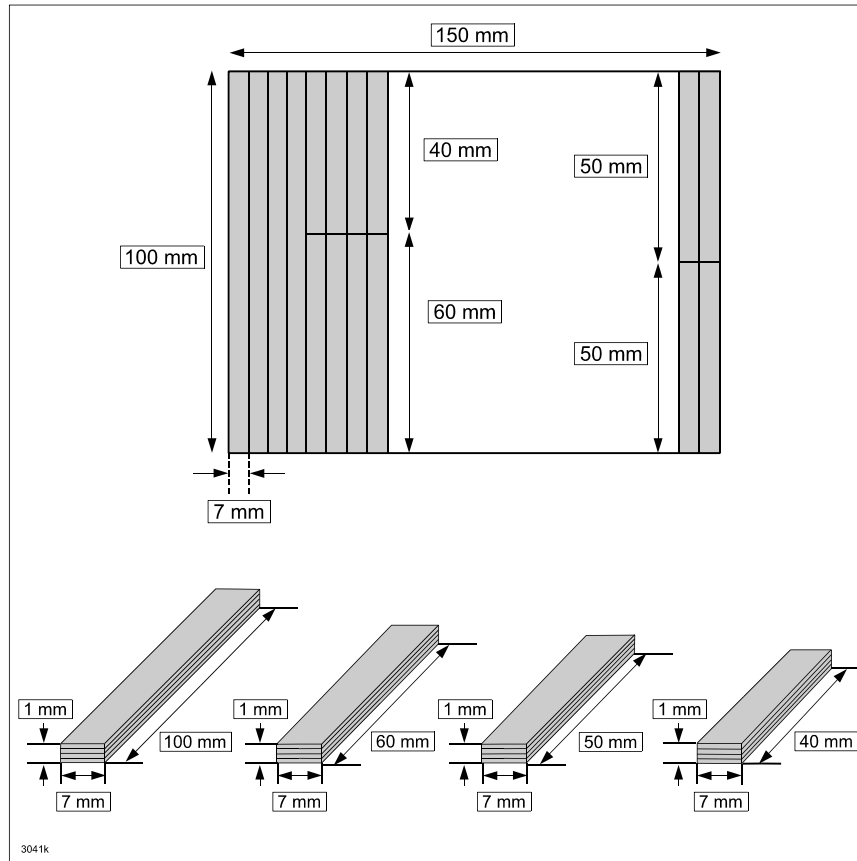

3. Open the door glass fully and pull the glass run channel off of the door frame (right side glass run channel shown below).

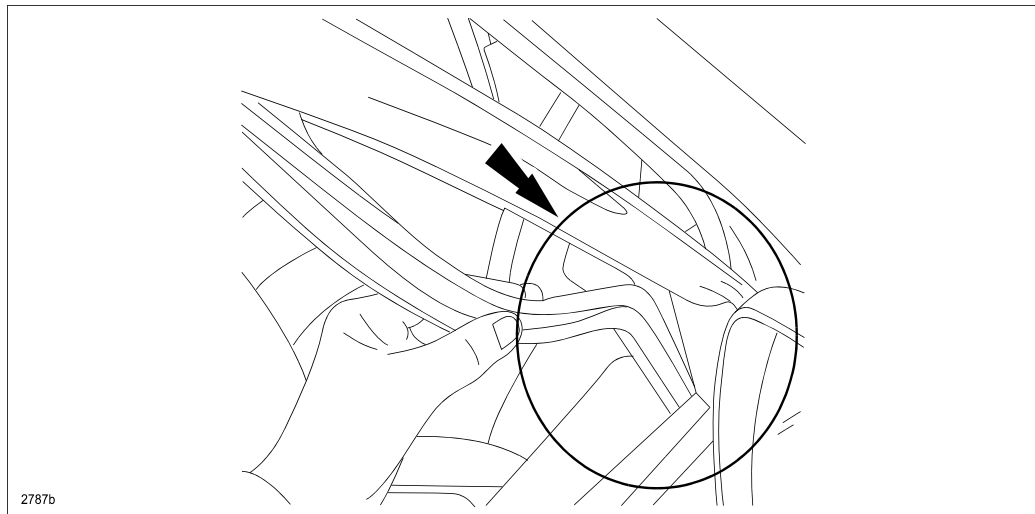

4. Degrease the glass run channel where the pads will be attached to the glass run channel - Positions (A), (B) and (C).

NOTE: Depending on the vehicle type, degreasing is not necessary for Position C or Positions C and A if a non-woven pad or a resin foam has already been attached there.

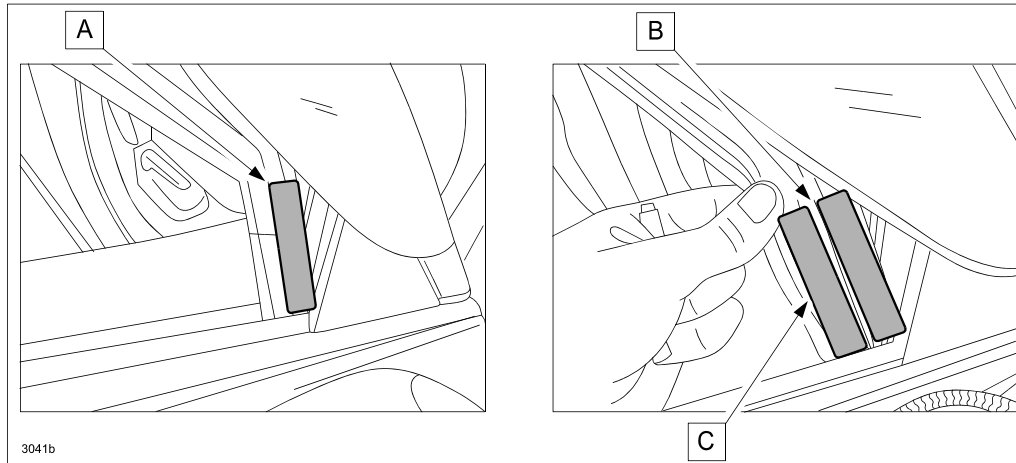

NOTE: The picture is a perspective view only. In the actual work, attach the pad by flipping the outer lip. Refer to picture in step 1.

5. Apply an adhesion promoter (one that is suitable for use on plastic) to the locations where the pads will be attached.

NOTE:

- Obtain adhesion promoter locally.
- Recommended adhesion promoter: 3M K-540NT, K500 or 4298UV. If these products cannot be obtained, any adhesion promoter suitable for plastic can be used.

6. According to the vehicle type, attach the non-woven pads to the glass run channel as shown below.
 a. Position A

Vehicle Type	Pad Size (mm)	Attach pad along the uneven line of the lip.
CX-5 Type A	1x7x100	
CX-5 Type B	1x7x40	
Mazda3 Type B	1x7x50	
F=Front O=Outer	G=Glass run channel (RH) J=Jointed line	

For CX-5 Type A
 Attach pad of 100mm length (A)
 40 mm above the jointed line (J).

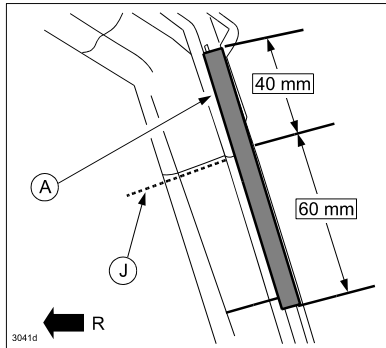

R=Rear

For CX-5 Type B
 Attach pad of 40mm length (A)
 above the jointed line (J).

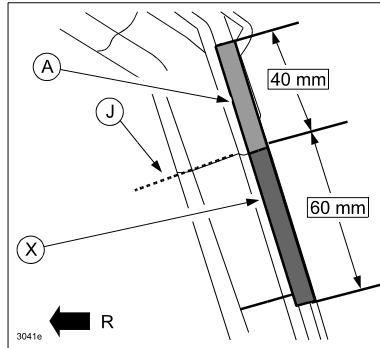

X: This pad has already been attached to this portion.

For Mazda3 Type B
 Attach pad of 50mm length (A)
 below the jointed line (J).

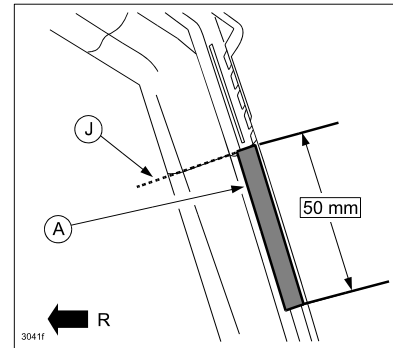

b. Position B

Vehicle Type	CX-5 All	Mazda3 All	Mazda6 All
Pad Size (mm)	1x7x40	1x7x40	1x7x40

Attach the pad along the uneven line of the back side of the lip (A).
 F=Front; O=Outer

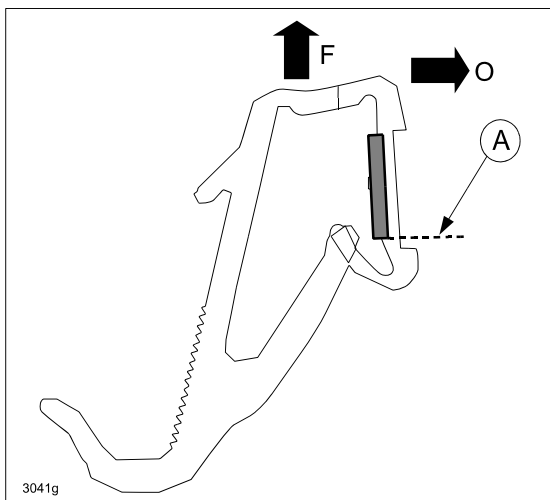

For All Vehicle Types
 Attach pad of 40mm length (A) right above the molded joint line (J).

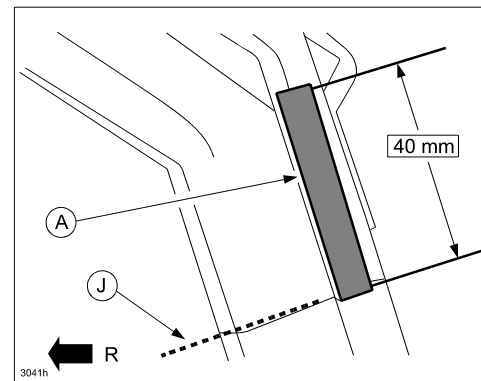

Note: The picture is a perspective view only. In the actual work, attach the pad by flipping the outer lip.

c. Position C

Vehicle Type	Pad Size (mm)
CX-5 Type A	1x7x60

Attach pad positioning it 3mm away (A) from the back of lip.
 F=Front; O=Outer

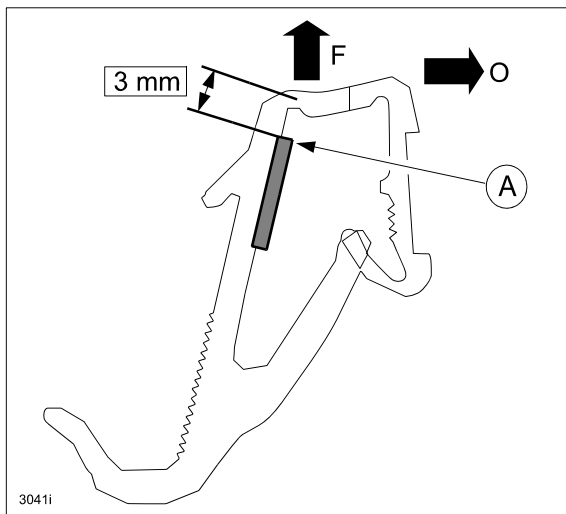

For CX-5 Type A

Attach pad (A) of 60mm length right below jointed line (J).

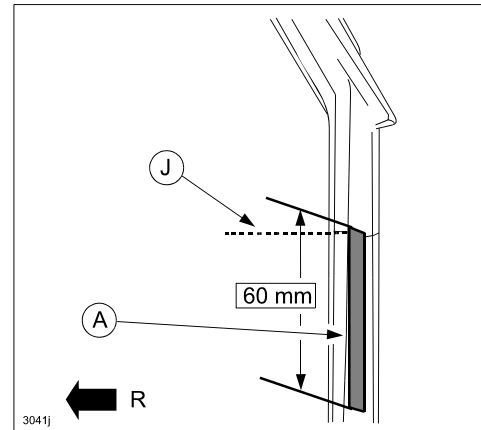

Note: The picture is a perspective view only. In the actual work, attach the pad by flipping the outer lip.

7. Reinstall the glass run channel back to the original position.
8. Operate the door glass up and down to verify proper operation.
9. Repeat the repair on the glass run channel on the other side if necessary.

PART(S) INFORMATION

Part Number	Description	Qty.	Notes
TA01-76-100	Noise Parts Set	1	Use non-woven of 0.25 mm thickness. (One pad can repair 2 to 40 vehicles, depending on the vehicle type)

WARRANTY INFORMATION

NOTE:

- This warranty information applies only to verified customer complaints on vehicles eligible for warranty repair.
- This repair will be covered under Mazda's New Vehicle Limited Warranty term.
- Additional diagnostic time cannot be claimed for this repair.

Warranty Type	A	
Symptom Code	82	
Damage Code	97	
Part Number Main Cause	****-59-605*/****-58-605* (check EPC for the part number of the glass run channel applicable to the VIN in repair)	
Quantity	0	
Operation Number / Labor Hours	Attach pad to Position B only	XXL41XRX / 0.2 Hrs. (one side) XXL42XRX / 0.3 Hrs. (both sides)
	Attach pad to Positions A and B, or Attach pad to Positions A, B, and C	XXJ5CXRX / 0.3 Hrs. (one side) XXJ5DXRX / 0.4 Hrs. (both sides)

NOTE: Do not claim the noise parts set (P/N TA01-76-100) as a related part. The amount of pad and adhesion promotor used for this repair is included in the labor allowance.