

Spider Bearing Cam Seal Vent Instructions

SB-10057444-2261

SAF® Series Drum Brake Axles

Introduction

These instructions provide the necessary information to properly vent the inner cam seal on the SAF® drum brake axle. Read and understand all of the procedures presented in these instructions before starting work on any SAF® drum brake axle.

We recommend only the use of SAF-HOLLAND® Original Parts.

NOTE: A list of SAF-HOLLAND® technical support locations that supply SAF-HOLLAND® Original Parts can be found on our website at www.safholland.us or contact our customer service group at 888-396-6501.

Notes, Cautions, and Warnings

These instructions, contain the terms "NOTE", "IMPORTANT", "CAUTION", and "WARNING", followed by useful product information. The terms are defined as follows:

NOTE: Includes additional information to enable accurate and easy performance of procedures.

IMPORTANT: Includes additional information that if NOT followed could lead to hindered product performance.

CAUTION

Used without the safety alert symbol, indicates a potentially hazardous situation which, if not avoided, could result in property damage.

⚠ CAUTION

Indicates a potentially hazardous situation which, if not avoided, could result in minor or moderate injury.

⚠ WARNING

Indicates a potentially hazardous situation which, if not avoided, could result in death or serious injury.

1. General Safety Instructions

- Read and observe all Warning and Caution hazard alert messages in this publication. The alerts provide information that can help prevent serious personal injury, damage to components, or both.

⚠ WARNING

Failure to follow all the repair procedures contained in these instructions could cause a hazardous condition to develop which, if not avoided, could result in death or serious injury.

- All SAF® drum brake axle repair and maintenance **MUST** be performed by a trained technician using proper tools and safe procedures.

NOTE: In the United States, workshop safety requirements are defined by federal and/or state Occupational Safety and Health Act. Equivalent laws may exist in other countries. These instructions are written based on the assumption that OSHA or other applicable employee safety regulations are followed by the location where work is performed.

Venting Instructions

These instructions are for the proper venting of the inner cam bearing seals located at the spider on your SAF® drum brake axle. Additional information can also be found in the drum brake axle service manual document number XL-TA100060M-en-US.

Before Starting any axle brake service procedures, park the trailer on a level surface. Exhaust the air from the suspension(s), chock the wheels to prevent the trailer from moving and support the trailer and axles(s) with safety stands.

WARNING Failure to properly secure the trailer prior to commencing work could create a crush hazard which, if not avoided, could result in death or serious injury.

In the case that the bearing located inside of the axle's spider is over lubricated, it is possible that a high pressure condition could exist which will require venting.

1. Locate the inner cam seals on your axle's spiders.
2. On each side of the axle, vent the zerk fitting on the cam bearing to relieve any pressure if it exists.
3. Remove the snap rings and washers from the S-cam end of the cam shafts. Push them inward on the cam towards the brake or slack adjusters to gain access to the inner seal.
4. Inspect the inner seals for orientation on each axle. If the rubber wiper of the seal is visible (**Figure 1**) or previous version (**Figure 2**) with visible vent holes, no additional action is required and the washer and snap ring can be re-installed, proceed to Step 9
5. If the steel shoulder is visible (**Figure 3**), it will be necessary to vent the seal.

Figure 1

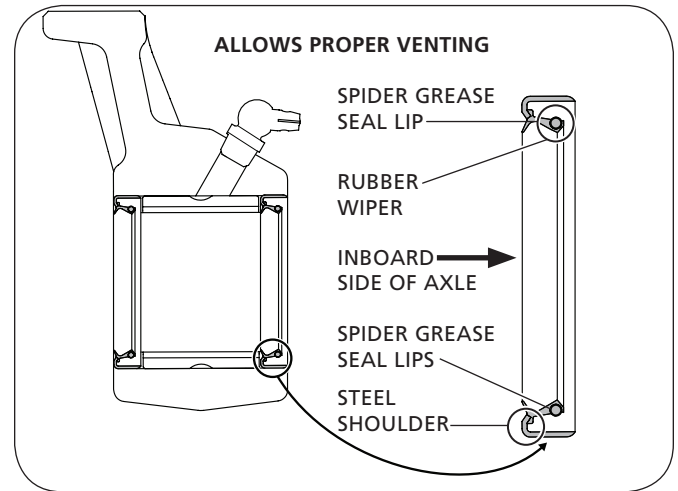

Figure 2

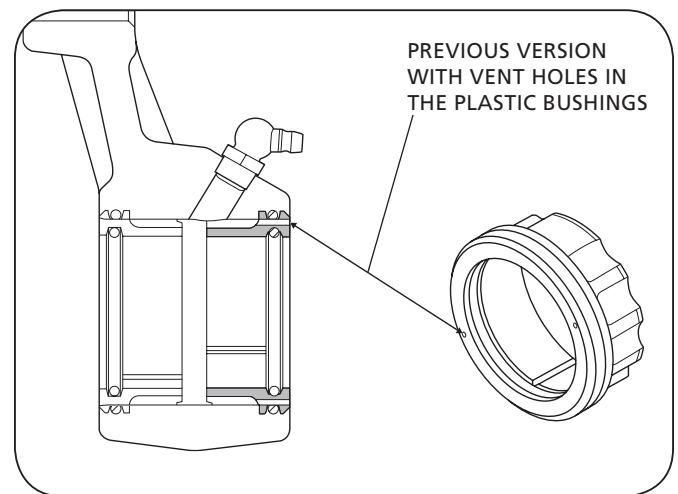
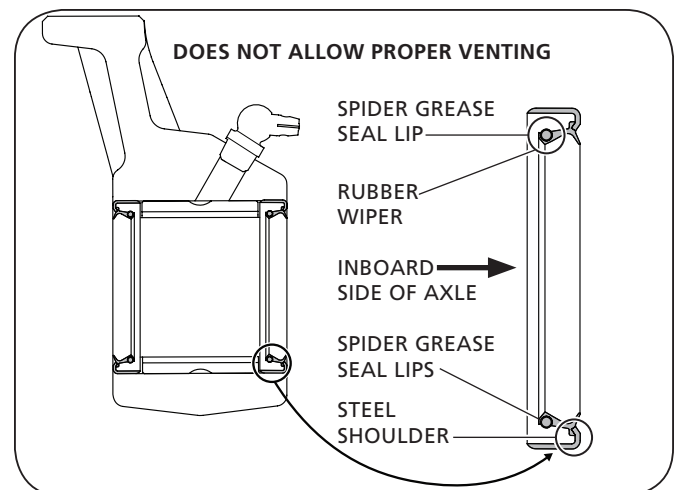

Figure 3



6. Using an awl with a diameter of approximately 1/8", locate the tip in between the bearing spider and the steel shoulder of the cam seal at approximately a 45° angle (**Figure 4**).
7. Using a hammer, tap the awl lightly two (2) or three (3) times or until the steel shoulder of the seal has been vented (**Figure 4**). Once the inner cam seal is vented, grease should be visible from the newly created vent hole.
8. Replace the washer and snap ring and repeat this process for the other inner seal of this axle and for all other axles which are installed on the unit.
9. When the procedures are complete, verify proper brake operation prior to returning it to service in accordance with XL-TA100060M-en-US.

⚠ WARNING Failure to verify proper brake operation prior to returning it to service could affect brake performance or render them inoperable which, if not avoided, could result in death or serious injury.

Figure 4

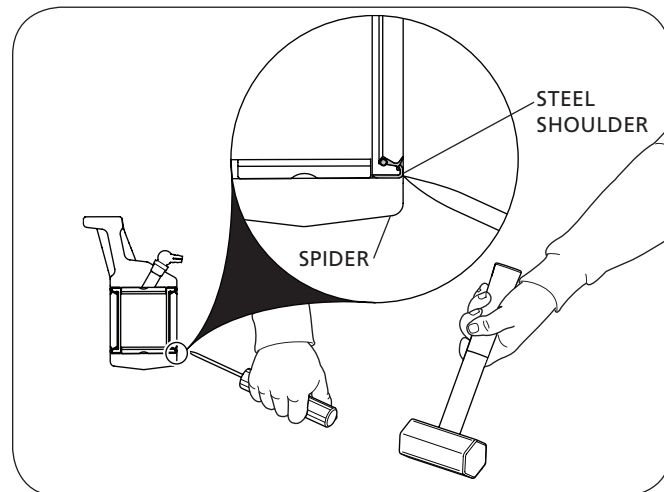



From fifth wheel rebuild kits to suspension bushing repair kits, SAF-HOLLAND Original Parts are the same quality components used in the original component assembly.

SAF-HOLLAND Original Parts are tested and designed to provide maximum performance and durability. Will-fits, look-alikes or, worse yet, counterfeit parts will only limit the performance potential and could possibly void SAF-HOLLAND's warranty. Always be sure to spec SAF-HOLLAND Original Parts when servicing your SAF-HOLLAND product.

SAF-HOLLAND USA • 888.396.6501 • Fax 800.356.3929
www.safholland.us

SAF-HOLLAND CANADA • 519.537.3494 • Fax 800.565.7753
WESTERN CANADA • 604.574.7491 • Fax 604.574.0244
www.safholland.ca

SAF-HOLLAND MEXICO • 52.55.5362.8743 • Fax 52.55.5362.8743
www.safholland.com.mx

info@safholland.com