



# TECHNICAL SERVICE BULLETIN

## MT88 Manual Transmission - No 3rd Gear And/Or Grinding Noise Going Into 3rd And/Or 4th Gear

**23-2409**

08 December  
2023

This bulletin supersedes 23-2219. Reason for update: Incorrect or Missing Parts

### Model:

Ford 2021-2023 Bronco	Transmission: MT88 Manual Transmission
--------------------------	--

### Summary

This article supersedes TSB 23-2219 to update the Parts List.

**Issue:** Some 2021-2023 Bronco vehicles may exhibit no 3rd gear engagement and/or a grinding noise going into 3rd and/or 4th gear. This may be due to the transmission shifting system and clutch interaction such as a lack of full clutch disengagement during shifts and/or placing weight upon the gear shift lever while driving. To correct the condition, follow the Service Procedure to replace the 3rd and/or 4th gears and/or synchronizers as needed.

**Action:** Follow the Service Procedure to correct the condition if the vehicle meets the following criteria:

- 2021-2023 Bronco
- Equipped with MT88 manual transmission
- At least one of the following:
  - Grinding noise going into 3rd and/or 4th gear
  - Will not go into 3rd gear

### Parts

Service Part Number	Quantity	Description	Unit of Issue	Piece Quantity	Note
MU7Z-7M157-A	1	Synchronizer Ring Plate	1	1	
MU7Z-7101-A	1	3rd Gear And Cone Assembly	1	1	
MU7Z-7107-B	2	Synchronizer Ring	1	1	
MU7Z-7W441-A	1	Gear Shift Lever Pin	1	1	
MU7Z-7048-A	1	Input Shaft Seal	1	1	
BR3Z-7052-A	1	Rear Oil Seal	1	1	
JB3Z-4B496-B	6	Front Driveshaft Bolts And Retaining Straps	1	6	
LB3Z-4B496-A	8	Rear Driveshaft Bolts And Retaining Straps	1	8	
MU7Z- 7124-C	1	Synchronizer Hub	1	1	
W710624-S300	1	Roll Pin Reverse/Crawl Shift Fork	1	1	
W500121-S439	4	Transfer Case Bolts	4	1	
W520103-S442	4	Exhaust Flange Nut	4	1	
MB3Z-9450-B	1	Exhaust Manifold Gasket	1	1	

MU7Z-7P497-A	1	Counter Shaft Bore Plug	1	1	This may be called Compression Ring
BR3Z-7064-A	1	Input Shaft Snap-Ring	1	1	
MU7Z-3K050-B	2	6th Gear Snap-Ring	1	2	
MU7Z-3K050-A	2	Reverse/Crawl Gear Snap-Ring	1	1	
MU7Z-3K050-C	1	4th Gear Snap-Ring	1	1	
ZC-20	As Needed	Motorcraft® Engine Shampoo and Degreaser	1	As Needed	
TA-357	As Needed	Motorcraft® High Performance Engine RTV Silicone	1	As Needed	
XT-11-QDC	As Needed	Dual Clutch Transmission Fluid	1	As Needed	
PM-4-A	As Needed	Motorcraft® Metal Brake Parts Cleaner	1	As Needed	
ZC-31-B	As Needed	Motorcraft® Metal Surface Prep Wipes	1	As Needed	
PM-20	As Needed	Motorcraft® DOT 4 LV High Performance Motor Vehicle Brake Fluid	1	As Needed	
ZC-30-A	As Needed	Motorcraft® Silicone Gasket Remover	1	1	

Quantity refers to the amount of the service part number required to repair the vehicle.

Unit of Issue refers to the number of individual pieces included in a service part number package.

Piece Quantity refers to the total number of individual pieces required to repair the vehicle.

As Needed indicates the amount of the part may vary and/or is not a whole number. Parts can be billed out as non-whole numbers, including less than 1.

If Needed indicates the part is not mandatory.

#### Parts - Parts To Inspect And Replace Only If Necessary

Service Part Number	Quantity	Description	Unit of Issue	Piece Quantity
MU7Z- 7230-A	If Needed	Shift Fork 3rd and 4th Gears	1	1

**Warranty Status:** Eligible under provisions of New Vehicle Limited Warranty (NVLW)/Service Part Warranty (SPW)/Special Service Part (SSP)/Extended Service Plan (ESP) coverage. Limits/policies/prior approvals are not altered by a TSB. NVLW/SPW/SSP/ESP coverage limits are determined by the identified causal part and verified using the OASIS part coverage tool.

#### Labor Times

Description	Operation No.	Time
2021-2023 Bronco MT88 Transmission: Replace Synchronizer Assemblies for 3rd And 4th Gear And The 4th Gear Synchronizer Ring (Can Be Used With Operation B And Or MT) (Do Not Use With Any Operations Outside Of This Article)	232409A	9.2 Hrs.
Additional Time For Vehicles With Electronic Sway Bar Disconnect (Can Be Used With Operation A)	232409B	0.8 Hrs.
Additional Time To Replace Any Additional Parts Discovered During Inspection (Can Be Used With Operation A)	MT232409	Actual Time

#### Repair/Claim Coding

Causal Part:	7107
Condition Code:	13

## Service Procedure

1. Remove the transmission from the vehicle. Refer to Workshop Manual (WSM), Section 308-03.
2. Disassemble the transmission. Refer to WSM, Section 308-03 > Disassembly > Transmission, Steps 1-34.
3. Remove the output shaft from the transmission case to gain access to the 3rd and 4th gears and synchronizer assemblies. Refer to WSM, Section 308-03 > Disassembly and Assembly of Subassemblies > Input Shaft, Steps 1-5.
4. Replace the following components and any associated damaged parts. Refer to WSM, Section 308-03.
  - 3rd gear.
  - Synchronizer assemblies for 3rd and 4th gears.
  - 4th gear synchronizer ring. (Figure 1)

Figure 1

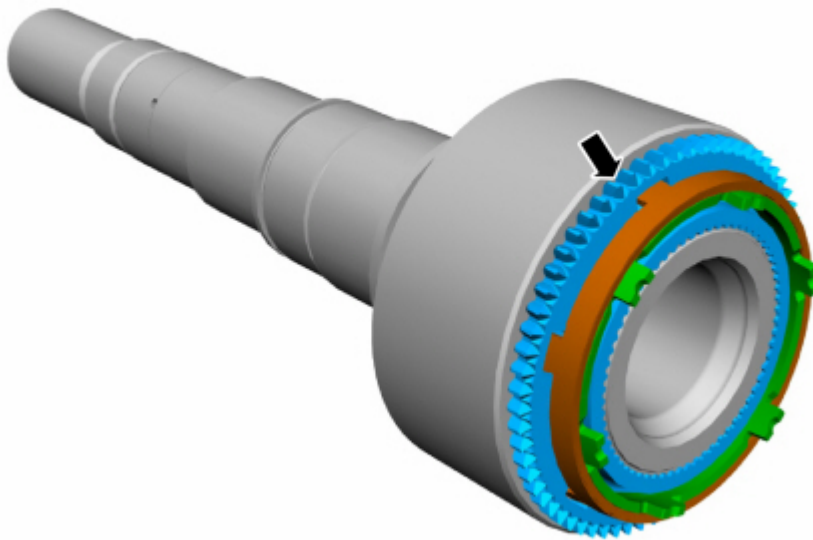

E416092

- Inspect and replace any other damaged parts as needed.

**NOTE: 3rd gear is part of the input shaft. The 4th gear assembly is part of the output shaft assembly and does not require replacement, unless damage is found. In this transmission 4th gear uses a synchronizer ring to align the synchronizer assembly with the gear during shifts.**

5. Assemble the transmission. Refer to WSM, Section 308-03.
6. Install the transmission. Refer to WSM, Section 308-03.

and Extended Service Plan documentation determine Warranty and/or Extended Service Plan coverage unless stated otherwise in the TSB article. The information in this Technical Service Bulletin (TSB) was current at the time of printing. Ford Motor Company reserves the right to supersede this information with updates. The most recent information is available through Ford Motor Company's on-line technical resources.