



# TECHNICAL SERVICE BULLETIN

## Chatter/Shudder During Low Speed Turning Events

**23-2335**

26 October  
2023

### Model:

<b>Ford</b> 2021-2023 Bronco Sport	Engine: 1.5L EcoBoost - Vehicles built on or before 30-Nov-2022 Engine: 2.0L EcoBoost - Vehicles built on or before 28-Feb-2022
2020-2022 Escape	Engine: 1.5L EcoBoost Engine: 2.0L EcoBoost Built on or before 30-Apr-2022
<b>Lincoln</b> 2020-2022 Corsair	Engine: 2.0L EcoBoost Engine: 2.3L EcoBoost Built on or before 30-Apr-2022

**Issue:** Some 2021-2023 Bronco Sport vehicles equipped with a 1.5L engine built on or before 30-Nov-2022, 2021-2023 Bronco Sport vehicles equipped with a 2.0L engine built on or before 28-Feb-2022 or 2020-2022 Escape/Corsair non-plug in hybrid electric vehicle (PHEV) vehicles built on or before 30-Apr-2022 may exhibit a chatter/shudder during low speed turning events. This may be due to contamination of the rear drive unit (RDU) fluid through the RDU vent hose. To correct the condition, follow the Service Procedure to replace the RDU vent hose.

**Action:** Follow the Service Procedure to correct the condition on vehicles that meet all of the following criteria:

- One of the following vehicles:
  - 2021-2023 Bronco Sport vehicles equipped with a 1.5L engine built on or before 30-Nov-2022
  - 2021-2023 Bronco Sport vehicles equipped with a 2.0L engine built on or before 28-Feb-2022
  - 2020-2022 Escape/Corsair (non-PHEV) vehicles built on or before 30-Apr-2022
- Exhibits a chatter/shudder during low speed turning events

### Parts - One Of The Following Sealants (Step 17)

Service Part Number	Quantity	Description
TA-2-B	As Needed	Motorcraft® Seam Sealer
Obtain Locally	As Needed	3M 08308
Obtain Locally	As Needed	LORD Fusor 803DTM

### Parts - Bronco Sport 2.0L

Service Part Number	Quantity	Description	Unit of Issue	Piece Quantity
LX6Z-4022-C	1	RDU Vent Hose	1	1
W718014-S450	1	Stud Rivet	1	1
6C2Z-4N282-AA	2	Drain Plug	1	2
XY-75W-QL	As Needed	Motorcraft® SAE 75W Disconnect Rear Drive Unit Fluid		

### Parts - Bronco Sport 1.5L / All Escape

Service Part Number	Quantity	Description	Unit of Issue	Piece Quantity
K2GZ-4022-M	1	RDU Vent Hose	1	1
W718014-S450	1	Stud Rivet	1	1
6C2Z-4N282-AA	2	Drain Plug	1	2

XY-75W-QL	As Needed	Motorcraft® SAE 75W Disconnect Rear Drive Unit Fluid		
-----------	-----------	--	--	--

### Parts - Corsair

Service Part Number	Quantity	Description	Unit of Issue	Piece Quantity
K2GZ-4022-L	1	RDU Vent Hose	1	1
W718014-S450	1	Stud Rivet	1	1
6C2Z-4N282-AA	2	Drain Plug	1	2
XY-75W-QL	As Needed	Motorcraft® SAE 75W Disconnect Rear Drive Unit Fluid		

Quantity refers to the amount of the service part number required to repair the vehicle.

Unit of Issue refers to the number of individual pieces included in a service part number package.

Piece Quantity refers to the total number of individual pieces required to repair the vehicle.

As Needed indicates the amount of the part may vary and/or is not a whole number. Parts can be billed out as non-whole numbers, including less than 1.

### Special Tool(s)

Hand Stud Rivet Setter Kit Metric Item #AST1455
--

**Warranty Status:** Eligible under provisions of New Vehicle Limited Warranty (NVLW)/Service Part Warranty (SPW)/Special Service Part (SSP)/Extended Service Plan (ESP) coverage. Limits/policies/prior approvals are not altered by a TSB. NVLW/SPW/SSP/ESP coverage limits are determined by the identified causal part and verified using the OASIS part coverage tool.

### Labor Times

Description	Operation No.	Time
2021-2022 Escape 1.5L/2.0L: Replace The RDU Vent Hose Following The Service Procedure (Do Not Use With Any Other Labor Operations)	232335A	0.9 Hrs.
2021-2022 Corsair: 2.0L/2.3L: Replace The RDU Vent Hose Following The Service Procedure (Do Not Use With Any Other Labor Operations)	232335B	0.9 Hrs.
2021-2022 Bronco Sport 2.0L, 2021-2023 Bronco Sport 1.5L: Replace The RDU Vent Hose Following The Service Procedure (Do Not Use With Any Other Labor Operations)	232335C	0.9 Hrs.

### Repair/Claim Coding

Causal Part:	4022
Condition Code:	07

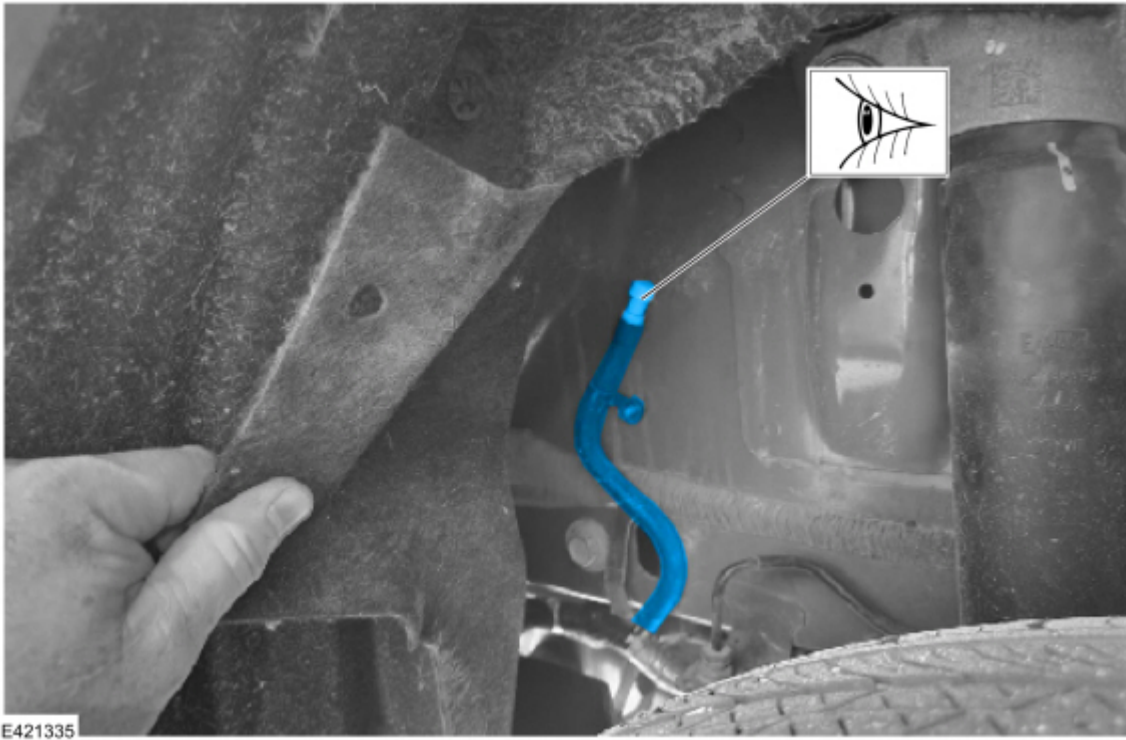
### Service Procedure

1. Remove the right rear fender splash shield retaining pin and fold back the right rear fender splash shield to inspect the RDU vent hose. (Figures 1-2)

Figure 1

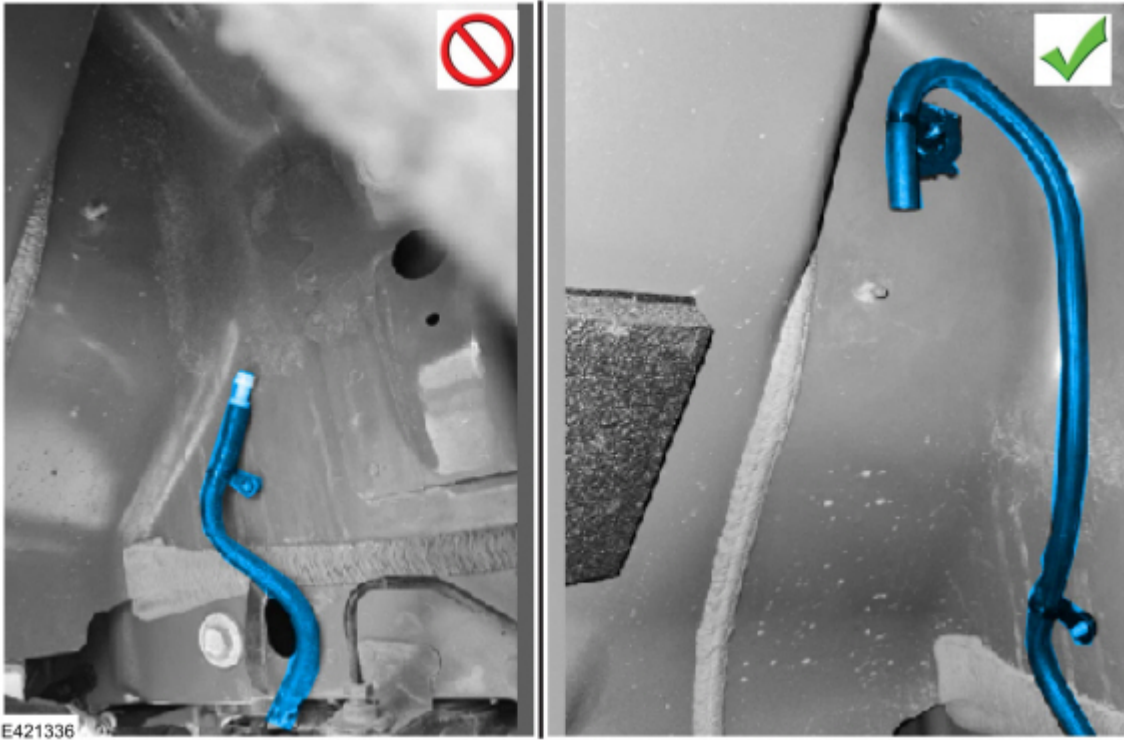


Figure 2



2. Inspect the RDU vent hose mounted behind the right rear fender splash shield. Is the vehicle equipped with the updated RDU vent hose as shown in the image with the green check mark in Figure 3?

Figure 3



E421336

- (1). Yes - this article does not apply. Continue with normal diagnosis.
  - (2). No - proceed to Step 3.
- 3.** Remove the right rear wheel. Refer to Workshop Manual (WSM), Section 204-04A.
  - 4.** Remove the retainers and screws from the right rear fender splash shield shown in Figures 4-6. Lower and fold the right rear fender splash shield in front of the brake caliper to access the RDU vent hose and upper section of the wheel well.

Figure 4



E421337

Figure 5



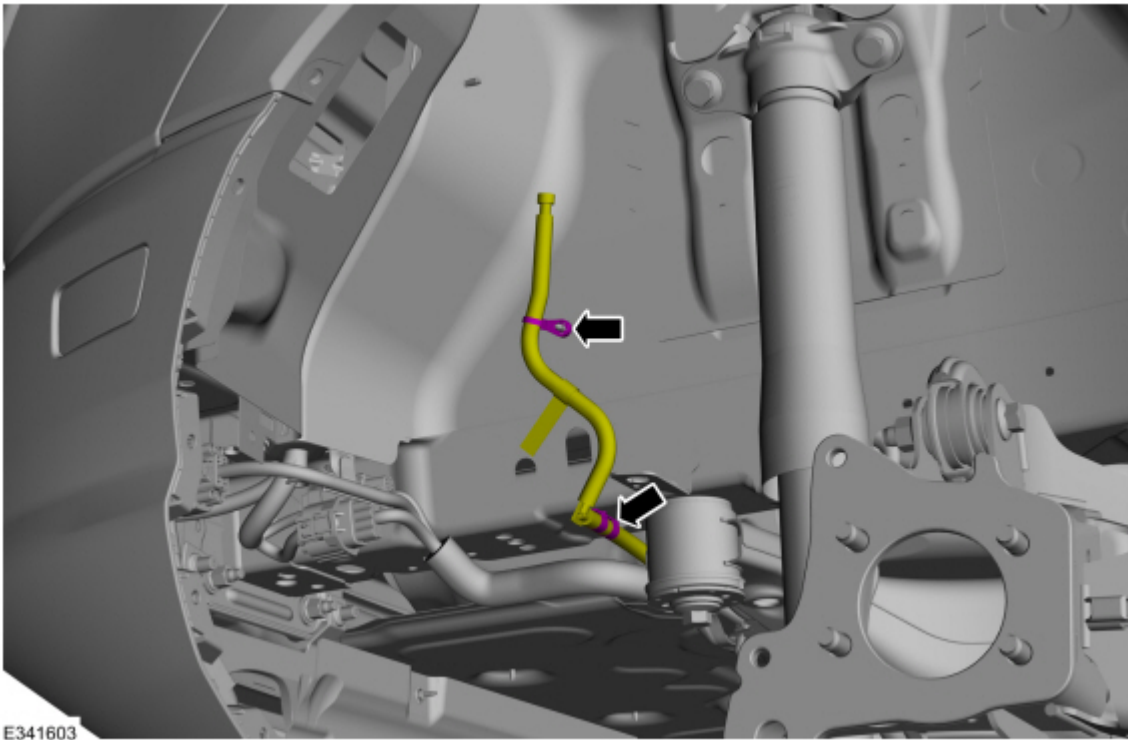
E421338

Figure 6

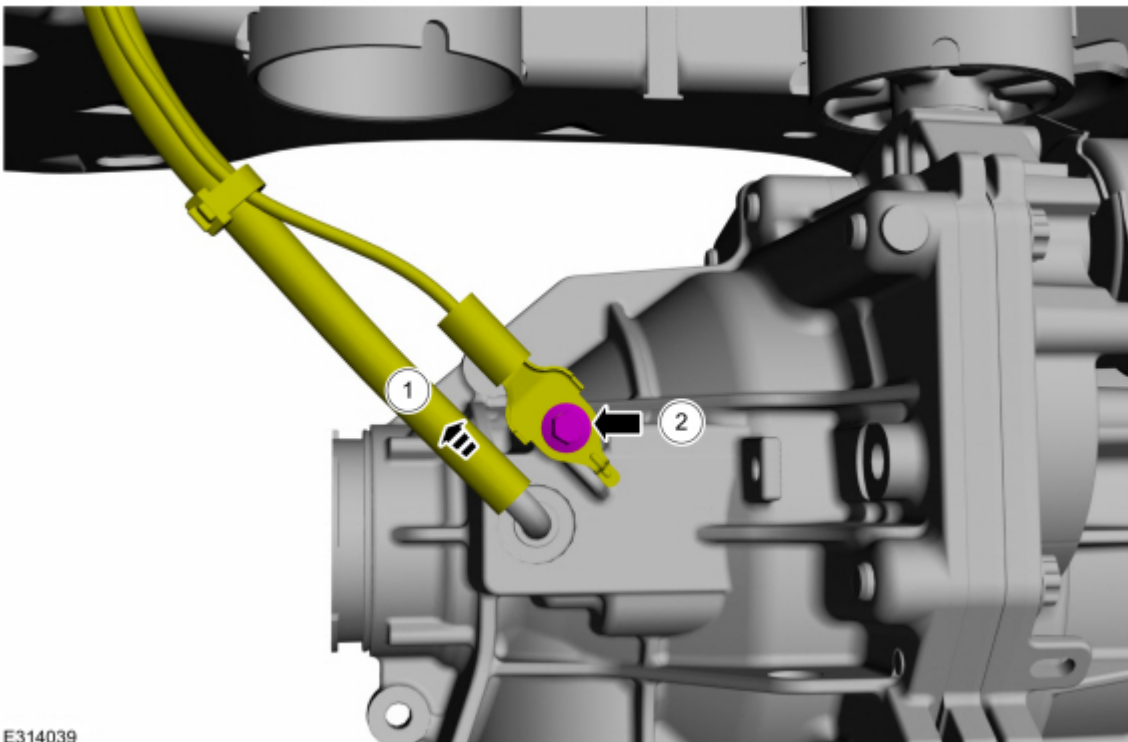


5. Disconnect the RDU vent hose retainers. (Figure 7)

Figure 7

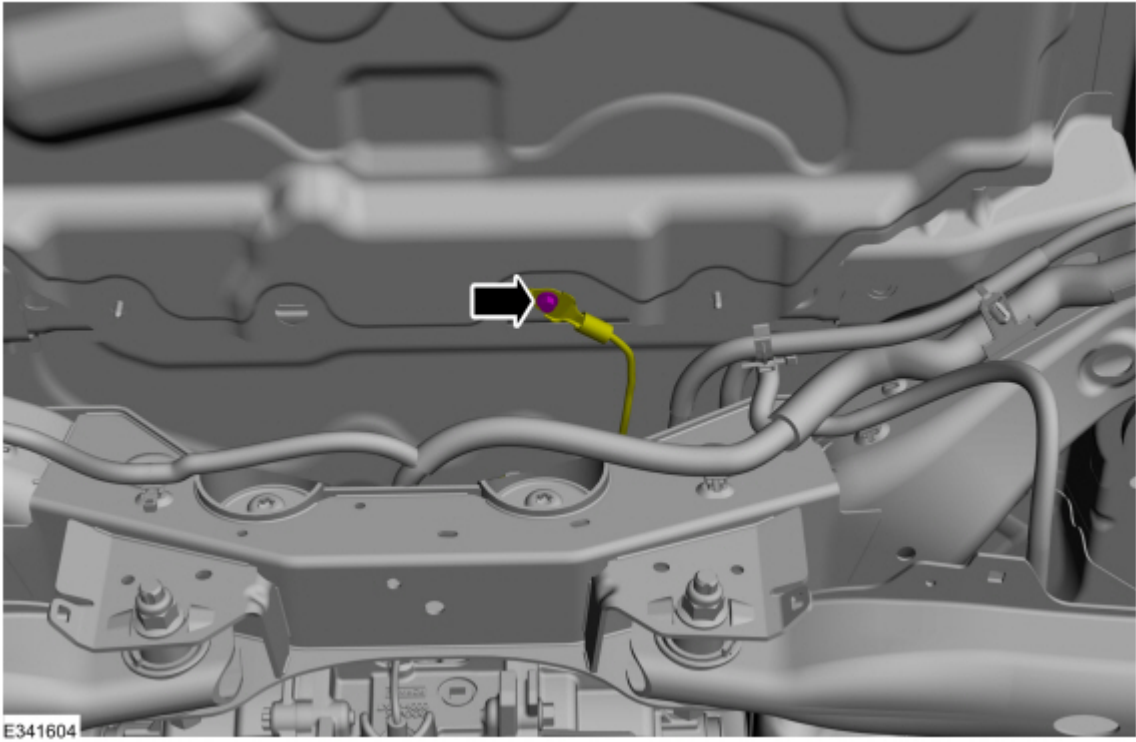


6. Remove the rear differential vent hose and ground strap bolt from the RDU and position aside. (Figure 8)  
Figure 8 - Bronco Sport 1.5L/Escape/Corsair shown, Bronco Sport 2.0L similar



7. Remove the ground strap bolt from the body. (Figure 9)  
Figure 9



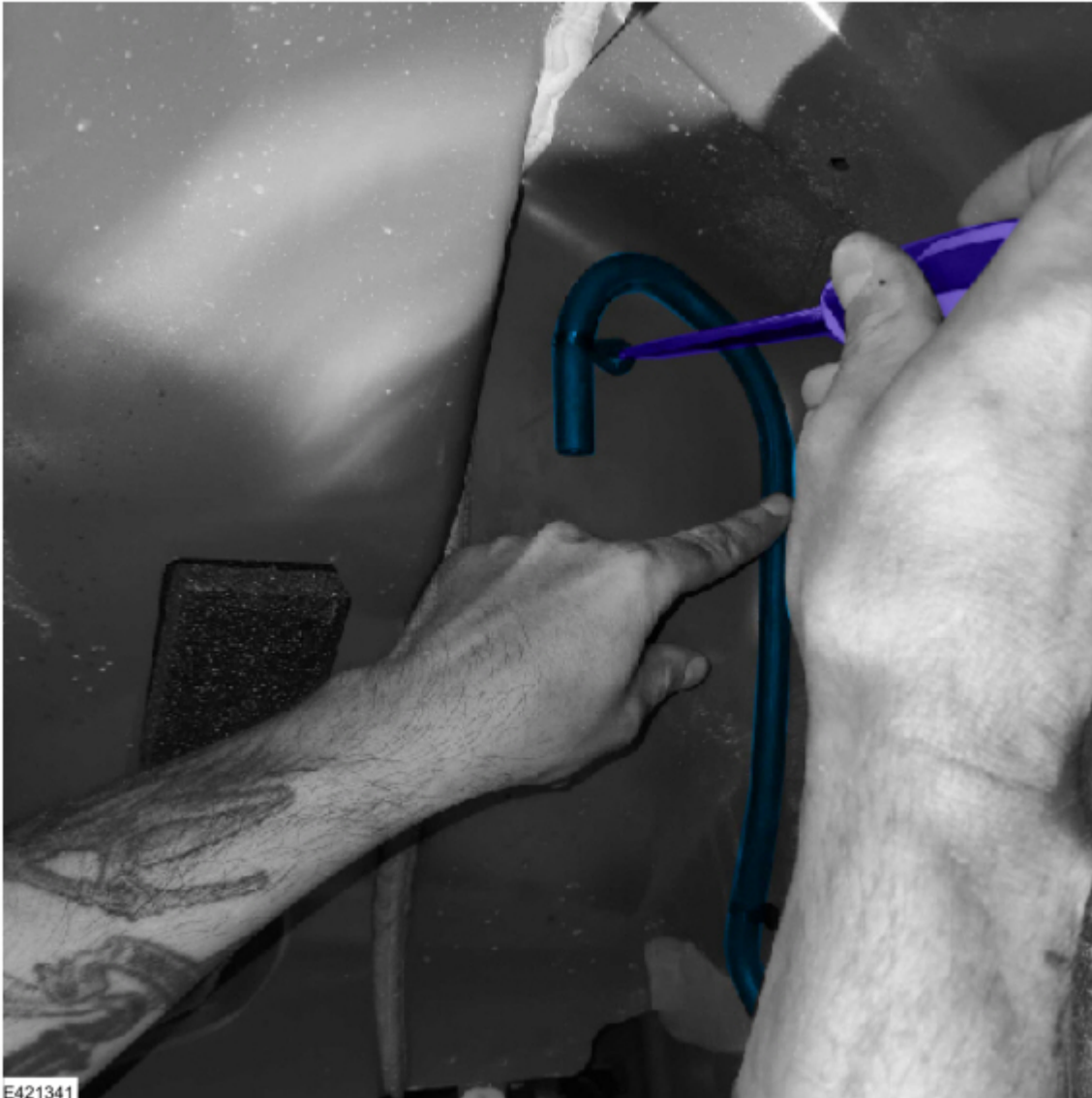


8. Detach the hose retainer and remove the RDU vent hose and ground cable assembly. (Figure 10)  
Figure 10



9. Position the new RDU vent hose and ground strap assembly and attach the hose retainers. (Figures 7 and 10)
10. Install the bolt to attach the ground strap to the body. Tighten to 12 Nm (106 lb.in). (Figure 9)
11. Install the new RDU vent hose onto the RDU. (Figure 8)
12. Install the bolt to secure ground cable onto RDU. Tighten to 12 Nm (106 lb.in). (Figure 8)
13. Using the new retainer at the end of the new RDU vent hose, position the hose vertically so the form of the hose follows the inner arch of the wheel well. Use a tool or a marker to mark the location on the body to drill a hole. (Figure 11)

Figure 11



14. Position the RDU vent hose aside.

**⚠ CAUTION: A depth stopper on the drill bit is necessary to prevent damage to the interior trim.**

15. Using a 10 mm (25/64 in.) drill bit with a depth stopper that leaves only 7 mm (1/4 in.) of the end of the drill bit exposed, drill a hole at the location marked in Step 13.

16. Deburr and clean the hole drilled in Step 15. Temporarily dry fit the stud rivet in the body to make sure the stud rivet is properly seated, then remove the stud rivet.

17. Apply a generous amount of sealant to the body side of the stud rivet. (Figure 12)

Figure 12



E421342

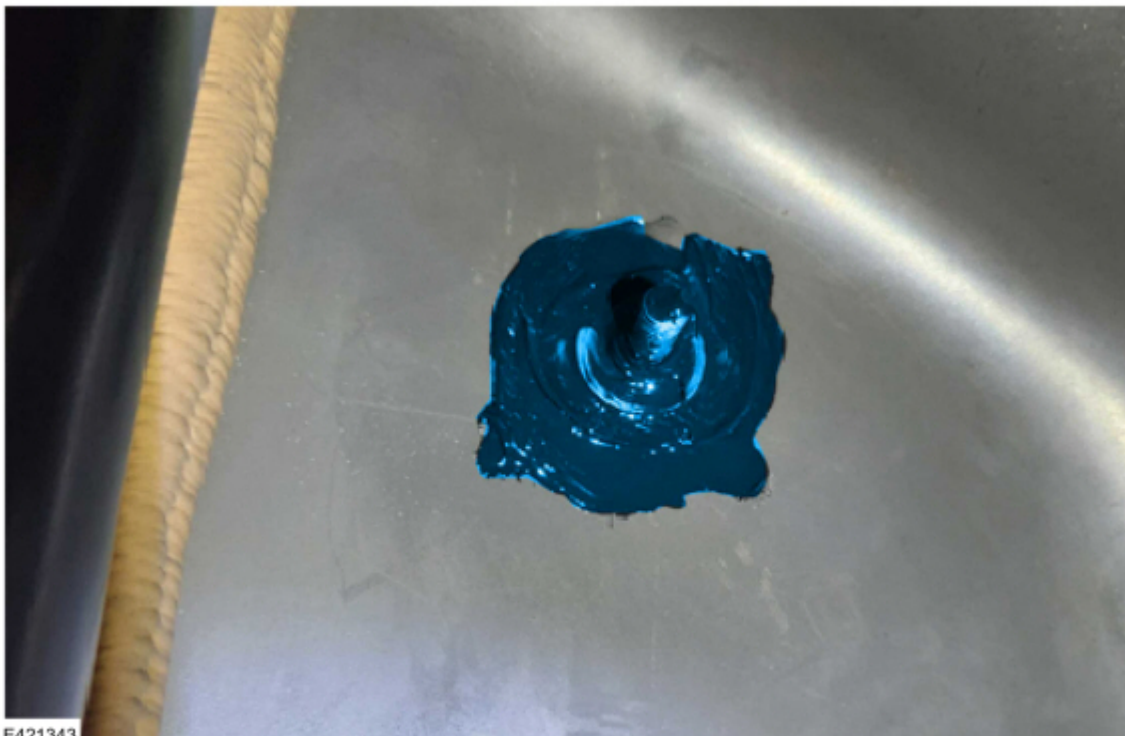
**!** **CAUTION:** Failure to properly seal the stud rivet could lead to water entry into the passenger area.

18. Insert the stud rivet and secure using the stud rivet tool.

19. Spread the excess sealant around the rivet collar as well as the base of the stud to confirm adequate sealing. (Figure 13)

**NOTE:** It is not necessary to wait for the sealant to dry before reassembly.

Figure 13



E421343

20. Attach the hose retainer to the new stud.

21. Reassemble the right rear fender splash shield and secure using the retainers and locations shown in Figures 4-6.

**22.** Install the right rear wheel. Refer to WSM, Section 204-04A.

**23.** Drain and fill the RDU. Refer to WSM, Section 205-02A.

---

© 2023 Ford Motor Company

All rights reserved.

NOTE: The information in Technical Service Bulletins is intended for use by trained, professional technicians with the knowledge, tools, and equipment to do the job properly and safely. It informs these technicians of conditions that may occur on some vehicles, or provides information that could assist in proper vehicle service. The procedures should not be performed by "do-it-yourselfers". Do not assume that a condition described affects your car or truck. Contact a Ford or Lincoln dealership to determine whether the Bulletin applies to your vehicle. Warranty Policy and Extended Service Plan documentation determine Warranty and/or Extended Service Plan coverage unless stated otherwise in the TSB article. The information in this Technical Service Bulletin (TSB) was current at the time of printing. Ford Motor Company reserves the right to supersede this information with updates. The most recent information is available through Ford Motor Company's on-line technical resources.