



TECHNICAL SERVICE BULLETIN

Moan Noise In The Rear Brakes When Vehicle Is Driven In Reverse (R) In Cold Weather And/Or High Humidity

23-2308
09 October 2023

This bulletin supersedes 23-2041.

Model:

Ford
2021-2023 Bronco Sport
2020-2023 Escape

Summary

This article supersedes TSB 23-2041 to update the Issue, Action and Service Procedure.

Issue: Some 2020-2023 Escape and 2021-2023 Bronco Sport vehicles may exhibit a moan noise when the vehicle is driven in reverse (R) in cold weather and/or high humidity. This may be due to the suspension sensitivity of the vehicle. To correct this condition, follow the Service Procedure to replace the standard and reinforced rear caliper bushings and apply Klüberpaste® to the machined surfaces of the brake caliper and caliper support bracket.

Action: Follow the Service Procedure to correct the condition on vehicles that meet all the following criteria:

- One of the following vehicles:
 - 2020-2023 Escape
 - 2021-2023 Bronco Sport
- Moan noise when the vehicle is driven in reverse (R) in cold weather and/or high humidity

Parts

Service Part Number	Quantity	Description	Unit of Issue	Piece Quantity	Note
DG9Z-2C150-C	2	Rear Reinforced Bushing Kit	1 Kit	1 Kit Per Caliper	Kit contains:2 guide pins, 2 guide pin caps, 1 standard bushing 1 reinforced bushing, 1 packet of Klüberpaste®
DG9Z-2B486-B	2	Brake Caliper Spring	1	2	
Obtain Locally	1	1/2 Inch Drum Sander Bit			
XG-3-A	As Needed	Motorcraft® Silicone Brake Caliper Grease and Dielectric Compound			
PM-4-A	As Needed	Motorcraft® Metal Brake Parts Cleaner (Compliant With Low Volatile Organic Compound Requirements As Required In Some USA States)			
PM-4-B	As Needed	Motorcraft® Metal Brake Parts Cleaner (Not Compliant With Volatile Organic Compound Requirements)			

Warranty Status: Eligible under provisions of New Vehicle Limited Warranty (NVLW)/Service Part Warranty (SPW)/Special Service Part (SSP)/Extended Service Plan (ESP) coverage. Limits/policies/prior approvals are not altered by a TSB. NVLW/SPW/SSP/ESP coverage limits are determined by the identified causal part and verified using the OASIS part coverage tool.

Labor Times

Description	Operation No.	Time
2020-2023 Escape, 2021-2023 Bronco Sport: Replace The All Caliper Bushings and Guide Pins On Both (2) Rear Brake Calipers Following The Service Procedure Includes Time To Clean Bushing Housing And Add Grease (Do Not Use With Any Other Labor Operations)	232308A	1.2 Hrs.

Repair/Claim Coding

Causal Part:	2C150
Condition Code:	42

Service Procedure

Bronco Sport

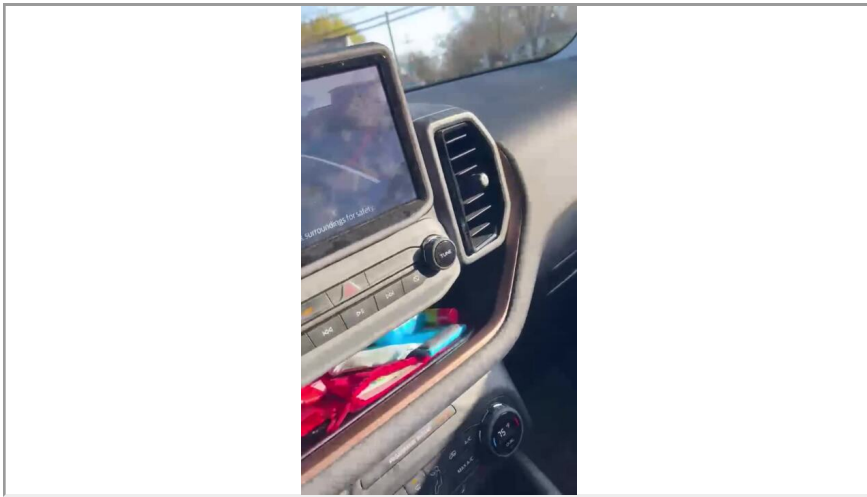

Escape



NOTE: Perform this procedure on both rear calipers.

1. Activate the brake service mode. Refer to the Workshop Manual (WSM), Section 206-00 Brake System > General Information > General Procedures.
2. Remove the wheel and tire. Refer to the WSM, Section 204-04A Wheels and Tires > Removal and Installation.
3. Remove and discard the brake caliper spring. (Figure 1)

Figure 1

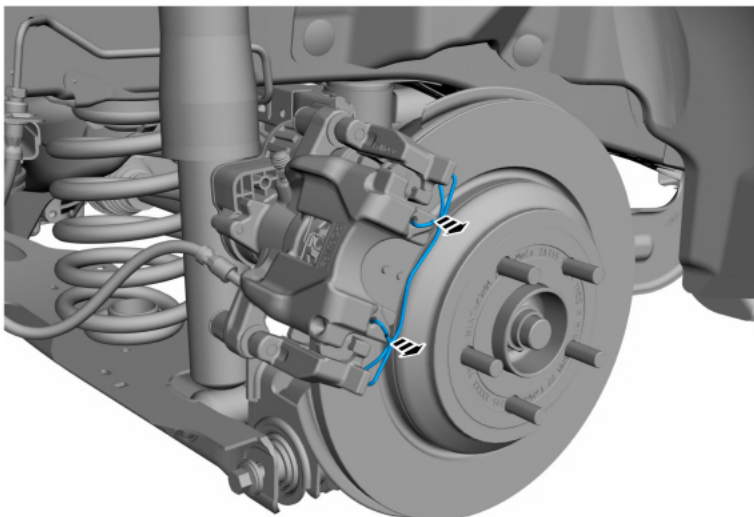

E312184

4. Disconnect the parking brake electrical connector. (Figure 2)

Figure 2

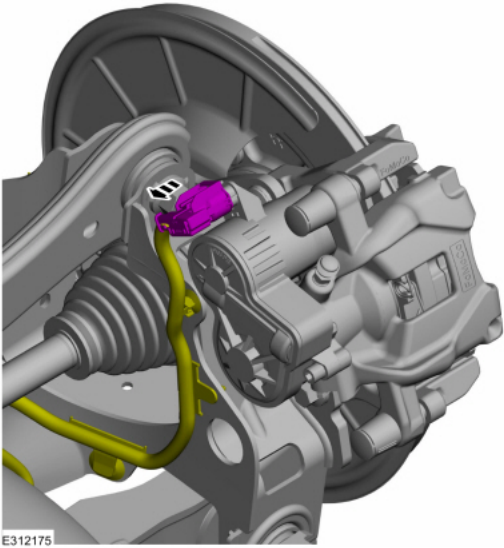

E312175

5. Remove and discard the brake caliper guide pin cap and guide pin on the opposite side of the bleeder. (Figures 3-5)
Figure 3

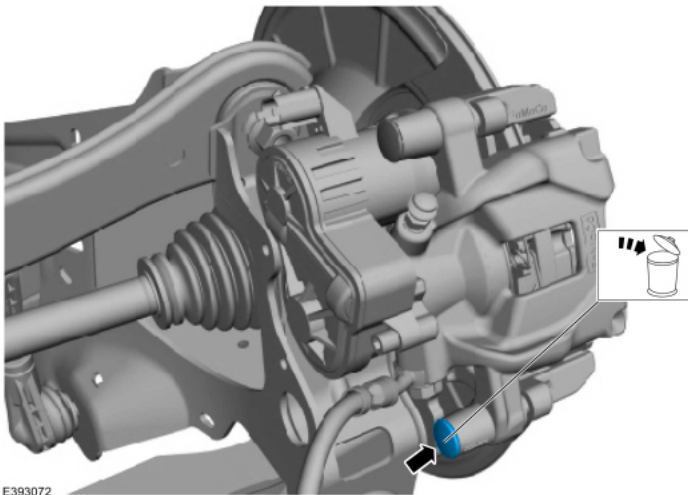

E393072

Figure 4



E393073

Figure 5



6. Loosen the upper guide pin and rotate the rear caliper upwards to gain access to the bushing housing. (Figure 6, Callout 1)

Figure 6

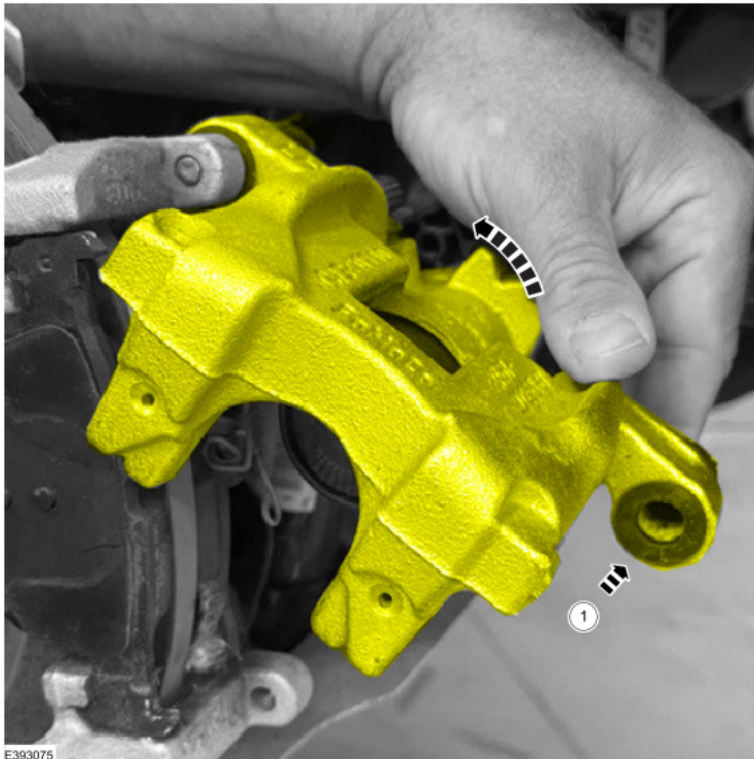

7. Using 6 inch slip joint pliers, remove and discard the standard bushing located on the opposite side of the bleeder. (Figure 7)

Figure 7



E393076

8. Install a new reinforced caliper bushing.

NOTE: The kit includes: 1 standard bushing (Figure 8, Callout 1), 1 reinforced bushing (Figure 8, Callout 2), 2 guide pins (Figure 8, Callout 3), 2 guide pin caps (Figure 8, Callout 4) and 1 packet of Klüberpaste® (Figure 8, Callout 5)

Figure 8



E419779

Item	Description
1	Standard bushing (1 piece)
2	Reinforced bushing (1 piece)
3	Guide pins (2 pieces)
4	Guide pin caps (2 pieces)
5	Packet of Klüberpaste®

(1). Use a 1/2 inch drum sander bit to clean the caliper bushing housing. (Figure 9)

Figure 9

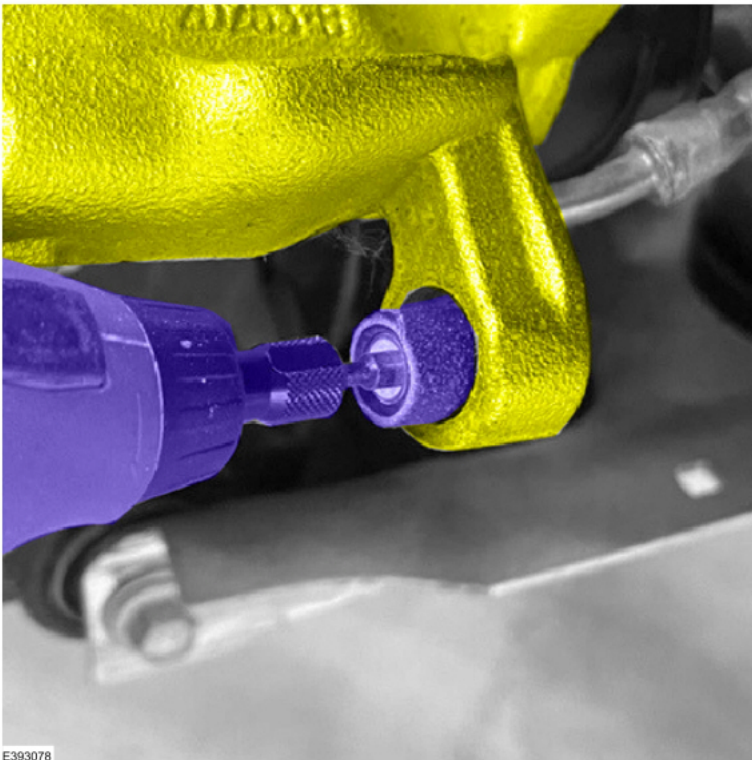

E393078

(2). Use Motorcraft® Metal Brake Parts Cleaner to remove any brake dust from the bushing housing.

(3). Lubricate the bushing and bushing housing with Motorcraft® Silicone Brake Caliper Grease. (Figures 10-11)

Figure 10



E393079

Figure 11



E393080

(4). Use an appropriate diameter socket, such as a 13 mm 3/8 drive chrome deep socket, to push the bushing into the caliper bushing housing. (Figures 12-14)

NOTE: Use a plastic trim tool to help guide the bushing into the housing.

Figure 12

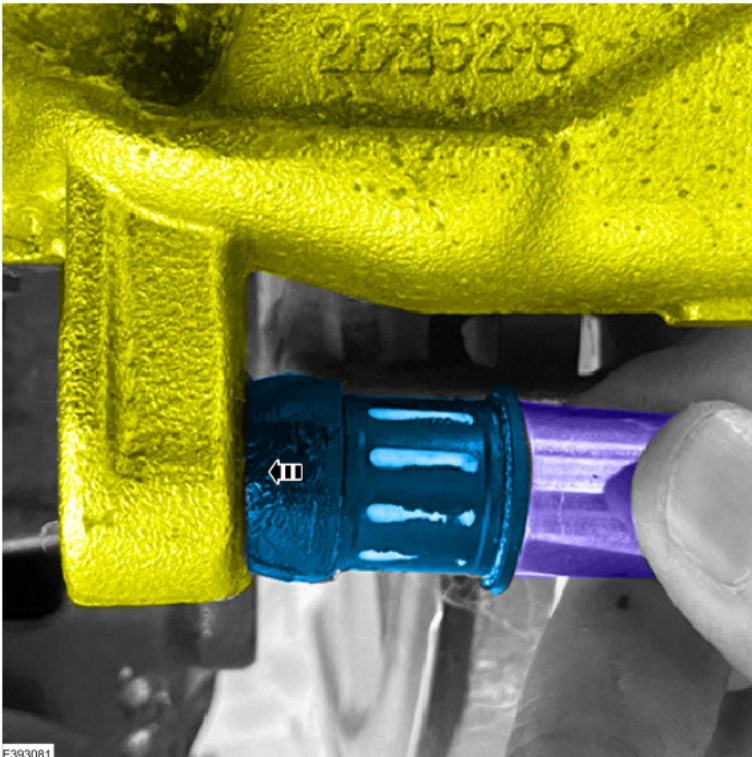

E393081

Figure 13

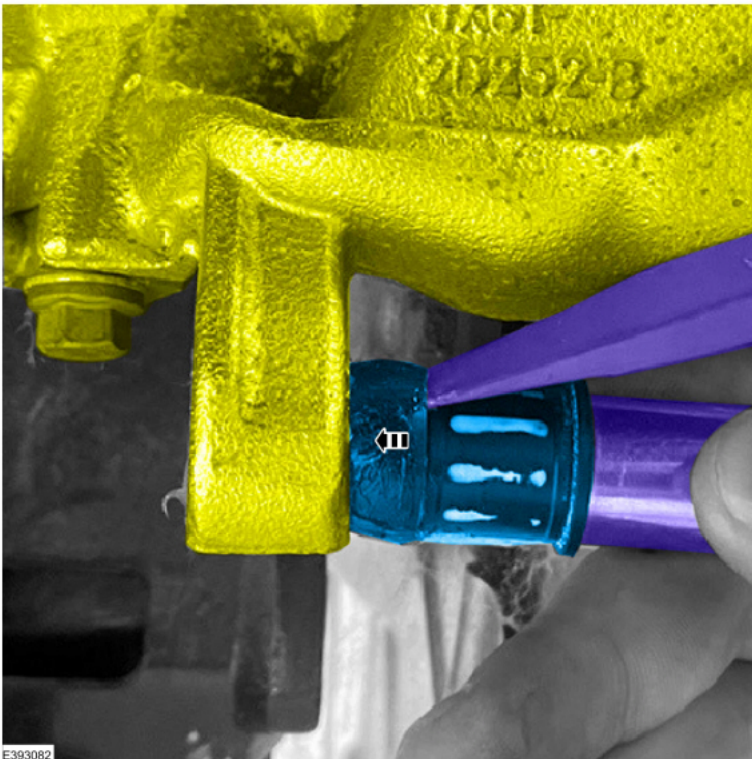
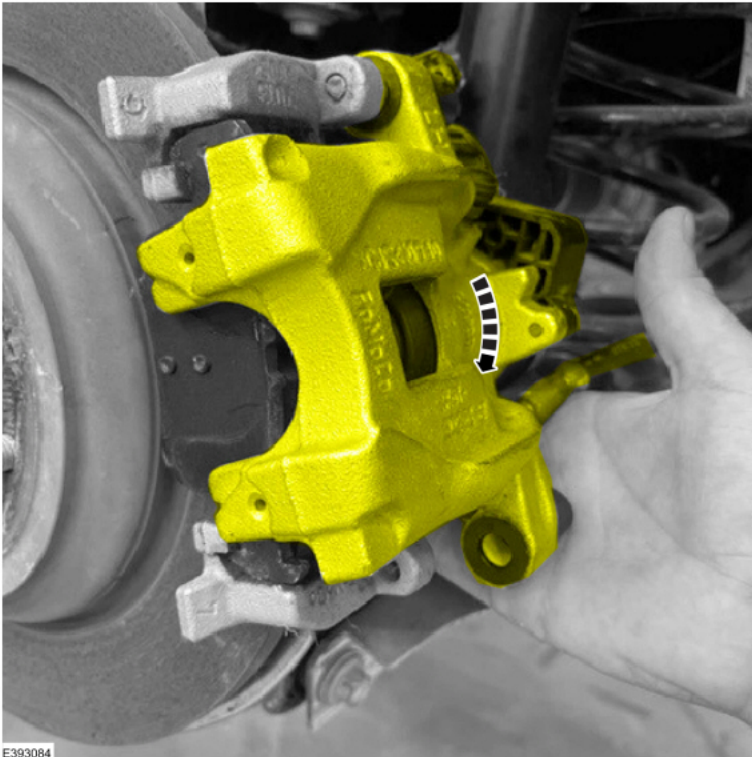

Figure 14



9. Position the rear caliper in place and install a new guide pin. (Figure 15)

Figure 15



E393084

- (1). Lubricate the guide pin with Motorcraft® Silicone Brake Caliper Grease.
- (2). Tighten the lower pin enough to rotate the caliper.

10. Remove and discard the upper brake caliper guide pin cap and guide pin beside the bleeder. (Figure 16)

Figure 16

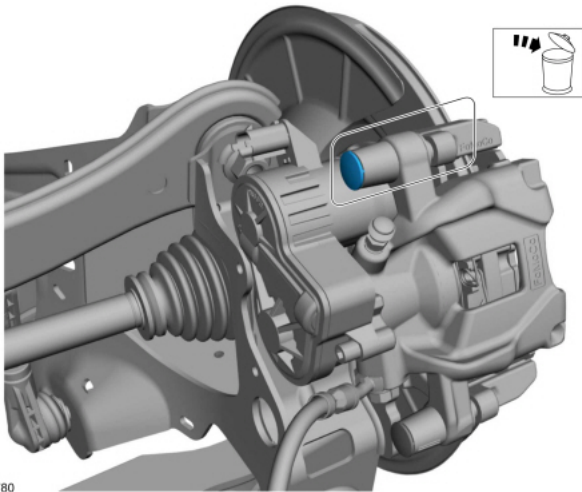

E419780

- 11.** Rotate the caliper downwards to gain access to the bushing housing.
- 12.** Using 6 inch slip joint pliers, remove and discard the standard bushing located beside the bleeder.
- 13.** Install a new standard bushing.
 - (1). Use a 1/2 inch drum sander bit to clean the caliper bushing housing.
 - (2). Use Motorcraft® Metal Brake Parts Cleaner to remove any brake dust from the bushing housing.
 - (3). Lubricate the bushing and bushing housing with Motorcraft® Silicone Brake Caliper Grease.
 - (4). Use an appropriate diameter socket, such as a 13 mm 3/8 drive chrome deep socket, to push the bushing into the caliper bushing housing.

NOTE: Use a plastic trim tool to help guide the bushing into the housing.

14. Position the caliper completely downward to gain access to the caliper housing and the brake caliper anchor plate.

15. Remove the outboard brake pad (Figure 17)

Figure 17

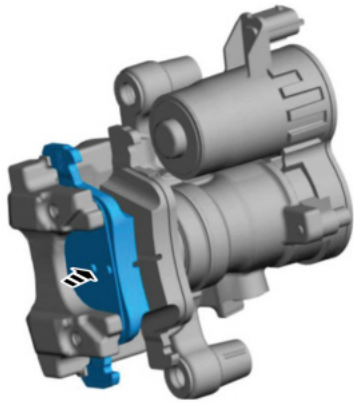

E419781

16. Use Motorcraft® Metal Brake Parts Cleaner and an abrasive pad (super fine grade) to clean the caliper housing at the machined brake pad backplate contact surfaces. (Figures 18-19)

Figure 18

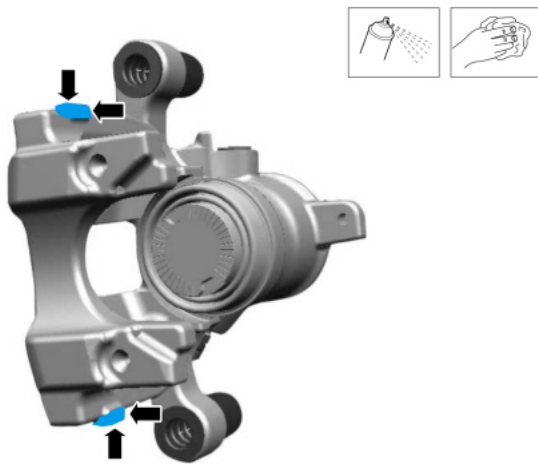

E419782

Figure 19

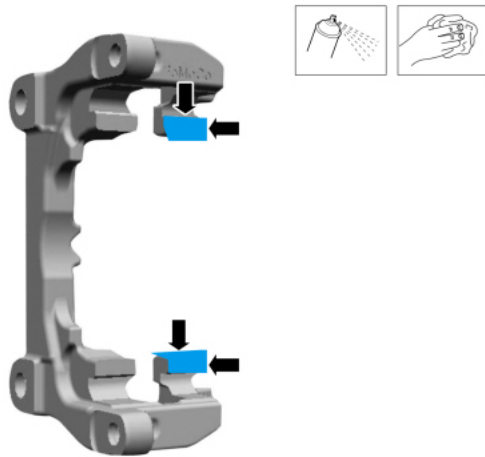

E419783

17. Use compressed air to completely dry the contact areas.

18. Apply Klüberpaste® on the two surfaces of the housing and the two surfaces of the anchor points and below on the leading and trailing sides. (Figure 20-21)

Figure 20

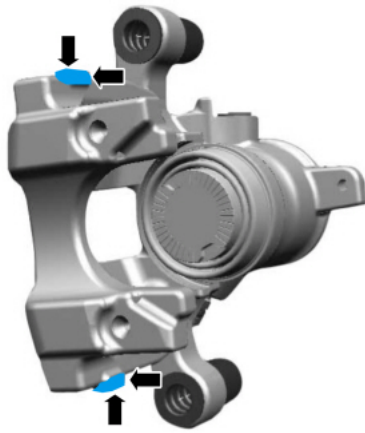

E419784

Figure 21

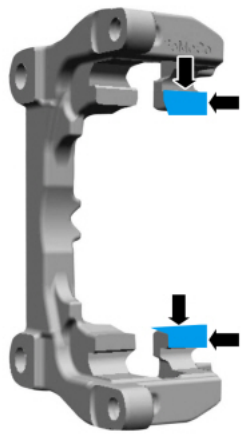

E419785

19. Reinstall the brake pad.
20. Position the caliper in place and install a new guide pin.
 - (1). Lubricate the guide pin with Motorcraft® Silicone Brake Caliper Grease.
 - (2). Tighten both guide pins to 28Nm (21 lb-ft).
21. Install the new guide pin caps.
22. Install a new brake caliper spring.
23. To assemble the vehicle, reverse the removal procedure.
24. Deactivate the brake service mode. Refer to the WSM, Section 206-00 Brake System > General Information > General Procedures.

© 2023 Ford Motor Company
All rights reserved.

NOTE: The information in Technical Service Bulletins is intended for use by trained, professional technicians with the knowledge, tools, and equipment to do the job properly and safely. It informs these technicians of conditions that may occur on some vehicles, or provides information that could assist in proper vehicle service. The procedures should not be performed by "do-it-yourselfers". Do not assume that a condition described affects your car or truck. Contact a Ford or Lincoln dealership to determine whether the Bulletin applies to your vehicle. Warranty Policy and Extended Service Plan documentation determine Warranty and/or Extended Service Plan coverage unless stated otherwise in the TSB article. The information in this Technical Service Bulletin (TSB) was current at the time of printing. Ford Motor Company reserves the right to supersede this information with updates. The most recent information is available through Ford Motor Company's on-line technical resources.