



TECHNICAL SERVICE BULLETIN

MT88 Manual Transmission - No 3rd Gear And/Or Grinding Noise Going Into 3rd And/Or 4th Gear

23-2219

31 August
2023

Model:

Ford 2021-2023 Bronco	Transmission: 7-Speed Manual Transmission MT-88
---------------------------------	---

Issue: Some 2021-2023 Bronco vehicles may exhibit no 3rd gear engagement and/or a grinding noise going into 3rd and/or 4th gear. This may be due to the transmission shifting system and clutch interaction such as a lack of full clutch disengagement during shifts and/or placing weight upon the gear shift lever while driving. To correct this condition, follow the Service Procedure to replace the 3rd and/or 4th gears and/or synchronizers as needed.

Action: Follow the Service Procedure to correct the condition if the vehicle meets the following criteria:

- 2021-2023 Bronco
- Equipped with MT88 manual transmission
- At least one of the following:
 - Grinding noise going into 3rd and/or 4th gear
 - Will not go into 3rd gear

Parts

Service Part Number	Claim Quantity	Package Order Quantity	Number in Package	Description	Note
MU7Z-7M157-A	1	1	1	Synchronizer Ring Plate	
MU7Z-7101-A	1	1	1	3rd Gear And Cone Assembly	
MU7R-7107-D	1	3	1	Synchronizer Ring	
MU7Z-7W441-A	1	1	1	Gear Shift Lever Pin	
MU7Z-7048-A	1	1	1	Input Shaft Seal	
BR3Z-7052-A	1	1	1	Rear Oil Seal	
MU7Z-7124-E	1	1	1	Synchronizer Assembly	
MU7Z-7P497-A	1	1	1	Counter Shaft Bore Plug	This may be called Compression Ring
BR3Z-7064-A	1	1	1	Input Shaft Snap-Ring	
MU7Z-3K050-A	1	2	1	Reverse/Crawl Gear Snap-Ring	
MU7Z-3K050-B	2	2	1	6th Gear Snap-Ring	
MU7Z-3K050-C	1	1	1	4th Gear Snap-Ring	
JB3Z-4B496-B	6	6	1	Front Driveshaft Bolts And Retaining Straps	
LB3Z-4B496-A	8	8	1	Rear Driveshaft Bolts And Retaining Straps	

MB3Z-9450-B	1	1	1	Exhaust Manifold Gasket	
W710624-S300	1	1	1	Roll Pin Reverse/Crawl Shift Fork	
W500121-S439	1	4	4	Transfer Case Bolts	
W520103-S442	1	4	4	Exhaust Flange Nut	
ZC-20	As Needed	As Needed	1	Motorcraft® Engine Shampoo and Degreaser	
TA-357	As Needed	As Needed	1	Motorcraft® High Performance Engine RTV Silicone	
XT-11-QDC	As Needed	As Needed	1	Dual Clutch Transmission Fluid	
PM-4-A	As Needed	As Needed	1	Motorcraft® Metal Brake Parts Cleaner	
ZC-31-B	As Needed	As Needed	1	Motorcraft® Metal Surface Prep Wipes	
PM-20	As Needed	As Needed	1	Motorcraft® DOT 4 LV High Performance Motor Vehicle Brake Fluid	
ZC-30-A	1	As Needed	1	Motorcraft® Silicone Gasket Remover	

Parts - Parts To Inspect And Replace As Necessary

Service Part Number	Claim Quantity	Package Order Quantity	Number in Package	Description
MU7Z-7230-A	1	1	1	Shift Fork 3rd and 4th Gears

Warranty Status: Eligible under provisions of New Vehicle Limited Warranty (NVLW)/Service Part Warranty (SPW)/Special Service Part (SSP)/Extended Service Plan (ESP) coverage. Limits/policies/prior approvals are not altered by a TSB. NVLW/SPW/SSP/ESP coverage limits are determined by the identified causal part and verified using the OASIS part coverage tool.

Labor Times

Description	Operation No.	Time
2021-2023 Bronco MT88 Transmission: Replace Synchronizer Assemblies for 3rd And 4th Gear And The 4th Gear Synchronizer Ring (Can Be Used With Operation B And Or MT) (Do Not Use With Any Operations Outside Of This Article)	232219A	9.2 Hrs.
Additional Time For Vehicles With Electronic Sway Bar Disconnect (Can Be Used With Operation A)	232219B	0.8 Hrs.
Additional Time To Replace Any Additional Parts Discovered During Inspection (Can Be Used With Operation A)	MT232219	Actual Time

Repair/Claim Coding

Causal Part:	7107
Condition Code:	13

Service Procedure

1. Remove the transmission from the vehicle. Refer to Workshop Manual (WSM), Section 308-03.
2. Disassemble the transmission. Refer to WSM, Section 308-03 > Disassembly > Transmission, Steps 1-34.

3. Remove the output shaft from the transmission case to gain access to the 3rd and 4th gears and synchronizer assemblies. Refer to WSM, Section 308-03 > Disassembly and Assembly of Subassemblies > Input Shaft, Steps 1-5.
4. Replace the following components and any associated damaged parts. Refer to WSM, Section 308-03.
 - 3rd gear.
 - Synchronizer assemblies for 3rd and 4th gears.
 - 4th gear synchronizer ring. (Figure 1)
Figure 2

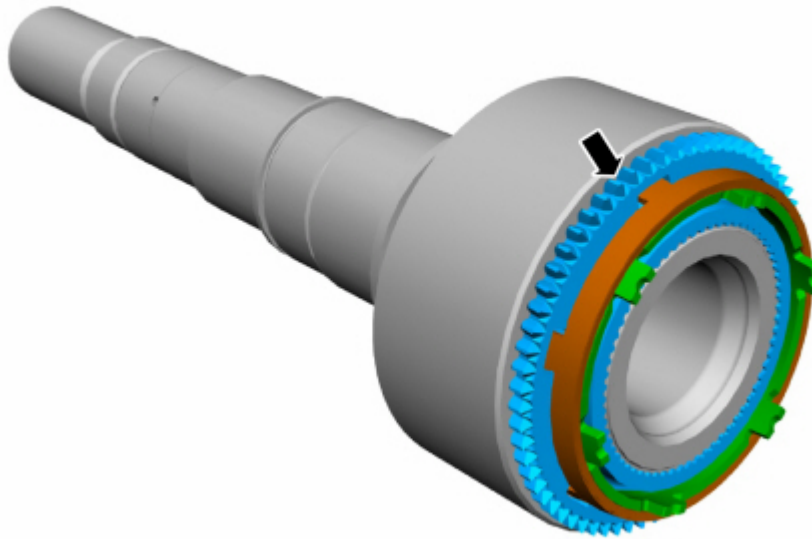

E416092

- Inspect and replace any other damaged parts as needed.

NOTE: 3rd gear is part of the input shaft. The 4th gear assembly is part of the output shaft assembly and does not require replacement, unless damage is found. In this transmission 4th gear uses a synchronizer ring to align the synchronizer assembly with the gear during shifts.

5. Assemble the transmission. Refer to WSM, Section 308-03.
6. Install the transmission. Refer to WSM, Section 308-03.

© 2023 Ford Motor Company
All rights reserved.

NOTE: The information in Technical Service Bulletins is intended for use by trained, professional technicians with the knowledge, tools, and equipment to do the job properly and safely. It informs these technicians of conditions that may occur on some vehicles, or provides information that could assist in proper vehicle service. The procedures should not be performed by "do-it-yourselfers". Do not assume that a condition described affects your car or truck. Contact a Ford or Lincoln dealership to determine whether the Bulletin applies to your vehicle. Warranty Policy and Extended Service Plan documentation determine Warranty and/or Extended Service Plan coverage unless stated otherwise in the TSB article. The information in this Technical Service Bulletin (TSB) was current at the time of printing. Ford Motor Company reserves the right to supersede this information with updates. The most recent information is available through Ford Motor Company's on-line technical resources.