

ATTENTION:

- GENERAL MANAGER
- PARTS MANAGER
- CLAIMS PERSONNEL
- SERVICE MANAGER

IMPORTANT - All Service Personnel Should Read and Initial in the boxes provided, right.



QUALITY DRIVEN® SERVICE

SERVICE BULLETIN

APPLICABILITY: Legacy and Outback 2000-2009MY w/ 5MT
 Forester 1999MY and Later w/ 5MT
 Impreza (Including WRX) 1999MY and Later w/ 5MT

NUMBER: 03-70-12R
DATE: 12/13/12
REVISED: 01/03/13

SUBJECT: Repair Procedure for High-Pitched Sound from Extension Housing Area Using Latest Generation Production Parts

INTRODUCTION

This Bulletin provides production change, repair procedure and parts information to address a customer concern of a high-pitched sound coming from the transmission extension housing area.

In cold temperatures, thermal contraction causes shrinking of the transmission case. In high temperatures, expansion of the case occurs. These temperature changes affect the amount of pre-load on the transfer driven shaft bearings. In some rare cases, when preload is very near the limit of specification combined with unusual driving conditions, this thermally-induced pre-load change may cause damage to the bearings and result in the sound heard by the customer.

A change has been made to the extension case and a new “Dish Plate” added. The machining depth of the extension case has been increased to accommodate the new dish plate. When used along with a selective thrust washer, the spring tension of the dish plate helps to maintain a consistent amount of pre-load on these bearings throughout varying temperature conditions.

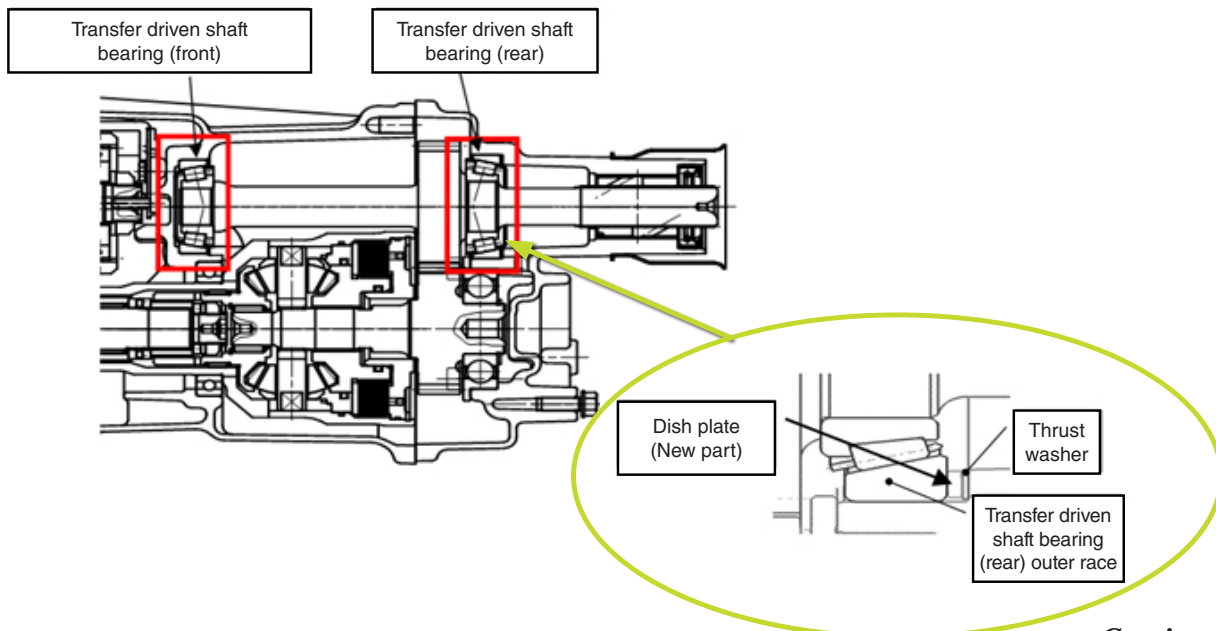

Continued...

CAUTION: VEHICLE SERVICING PERFORMED BY UNTRAINED PERSONS COULD RESULT IN SERIOUS INJURY TO THOSE PERSONS OR TO OTHERS.

Subaru Service Bulletins are intended for use by professional technicians ONLY. They are written to inform those technicians of conditions that may occur in some vehicles, or to provide information that could assist in the proper servicing of the vehicle. Properly trained technicians have the equipment, tools, safety instructions, and know-how to do the job correctly and safely. If a condition is described, DO NOT assume that this Service Bulletin applies to your vehicle, or that your vehicle will have that condition.

SUBARU OF AMERICA, INC. IS "ISO 14001 COMPLIANT"

The international standard for excellence in Environmental Management Systems. Please recycle or dispose of automotive products in a manner that is friendly to our environment and in accordance with all local, state and federal laws and regulations.

COUNTERMEASURE IN PRODUCTION

The chart below indicates the starting vehicle identification numbers (VINs) when the new parts were incorporated in to production.

MODEL	TYPE	STARTING VIN NUMBER
Forester		DG424937
Impreza	4-Door	DG007208
	5-Door	DG212655
WRX	4-Door	DG007203
	5-Door	DG213327

PART INFORMATION

NEW PART NUMBER	DESCRIPTION	OLD PART NUMBER	INTERCHANGEABILITY	NOTES
32130AA350	EXT COMPL	32130AA330	New to Old ONLY	After T/M# 712031
31668AA250	PLATE-DISHED	n/a	n/a	
806322080	ROLL BRG 22X56X17	806322050	New to Old ONLY	T/M# 712031 and before
806330120	ROLL BRG 30X62X17	806330110	New to Old ONLY	

NOTE: When replacing the extension case, the output oil seal, p.n. 806735210 must also be replaced.

SERVICE PROCEDURE / INFORMATION

- See Service Bulletin 03-68-12R for special tool information and a required bearing pre-lubrication procedure (shown below) related to this repair.

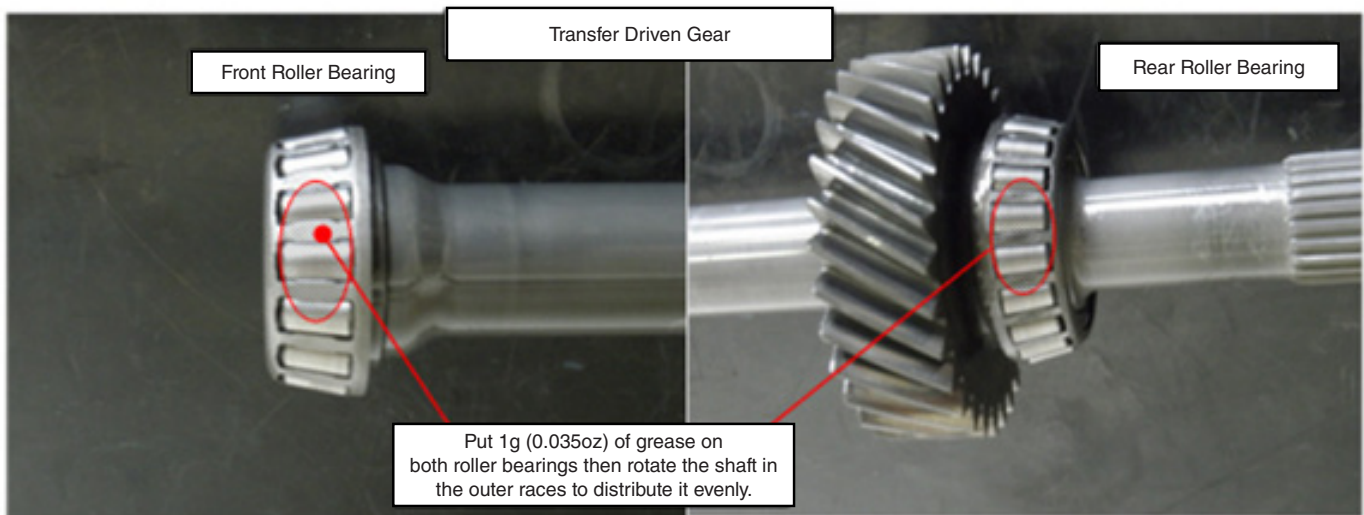

IMPORTANT: If the transfer driven shaft bearings are damaged or failed, **thoroughly** clean and inspect all the internal components of the transmission before reassembly. In very severe cases where metal contamination damage is extensive, transmission assembly replacement may be required. If within the warranty coverage period, completion of an Assembly Repair vs. Replacement worksheet is required.

Continued...

- Follow the procedures in the applicable Service Manual for removal and replacement of the extension case.

NOTE: Both outer races of the transfer driven shaft bearings are hand-fit to their bores and are not press-fit. Turning the outer races slightly will make their installation easier.

MEASUREMENT PROCEDURE

- Measure height “W” between transfer case sealing surface and taper roller bearing outer race on the transfer driven gear.

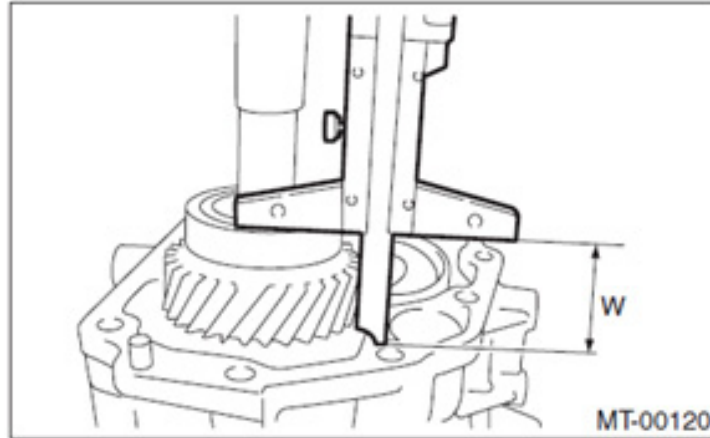

W Measured value

- With the bearing outer race, dish plate and thrust washer removed, measure depth “X” of the bearing bore of the extension case.

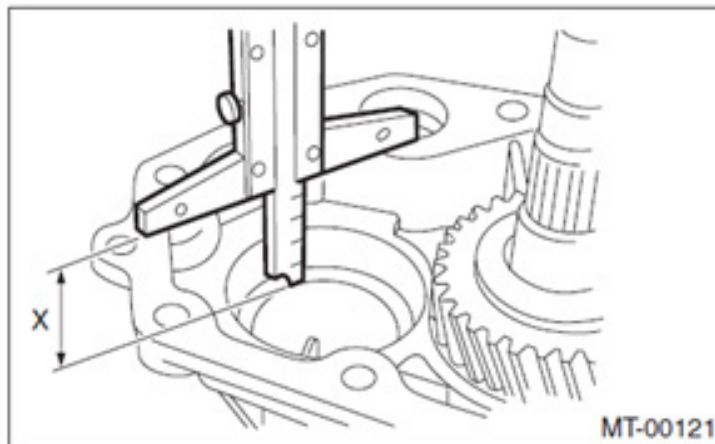

X Measured value

- Calculate the required thrust washer thickness “T” using the revised formula below:

T= X - W - (1.715 to 1.765 mm (0.0686 to 0.0706”)).

NOTE: This formula has been revised from the formula shown in the Service Manual to work with the new dish plate and extension case assembly.

Continued...

- Select the thrust washer with the closest value from the following table:

Thrust washer (50 × 61 × t)	
Part No.	Thickness mm (in)
803050060	0.50 (0.0197)
803050061	0.55 (0.0217)
803050062	0.60 (0.0236)
803050063	0.65 (0.0256)
803050064	0.70 (0.0276)
803050065	0.75 (0.0295)
803050066	0.80 (0.0315)
803050067	0.85 (0.0335)
803050068	0.90 (0.0354)
803050069	0.95 (0.0374)
803050070	1.00 (0.0394)
803050071	1.05 (0.0413)
803050072	1.10 (0.0433)
803050073	1.15 (0.0453)
803050074	1.20 (0.0472)
803050075	1.25 (0.0492)
803050076	1.30 (0.0512)
803050077	1.35 (0.0531)
803050078	1.40 (0.0551)
803050079	1.45 (0.0571)

- Once the proper thrust washer has been selected, assemble the **new** extension case as shown in the illustration below.

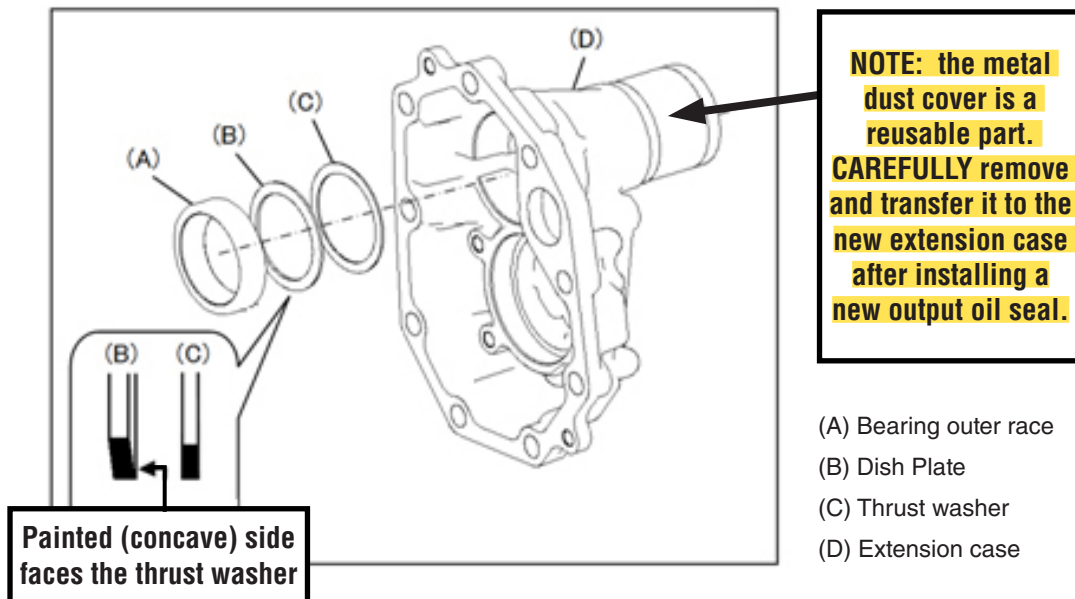

Continued...

- Install a new output oil seal before transferring the original metal dust cover over to the new extension case.
- Follow the procedure in the applicable Service Manual for re-installation of the new extension case assembly to the transfer case.

WARRANTY / CLAIM INFORMATION

For vehicles within the Basic New Car Limited Warranty period, refer to Subaru Warranty Wizard for claim submission information.