

ATTENTION:

- GENERAL MANAGER
- PARTS MANAGER
- CLAIMS PERSONNEL
- SERVICE MANAGER

IMPORTANT - All Service Personnel Should Read and Initial in the boxes provided, right.

| | | |
|--|--|--|
| | | |
| | | |



QUALITY DRIVEN® SERVICE

SERVICE BULLETIN

APPLICABILITY: 2014MY and Later STI Models
SUBJECT: Design Change to Reverse Idler Gear Components

NUMBER: 03-73-14
DATE: 03/10/14

INTRODUCTION

This bulletin informs of a design change to the reverse idler gear and its internal spring along with a revised assembly procedure. The only purpose for the change was to enhance production efficiency.

COUNTERMEASURE IN PRODUCTION

The new reverse idler components were incorporated into production during mid-October, 2013 starting with VIN E*224413.

PART INFORMATION

IMPORTANT: The revised parts listed in the table below **must always be replaced as a set.**

| PART NAME | NEW PART NUMBER |
|------------------|-----------------|
| GEAR-REV IDLER | 32282AA210 |
| SPRING-REV IDLER | 32369AA040 |

The illustrations below provide a reference for identifying differences between the old and new parts.

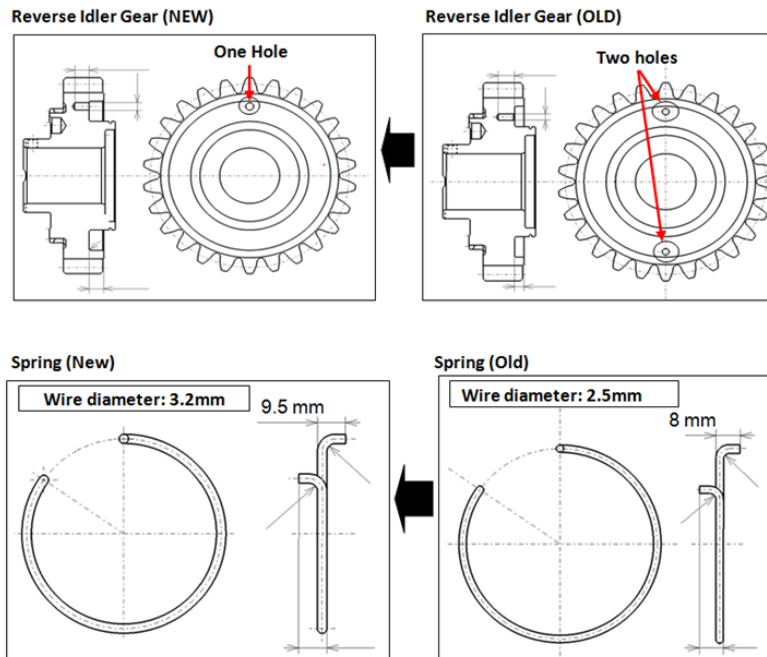

Continued...

CAUTION: VEHICLE SERVICING PERFORMED BY UNTRAINED PERSONS COULD RESULT IN SERIOUS INJURY TO THOSE PERSONS OR TO OTHERS.

Subaru Service Bulletins are intended for use by professional technicians ONLY. They are written to inform those technicians of conditions that may occur in some vehicles, or to provide information that could assist in the proper servicing of the vehicle. Properly trained technicians have the equipment, tools, safety instructions, and know-how to do the job correctly and safely. If a condition is described, DO NOT assume that this Service Bulletin applies to your vehicle, or that your vehicle will have that condition.

SUBARU OF AMERICA, INC. IS "ISO 14001 COMPLIANT"

The international standard for excellence in Environmental Management Systems. Please recycle or dispose of automotive products in a manner that is friendly to our environment and in accordance with all local, state and federal laws and regulations.

SERVICE PROCEDURE / INFORMATION

- Remove and disassemble the transmission as necessary to access the reverse idler gear assembly following the procedure outlined in the applicable Service Manual.
- Once removed from the case, disassemble the old reverse idler gear assembly.
- After a thorough cleaning and inspection of the parts to be reused, re-assemble using the exploded view below as a guide. The friction plate and snap ring are **not** selective parts.

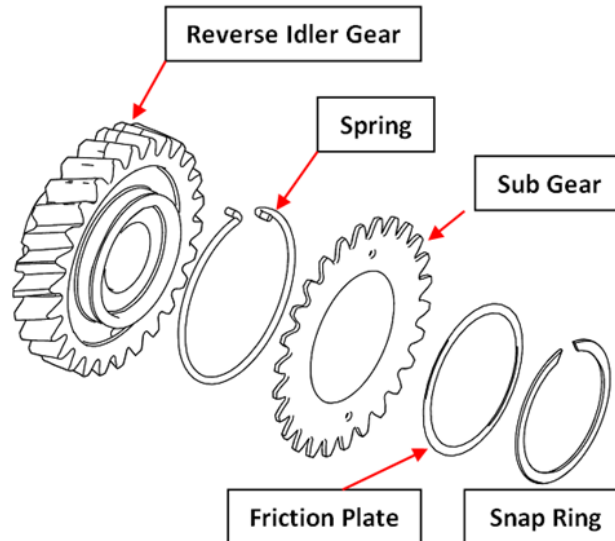

- After the new reverse idler assembly is back together with the new gear and spring, hold the idler gear stationary then rotate the sub gear **COUNTER-CLOCKWISE** (left) **2 teeth** to set the “pre-load” and hold it in that position. **NOTE:** You will need a helper for the next step.
- Using a piece of mechanic’s wire as shown below, left, wrap it around 2 pair of gear teeth (main and sub gear) and twist the ends of the wire together to hold the sub gear in position and maintain the pre-load. Since the new reverse idler gear only has one hole (used by one end of the spring), the mechanic’s wire serves the function of the alignment pin used on the original gear which had the second hole in it.
- Once the assembly has been reinstalled in the case as shown below, right, cut and remove the mechanic’s wire.
- Complete the reassembly following the procedure outlined in the applicable Service Manual.

