



# TECHNICAL SERVICE BULLETIN

## Second Row Seat Back Does Not Fold Down Or Recline

**23-2036**

06 February  
2023

This bulletin supersedes 19-2068.

### Model:

<b>Ford</b> 2018-2023 Expedition
<b>Lincoln</b> 2018-2023 Navigator

### Summary

This article supersedes TSB 19-2068 to update the vehicle model years affected.

**Issue:** Some 2018-2023 Navigator and Expedition vehicles may exhibit a concern where the second row seat back does not fold down or recline when the recline handle is pulled upward or the second row single seat easy entry seat fold switch is pressed. This concern may occur with vehicles equipped with two or three second row seats. This may be due to a broken recliner release lever. To correct this concern, replace the recliner release lever.

**Action:** Follow the service procedure to correct the condition on vehicles that meet the following criteria:

- 2018-2023 Expedition/Navigator
- Second row seat back does not fold down or recline

### Parts

Service Part Number	Quantity	Description
LL7Z-99600M46-A	1	Right Outboard Seat Release Lever
LL7Z-99600M47-A	1	Left Outboard Seat Release Lever
LL7Z-99600M47-B	1	Center Seat Release Lever

**Warranty Status:** Eligible under provisions of New Vehicle Limited Warranty (NVLW)/Service Part Warranty (SPW)/Special Service Part (SSP)/Extended Service Plan (ESP) coverage. Limits/policies/prior approvals are not altered by a TSB. NVLW/SPW/SSP/ESP coverage limits are determined by the identified causal part and verified using the OASIS part coverage tool.

### Labor Times

Description	Operation No.	Time
2018-2023 Expedition, Navigator: Replace The Recline Release Lever On One (1) Outer Second Row Seat (Do Not Use With Any Other Labor Operations)	232036A	0.5 Hrs.
2018-2023 Expedition, Navigator: Replace The Recline Release Lever On Both (2) Outer Second Row Seats (Do Not Use With Any Other Labor Operations)	232036B	0.8 Hrs.
2018-2023 Expedition, Navigator: Replace The Recline Release Lever On The Center Second Row Seat (Do Not Use With Any Other Labor Operations)	232036C	0.6 Hrs.
2018-2023 Expedition, Navigator: Replace The Recline Release Lever On One (1) Outer And The Center Second Row Seats (Do Not Use With Any Other Labor Operations)	232036D	0.9 Hrs.
2018-2023 Expedition, Navigator: Replace The Recline Release Lever On Both (2) Outer And The Center Second Row Seats (Do Not Use With Any Other Labor Operations)	232036E	1.2 Hrs.

### Repair/Claim Coding

Causal Part:	99600M47
--------------	----------

Condition Code: 01

## Service Procedure

For vehicles equipped with three second row seats, using a combination of the Outboard Seat Repair Procedure and the Center Seat Repair Procedure in this article may be required.

For vehicles equipped with only two second row seats (captain's chairs) the Outboard Seat Repair Procedure in this article may be required for both seats.

Possible locations for damage on the recline release lever. (Figure 1)

Figure 1

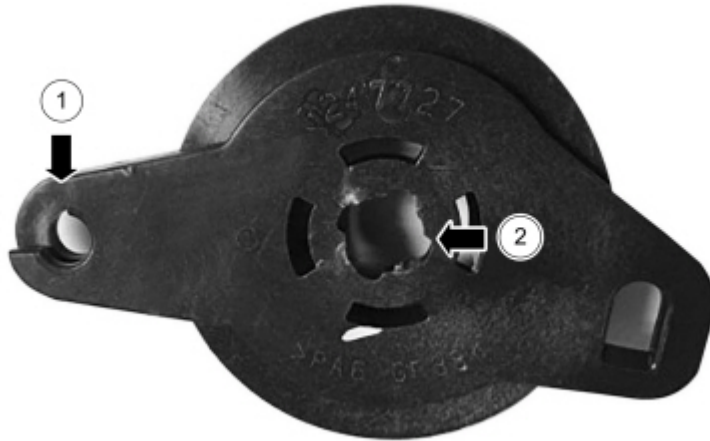

E302645

There are three different recline release levers based on the seat repair. (Figure 2)

Figure 2



E302646

Item	Description
1	Right seat release lever
2	Middle seat release lever
3	Left seat release lever

## Outboard Seat Repair Procedure

1. Move both of the front seats fully forward to allow working space for the second row.
2. If equipped, slide the second row center seat (20%) to the fully rear position.
3. Slide the outboard seat to a position to allow access to both sides of the seat while in the vehicle.
4. Remove the recline handle and trim.
  - (1). Remove the seat recline handle cover. (Figure 3)

Figure 3

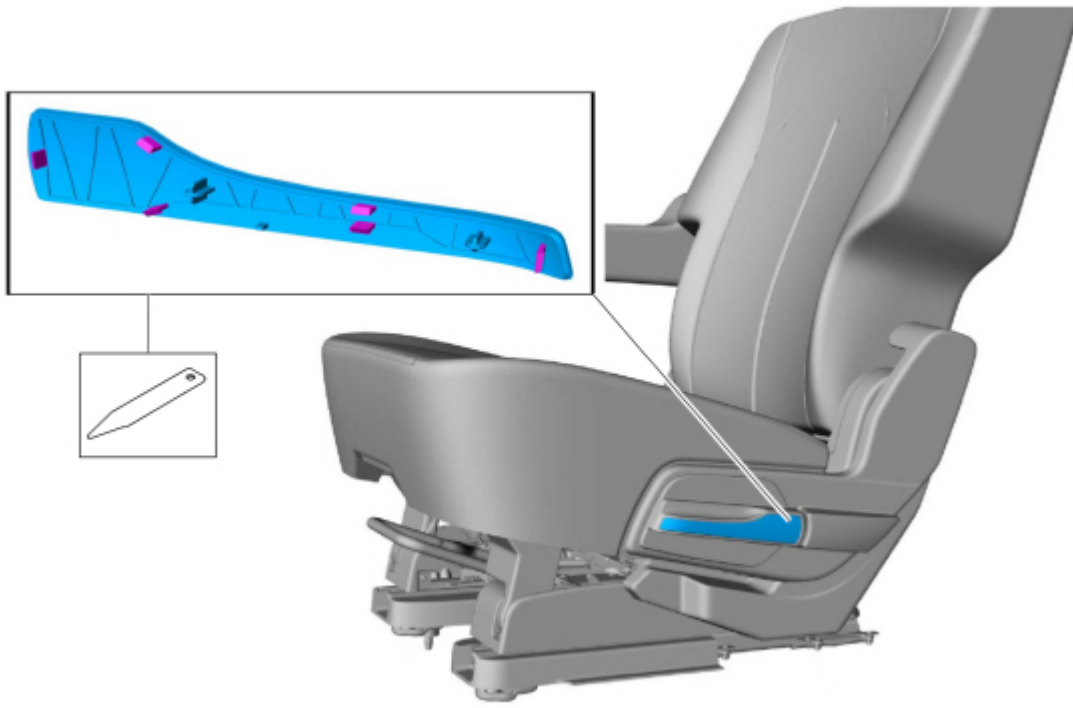

E266241

(2). Remove the recline handle and fastener. (Figure 4)

Figure 4

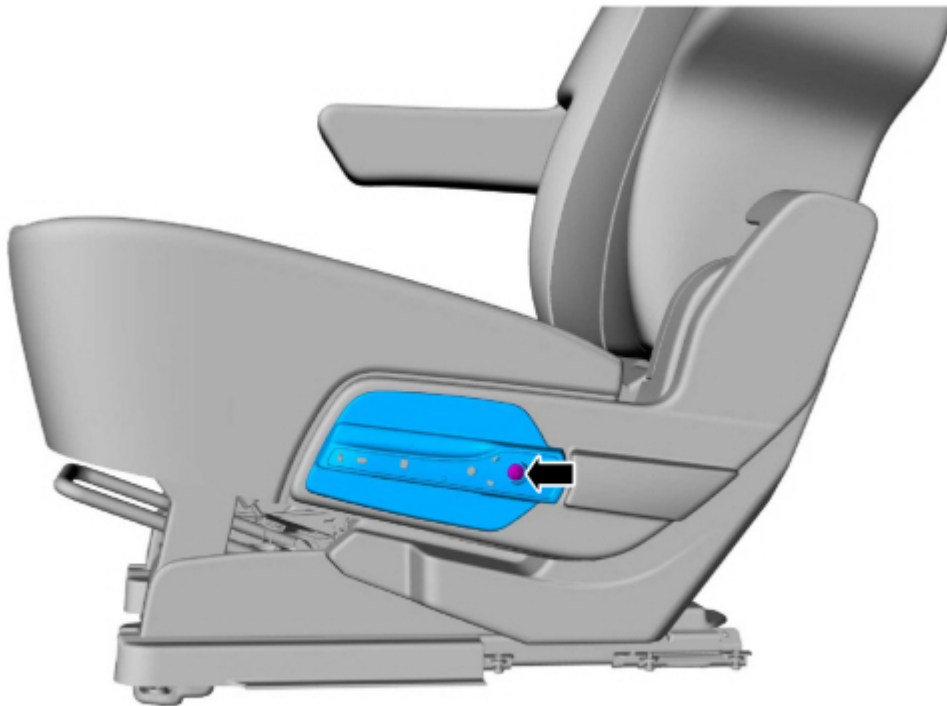

E266242

(3). Remove the seat trim (recline handle side). (Figure 5)

Figure 5

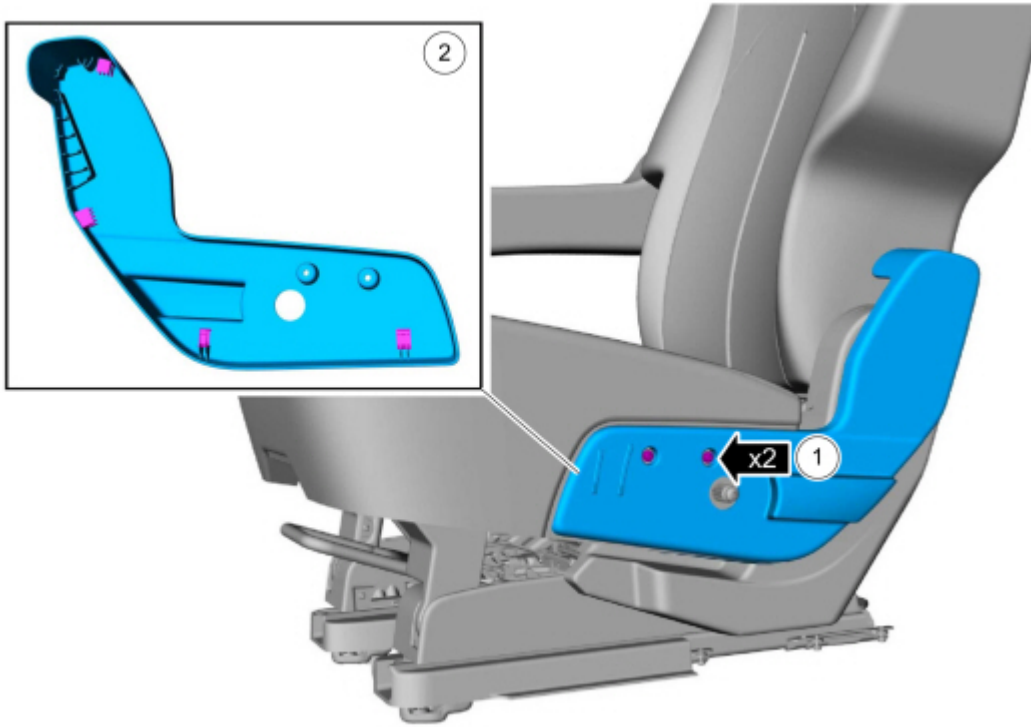

E266243

(4). Remove the seat trim (non-recline handle side). (Figure 6)

Figure 6

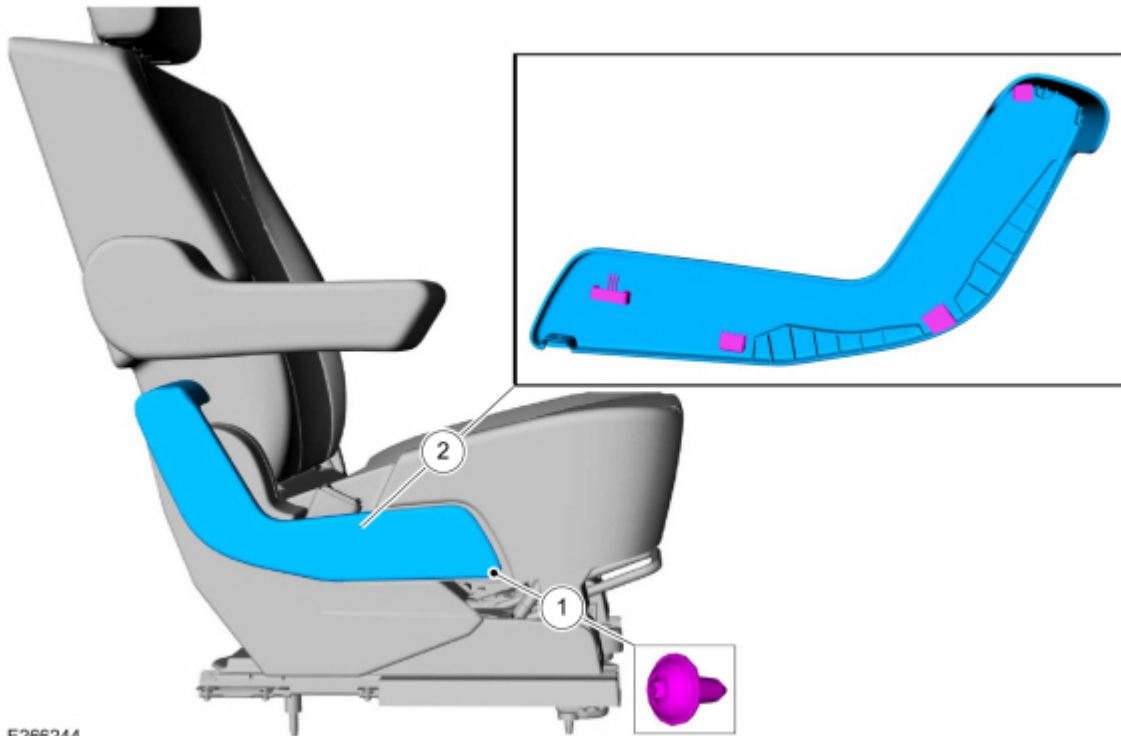

E266244

5. Flip the bottom cushion forward.

(1). With the trim removed on both sides, remove the Torx® head bolt on both sides of the seat. (Figure 7)

Figure 7 - Center seat shown, outboard seat similar



(2). Carefully, without damaging the neighboring seat material, flip the seat cushion forward.

**NOTE: Avoid sliding the seat on the seat track front to back while the seat cushion is flipped forward or damage may result to the neighboring seat trim and material. (Figure 8)**

Figure 8



**6. Access the recline release lever.**

(1). With the bottom seat cushion flipped forward, remove the plastic trim on the recline handle (outboard) side of the seat to access the recline release lever. (Figure 9 Callout 1, Figure 10)

Figure 9

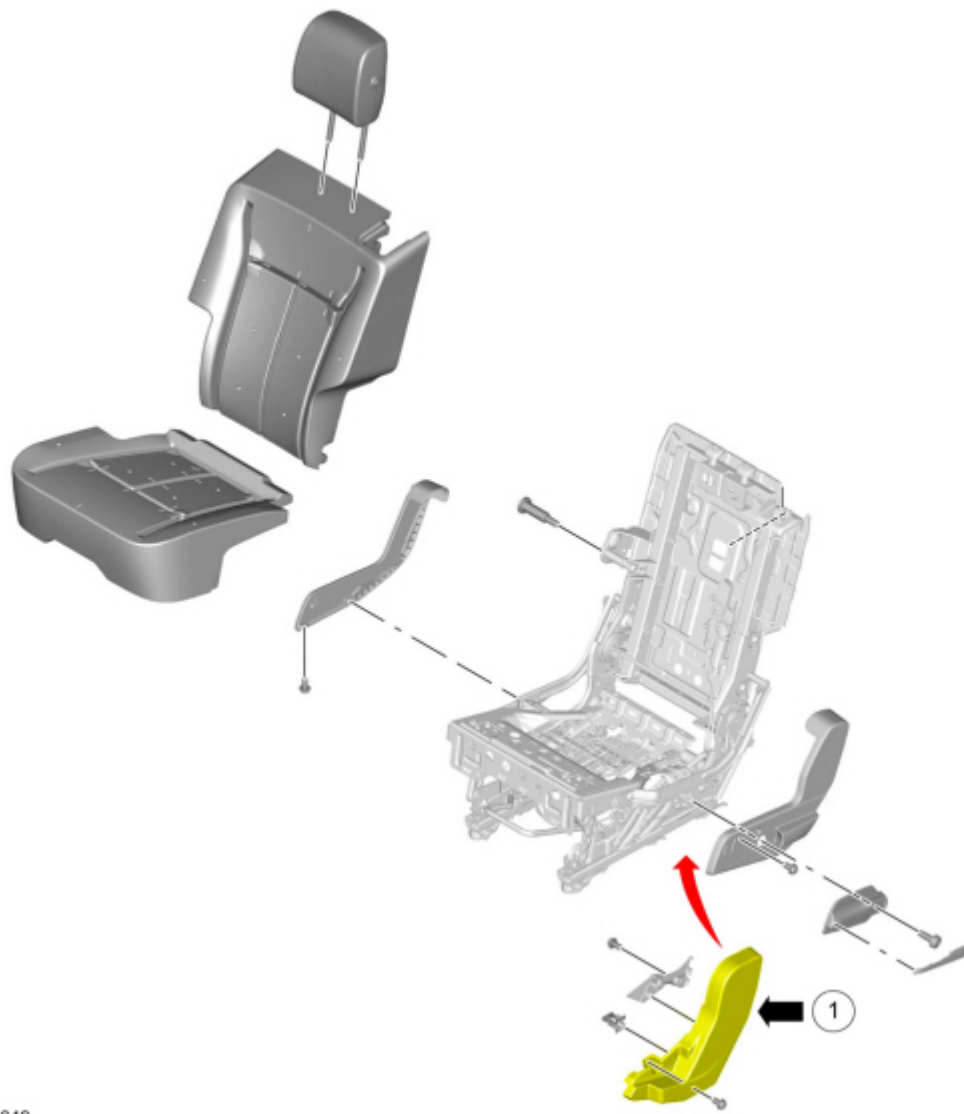

E302649

Figure 10



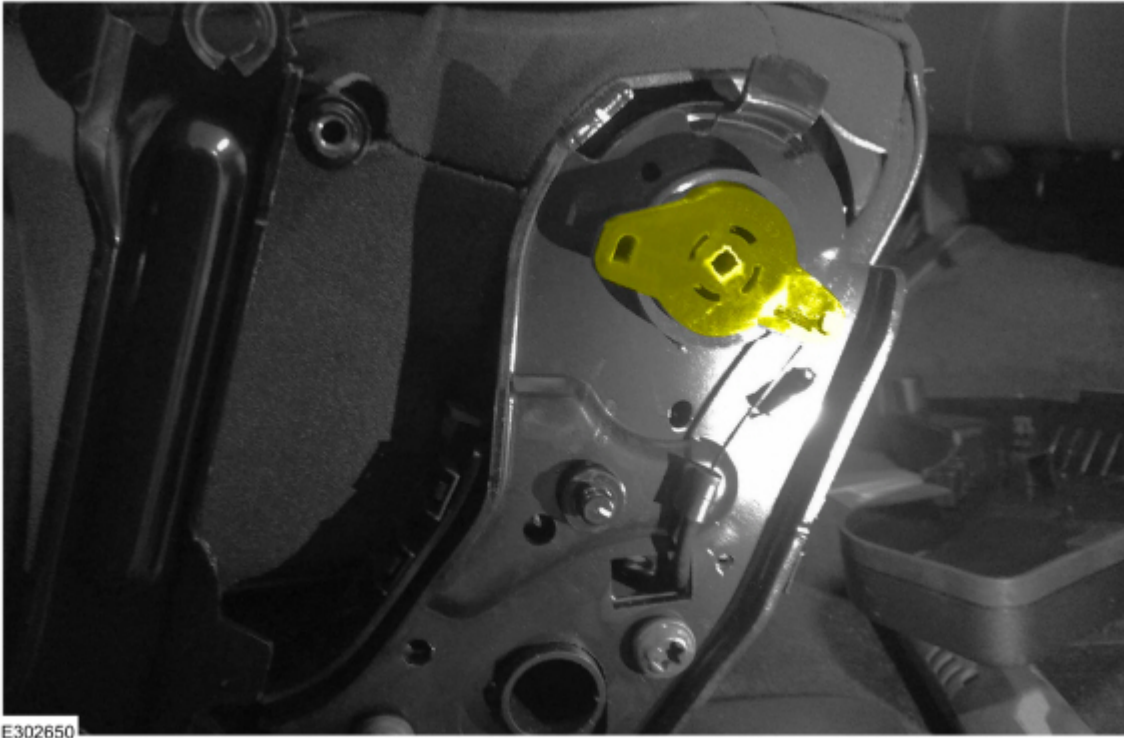

E302650

**7. Remove the damaged recline release lever.**

(1). Carefully unhook the spring and unhook the seat lever cable.

- If either of these attachment points on the recline release lever are damaged, the replacement recline release lever will need both the spring and release cable reattached. (Figures 11-12)

Figure 11



E302651

Figure 12

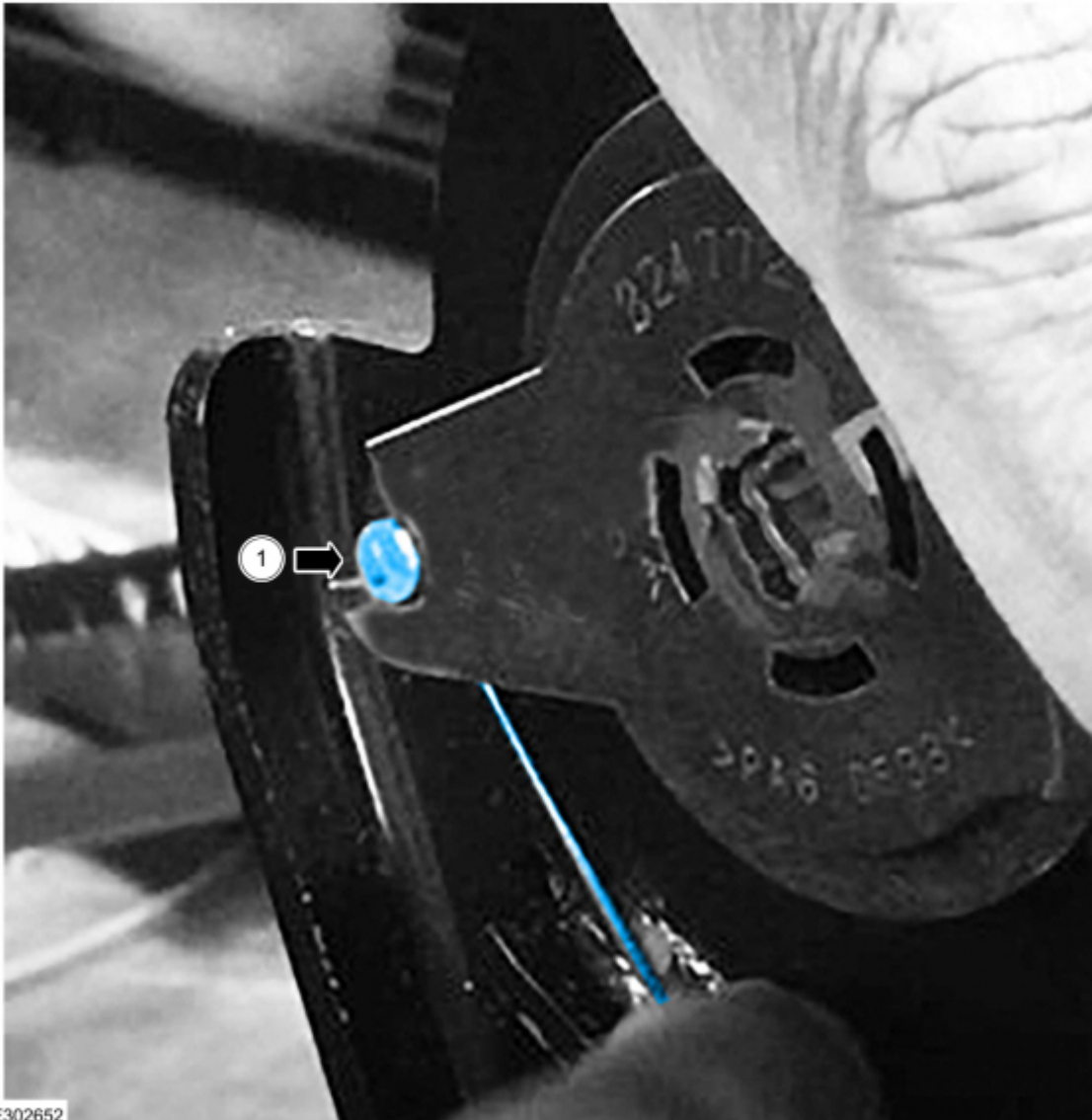

E302652

(2). Once both the spring and release cable are free of the recline release lever, gently pry on the backside of the recline release lever to remove it.

**NOTE: When prying on the backside of the recline release lever, be careful not to remove the inner mounting ring. If the inner mounting ring is removed, seat assembly replacement is required. (Figures 13-14)**

Figure 13



E302653

Figure 14

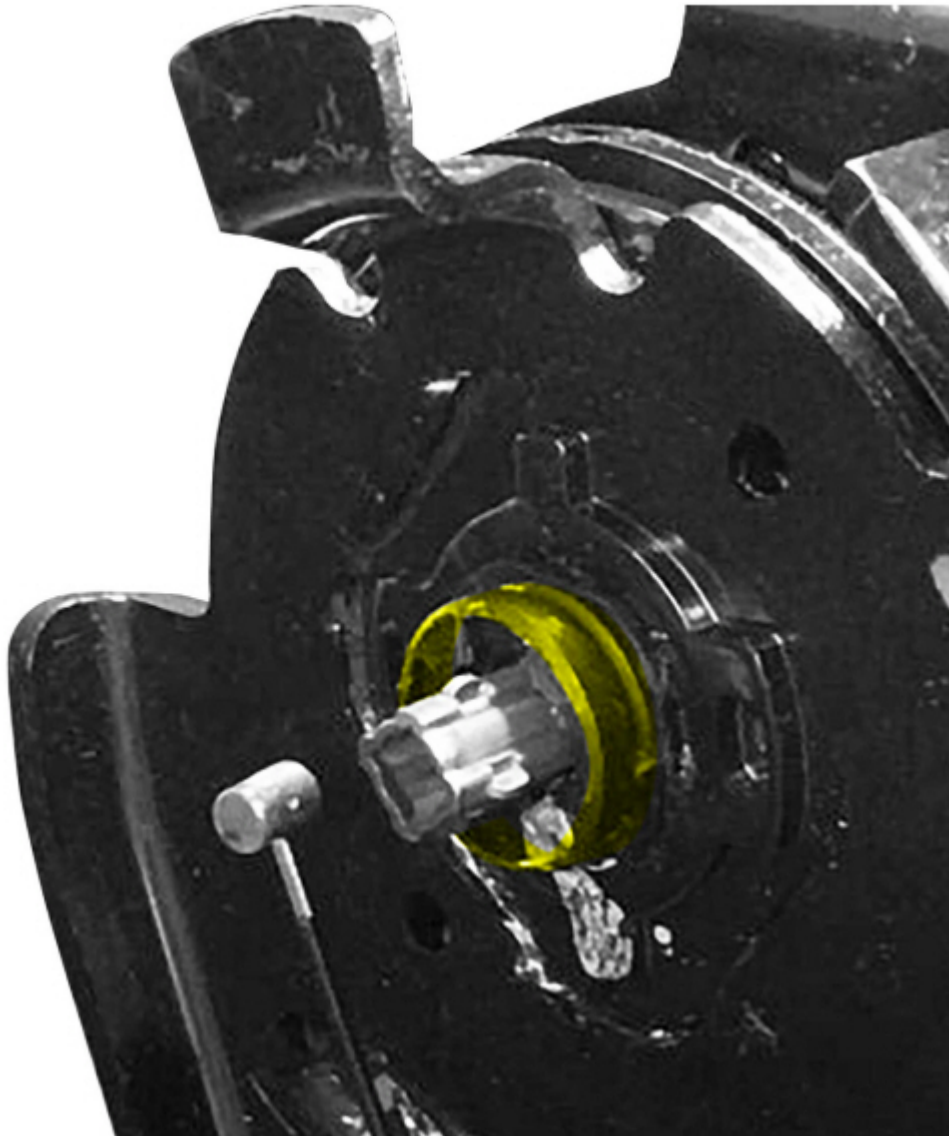

E302654

**8. Install the new recline release lever.**

- (1). Install the new recline release lever by pressing the new part into place.

**NOTE: The square tube that holds the recline release lever in place may need to be pulled out to seat the new part. Do not pull the tube more than a few millimeters as this tube runs the entire length of the chair. Pulling out too far will unseat the opposite side of the chair and will require seat assembly replacement. (Figures 15-16)**

Figure 15



E302655

Figure 16



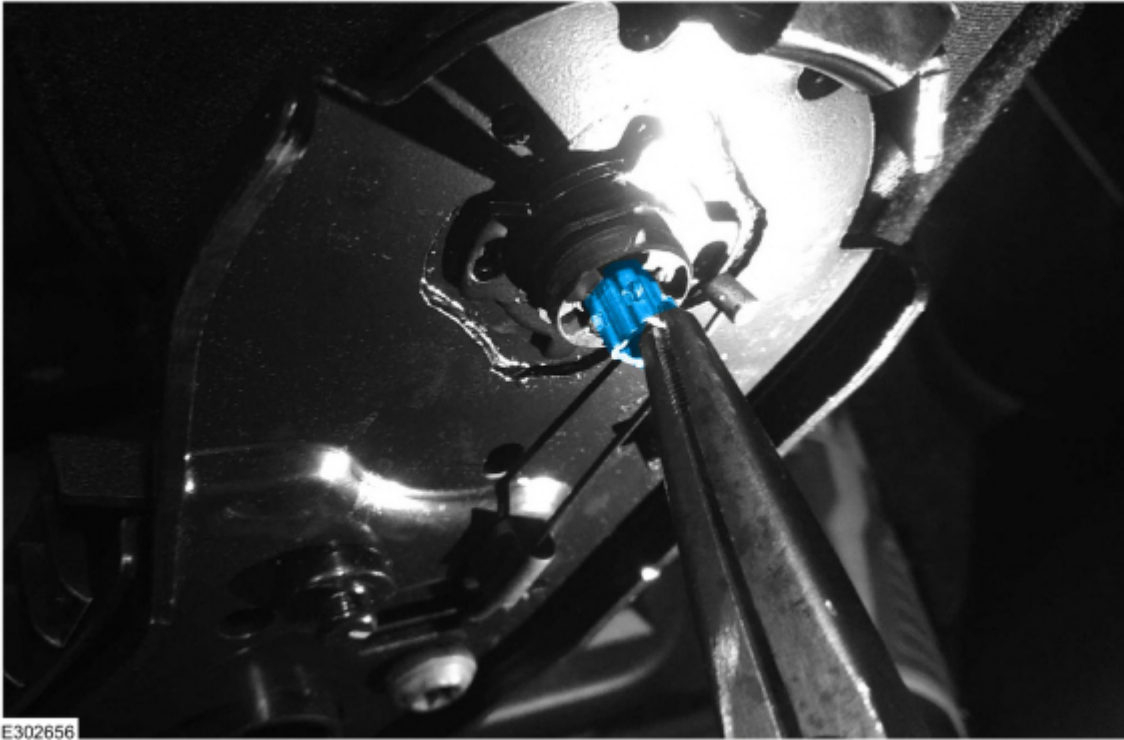

**9.** Once the new recline release lever is installed, connect the seat recline cable and the spring back into place on each side of the recline release lever. (Figures 17-18)

Figure 17

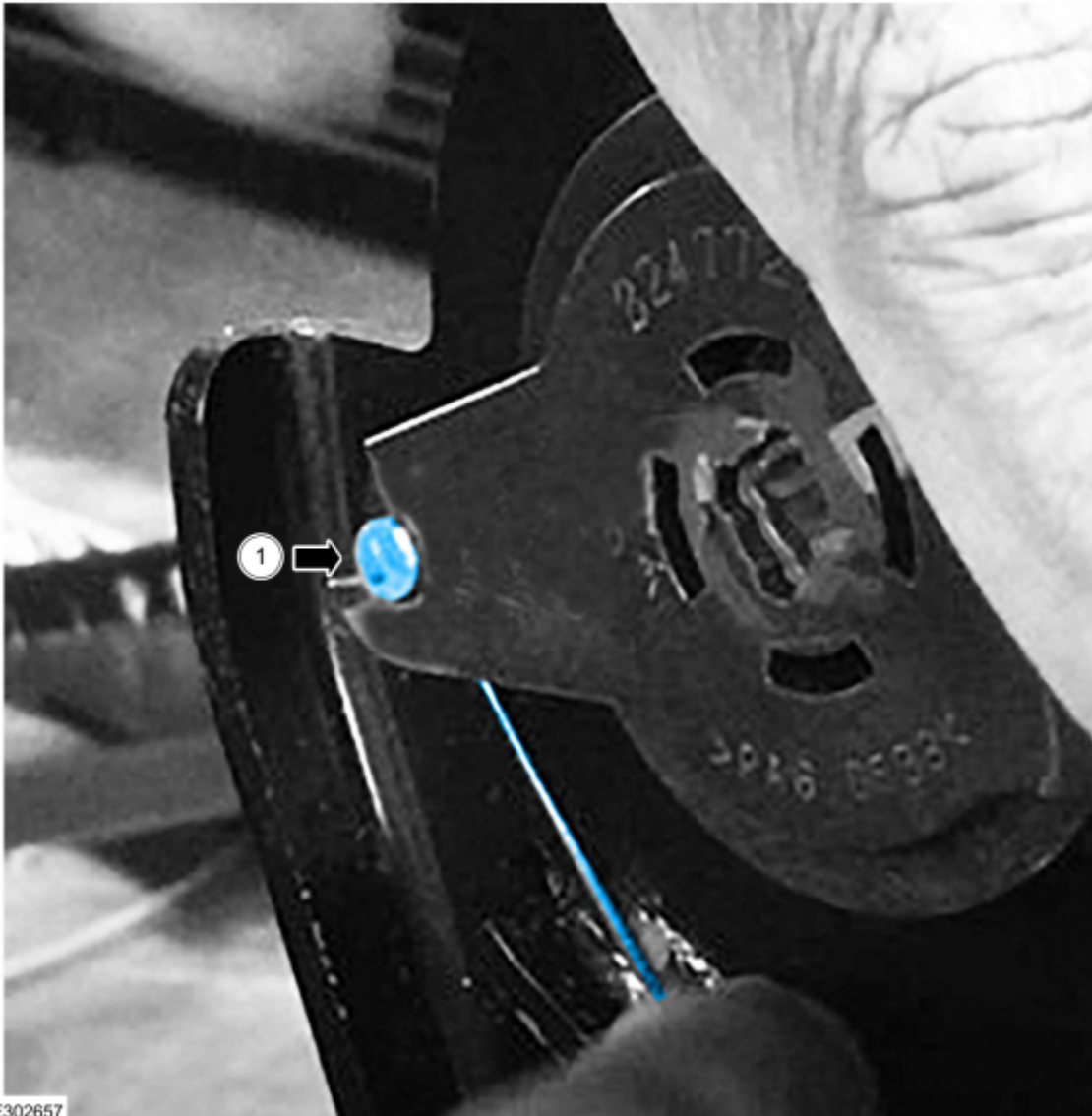

E302657

Figure 18



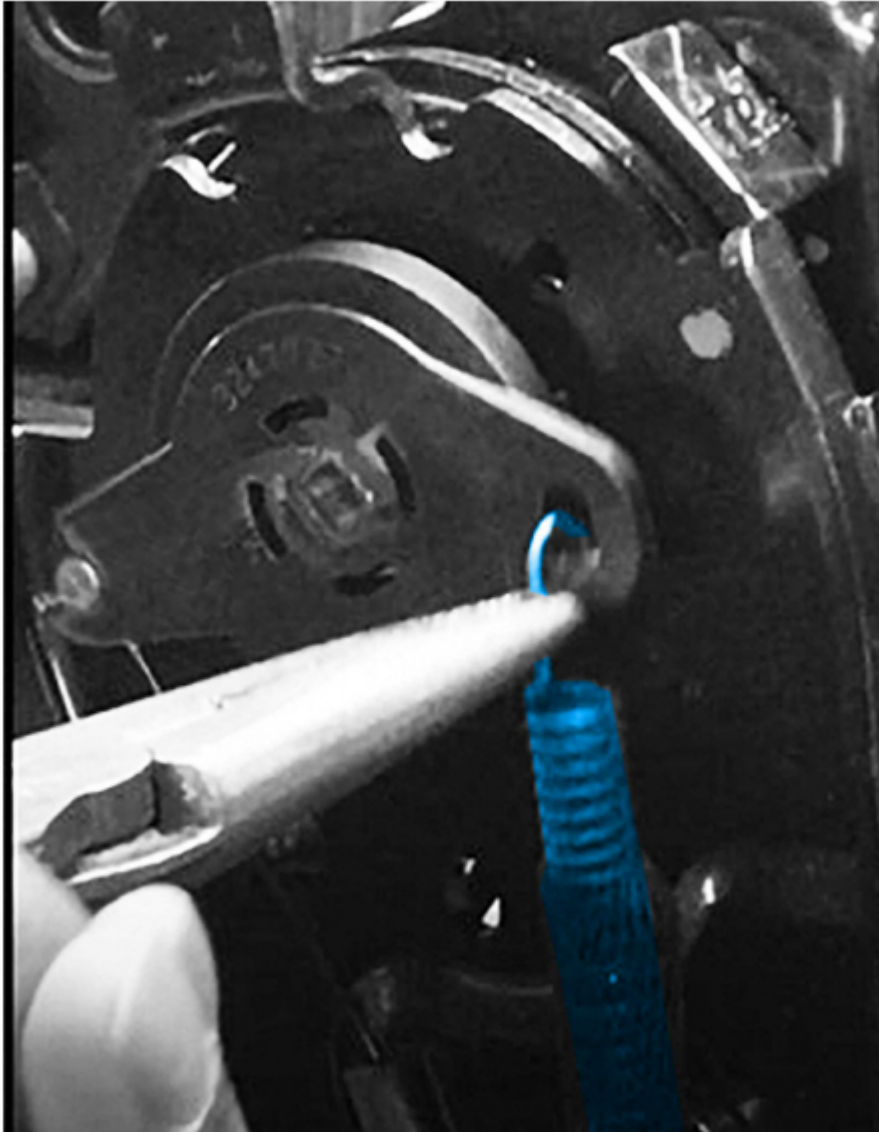

E302658

10. To install the plastic trim, seat bottom and recline handle, reverse the removal procedure.

### **Center Seat Repair Procedure**

1. Move both of the front seats fully forward to allow working space for the second row.
2. Position the center seat and neighboring outboard seats to allow access to both sides of the center seat to remove the center seat trim.
3. Lift the rear seat accordion fabric to allow access to the seat trim. (Figure 19)

Figure 19

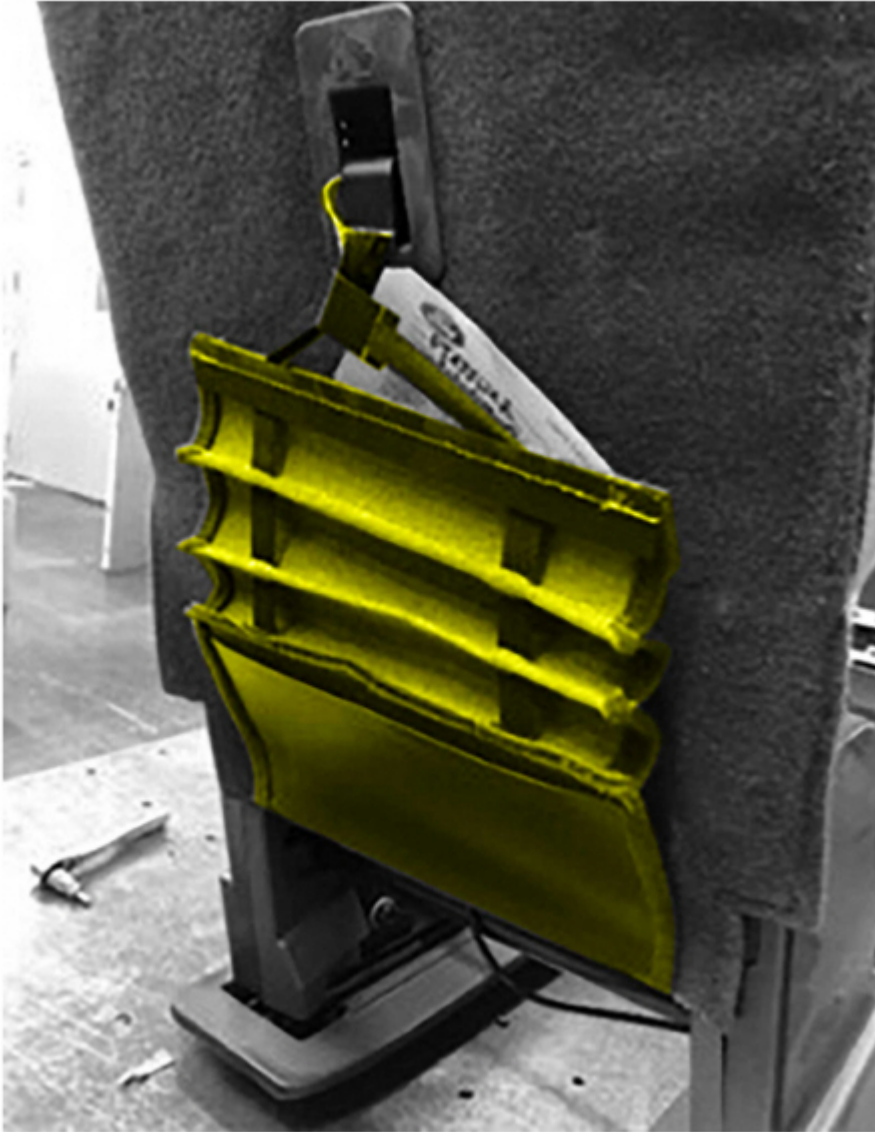

E302659

**4. Remove the seat trim.**

(1). Remove both trim pieces on the outside of the center chair. (Figure 20 Callouts 1-2, Figure 21)

Figure 20

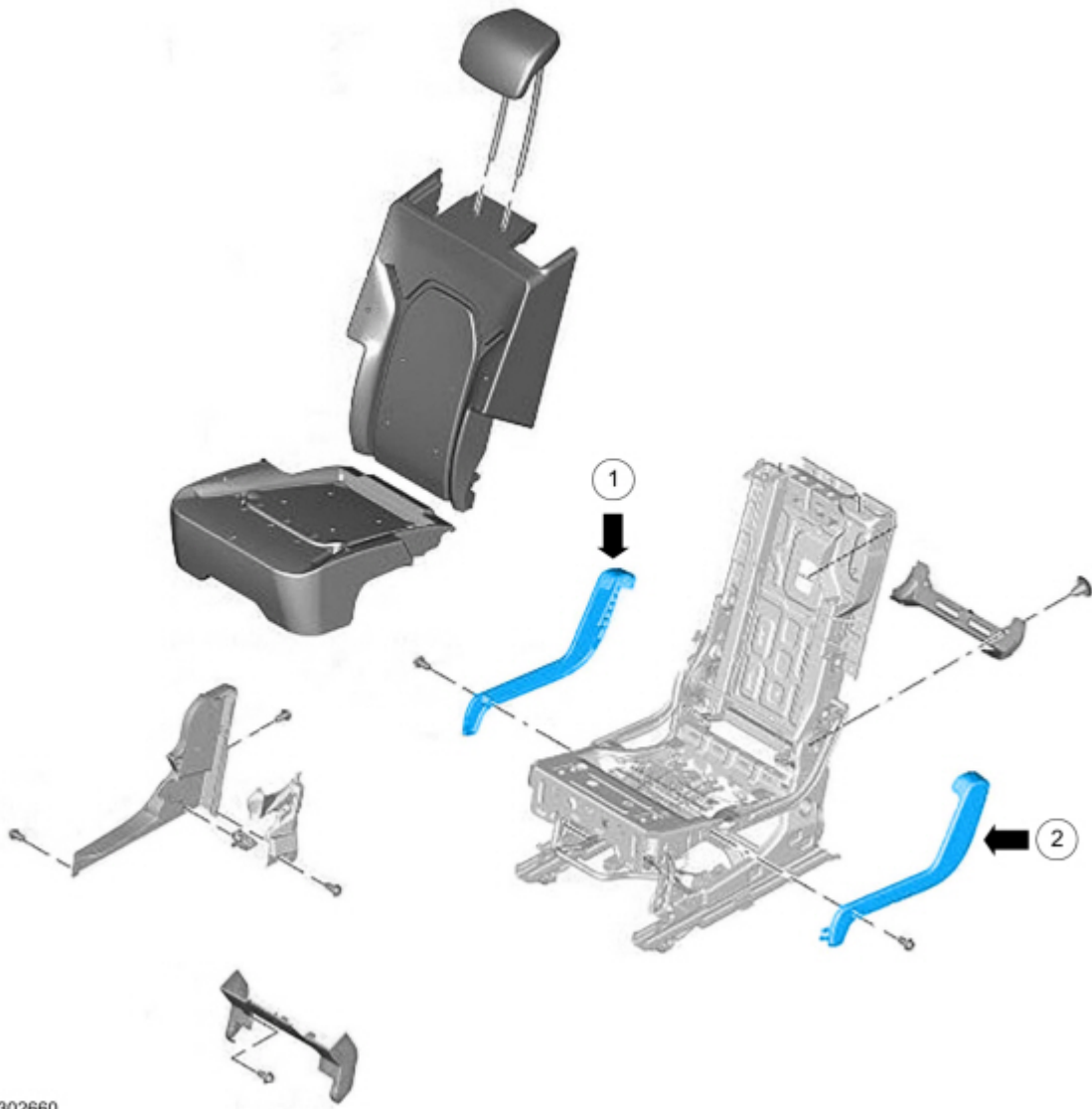

E302660

Figure 21



E302661

**5. Flip the bottom cushion forward.**

- (1). With the trim removed on both sides of the center seat, remove the Torx® head bolt on both sides of the seat. (Figure 7)
- (2). Carefully, without damaging the neighboring seat material, flip the seat cushion forward on both ends.

**NOTE: Avoid sliding the seat front to back while the seat cushion is flipped forward or damage can occur to the neighboring seat. (Figure 8)**

**6. Access the recline release lever.**

- (1). With the bottom seat cushion flipped forward, remove the plastic trim on the right side of the seat to access the recline release lever.
- (2). There are screws on the backside of the center seat trim that need to be removed. (Figure 22 Callout 3, Figures 23, 24, 10)

Figure 22



E302662

Figure 23

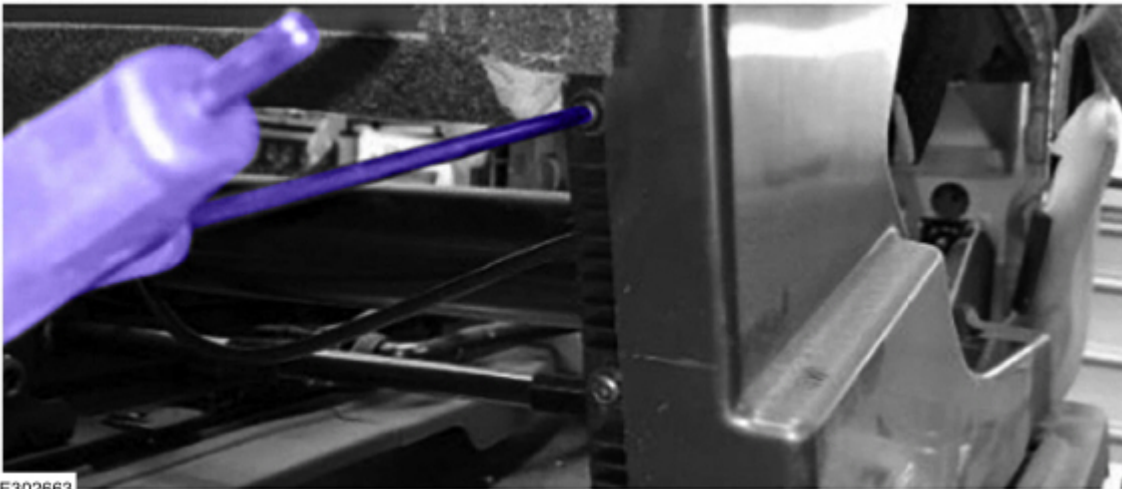

E302663

Figure 24

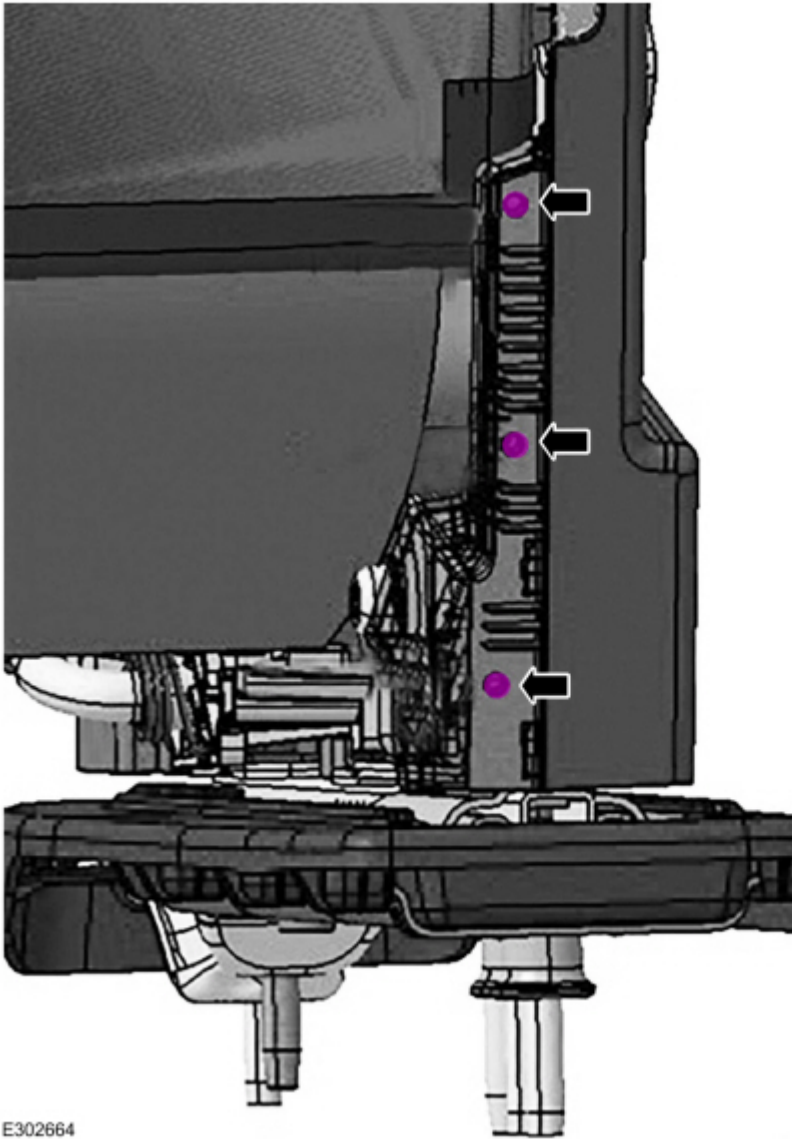

E302664

**7. Remove the damaged recline release lever.**

(1). Carefully unhook the spring and unhook the seat lever cable.

- If either of these attachment points on the recline release lever are damaged and the spring or seat lever cable are detached, the replacement recline release lever will need both the spring and release cable reattached. (Figures 11-12)

(2). Once both the spring and release cable are free of the recline release lever, gently pry on the backside of the recline release lever to remove it.

**NOTE: When prying on the backside of the recline release lever, be careful not to remove the inner mounting ring. If the inner mounting ring is removed, seat assembly replacement is required. (Figures 13-14)**

**8. Install the new recline release lever.**

(1). Install the new recline release lever by pressing the new part into place.

**NOTE: The square tube that holds the recline release lever in place may need to be pulled out to seat the new part. Do not pull the tube more than a few millimeters as this tube runs the entire length of the chair. Pulling out too far will unseat the opposite side of the chair and will require seat assembly replacement. (Figures 15-16)**

**9. Once the new recline release lever is installed, connect the seat recline cable and the spring back into place on each side of the recline release lever. (Figures 17-18)**

**10. To install the plastic trim and seat bottom back, reverse the removal procedure.**



NOTE: The information in Technical Service Bulletins is intended for use by trained, professional technicians with the knowledge, tools, and equipment to do the job properly and safely. It informs these technicians of conditions that may occur on some vehicles, or provides information that could assist in proper vehicle service. The procedures should not be performed by "do-it-yourselfers". Do not assume that a condition described affects your car or truck. Contact a Ford or Lincoln dealership to determine whether the Bulletin applies to your vehicle. Warranty Policy and Extended Service Plan documentation determine Warranty and/or Extended Service Plan coverage unless stated otherwise in the TSB article. The information in this Technical Service Bulletin (TSB) was current at the time of printing. Ford Motor Company reserves the right to supersede this information with updates. The most recent information is available through Ford Motor Company's on-line technical resources.