



TECHNICAL SERVICE BULLETIN

Level 3 Charging - Illuminated Charger Service Required Indicator In The IPC And/Or Multiple DTCs

22-2355

19 September
2022

Model:

Ford
2022 e-Transit
2022 F-150 Lightning
2021-2022 Mustang Mach-E

Issue: Some 2021-2022 Mustang Mach-E, 2022 e-Transit and F-150 Lightning vehicles may experience inoperative level 3 charging with an illuminated Charger Service Required indicator in the instrument panel cluster (IPC) and diagnostic trouble codes (DTCs) P0D93:00, P0D94:00, P0D98:00, P0D9E:00 and/or P0DA0:00 in the secondary on-board diagnostic module (SOBDM). If the charging cord is removed from the charge port without the lock/release button fully depressed, this can damage the charge port locking pin actuator and disable level 3 charging for the next charging session. To correct the condition, follow the Service Procedure to replace only the charge port lock actuator.

Action: Follow the Service Procedure to correct the condition if the vehicle meets the following criteria:

- One of the following vehicles:
 - 2021-2022 Mustang Mach-E
 - 2022 e-Transit
 - 2022 F-150 Lightning
- Level 3 charging inoperative
- Illuminated Charger Service Required indicator
- Charge port lock actuator pin broken and/or missing
- At least one of the following DTCs:
 - P0D93:00
 - P0D94:00
 - P0D98:00
 - P0D9E:00
 - P0DA0:00

Parts

Service Part Number	Quantity	Description
LJ9Z-10D737-A	1	Actuator Assembly

Warranty Status: Eligible under provisions of New Vehicle Limited Warranty (NVLW)/Service Part Warranty (SPW)/Special Service Part (SSP)/Extended Service Plan (ESP) coverage. Limits/policies/prior approvals are not altered by a TSB. NVLW/SPW/SSP/ESP coverage limits are determined by the identified causal part and verified using the OASIS part coverage tool.

Labor Times

Description	Operation No.	Time
2022 e-Transit: Inspect And Replace Actuator Following The Service Procedure (Can Be Used With Operation D) (Do Not Use With Any Other Labor Operations Outside Of This Article)	222355A	1.7 Hrs.
2022 F-150 Lightning: Inspect And Replace Actuator Following The Service Procedure (Do Not Use With Any Other Labor Operations)	222355B	1.2 Hrs.

2021-2022 Mustang Mach-E: Inspect And Replace Actuator Following The Service Procedure (Do Not Use With Any Other Labor Operations)	222355C	1.5 Hrs.
2022 e-Transit: Additional Time To Perform 360 Degree Camera Alignment (Can Be Use With Operation A)	222355D	0.7 Hrs.

Repair/Claim Coding

Causal Part:	10D737
Condition Code:	01

Service Procedure

NOTE: To prevent repeat concerns with the charge port lock actuator, fully depress the charge port lock/release button before disconnecting the charge cord. (Figure 1) The charge port lock actuator may also be released by utilizing the vehicle's center display screen menu or depressing the release button located on the level 3 direct current (DC) fast charger.

Figure 1



E391533

- For Mach-E vehicles, refer to the Digital Owner's Manual located in the vehicle's center display screen by selecting Features > Owner's Manual > Charging Your Vehicle > DC Charging > Stopping Charging.
- For e-Transit vehicles, refer to the Digital Owner's Manual located in the vehicle's center display screen by selecting Features > Owner's Manual > Charging Your Vehicle - Electric Motor > DC Charging > Stopping Charging.

- For F-150 Lightning vehicles, refer to the Lightning Digital Owner's Manual located in the vehicle's center display screen by selecting Features > Owner's Manual > Charging Your Vehicle > DC Charging > Stopping Charging.

1. Inspect the charge port lock actuator pin. (Figure 2) Is the charge port lock actuator pin missing or loose?

Figure 2



E391534

- (1). Yes - proceed to Step 2.
 - (2). No - this article does not apply. Refer to Workshop Manual (WSM), Section 414-03B High Voltage Battery Charging System.
2. De-energize the high voltage system. Refer to WSM, Section 414-03A High Voltage Battery > Mounting and Cable > General Procedures.
3. Gain access to the charging port.
- (1). For e-Transit vehicles, remove the front bumper cover. Refer to WSM, Section 501-19 Front Bumper Cover > Bumpers > Disassembly and Assembly.
 - Remove the retainers and the charge port cover. (Figure 3)

Figure 3

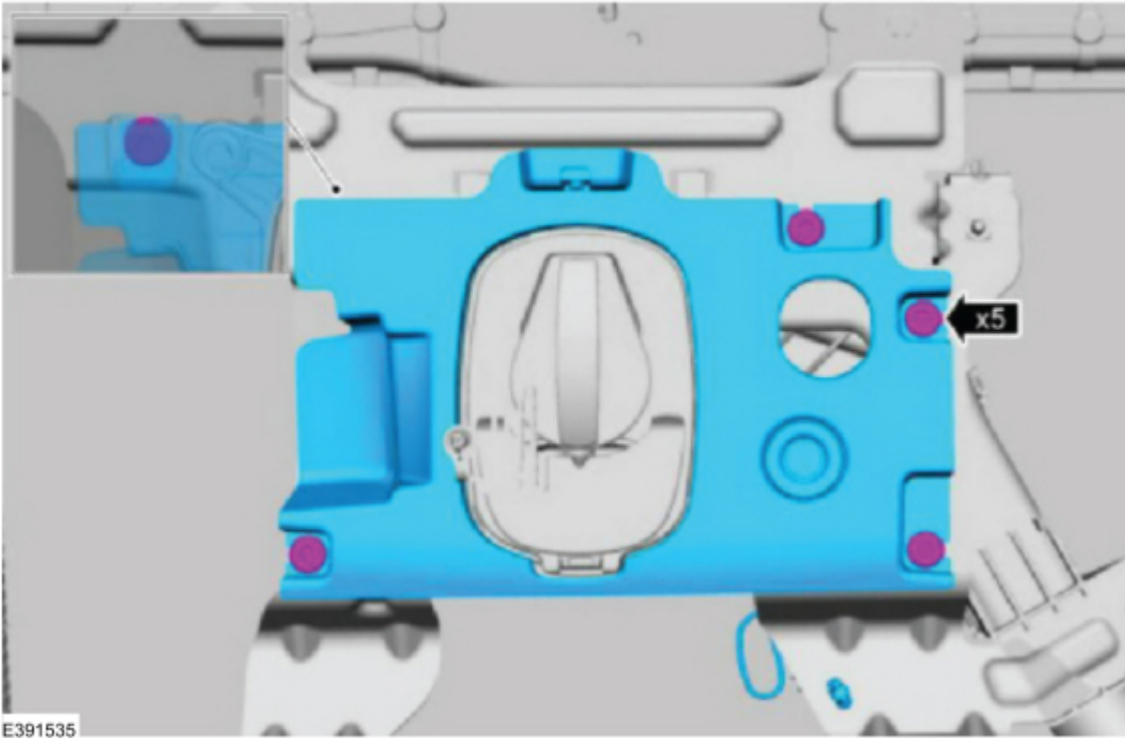

(2). For Mustang Mach-E and F-150 Lightning vehicles, remove the following components:

- Left front wheel. Refer to WSM, Section 204-04A Wheels and Tires.
- Fender splash shield. Refer to WSM, Section 501-02 Front End Body Panels > Removal and Installation.
- Charge status indicator (CSI) housing assembly. Refer to WSM, Section 414-03B High Voltage Battery Charging System > Removal and Installation.

4. Disconnect the charge cord lock release cable and 4-way electrical connector to the lock actuator. (Figure 4)

Figure 4

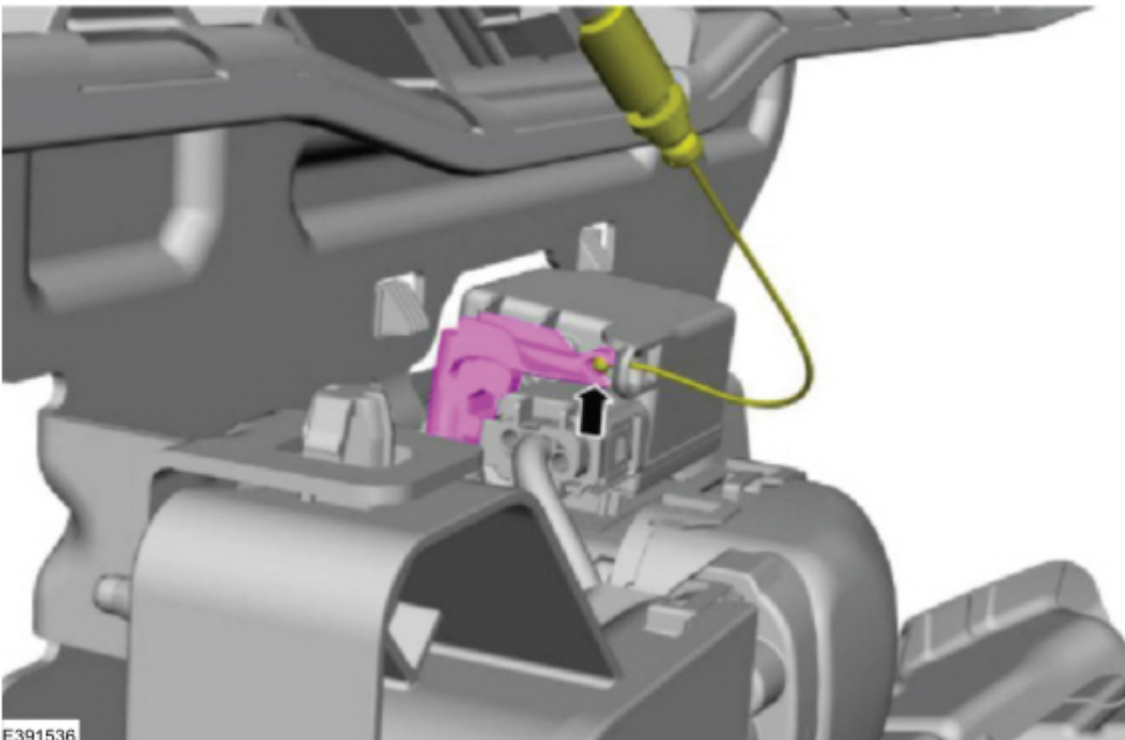

5. Remove the 4 bolts holding the charge port to the body bracket. (Figure 5)

Figure 5

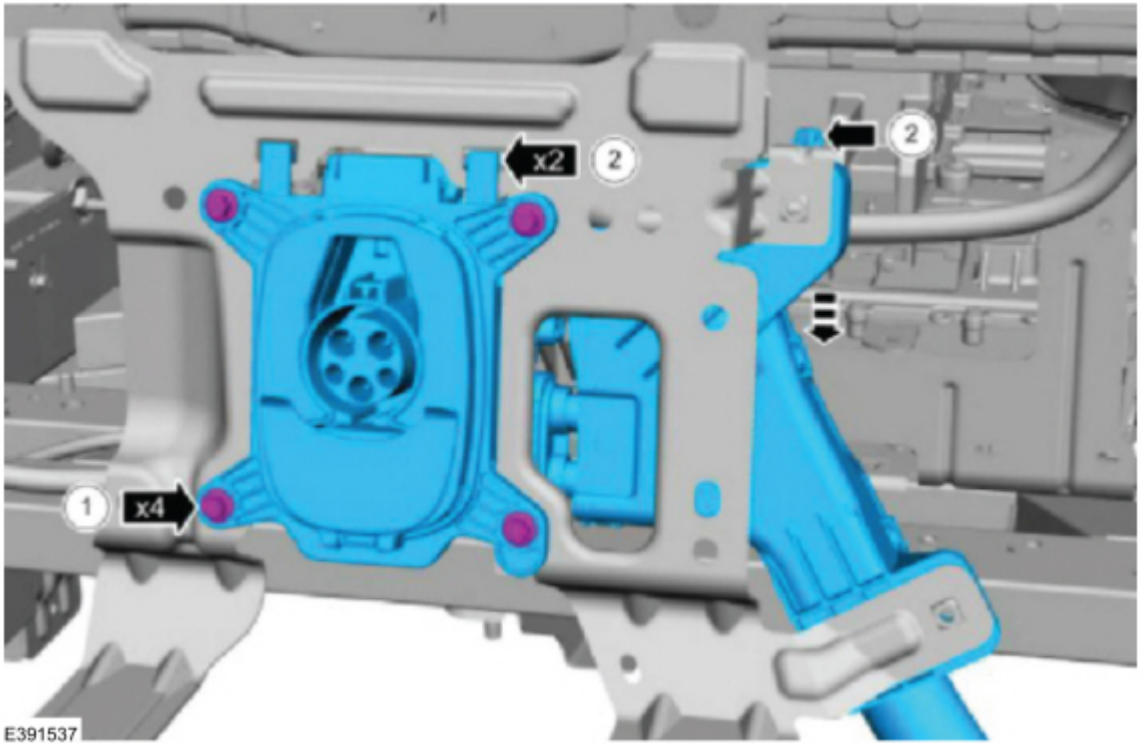

6. Release the 2 snap features and slide the charge port downward along the guide track until there is enough space to remove 2 actuator bolts and the actuator. (Figure 6)

Figure 6

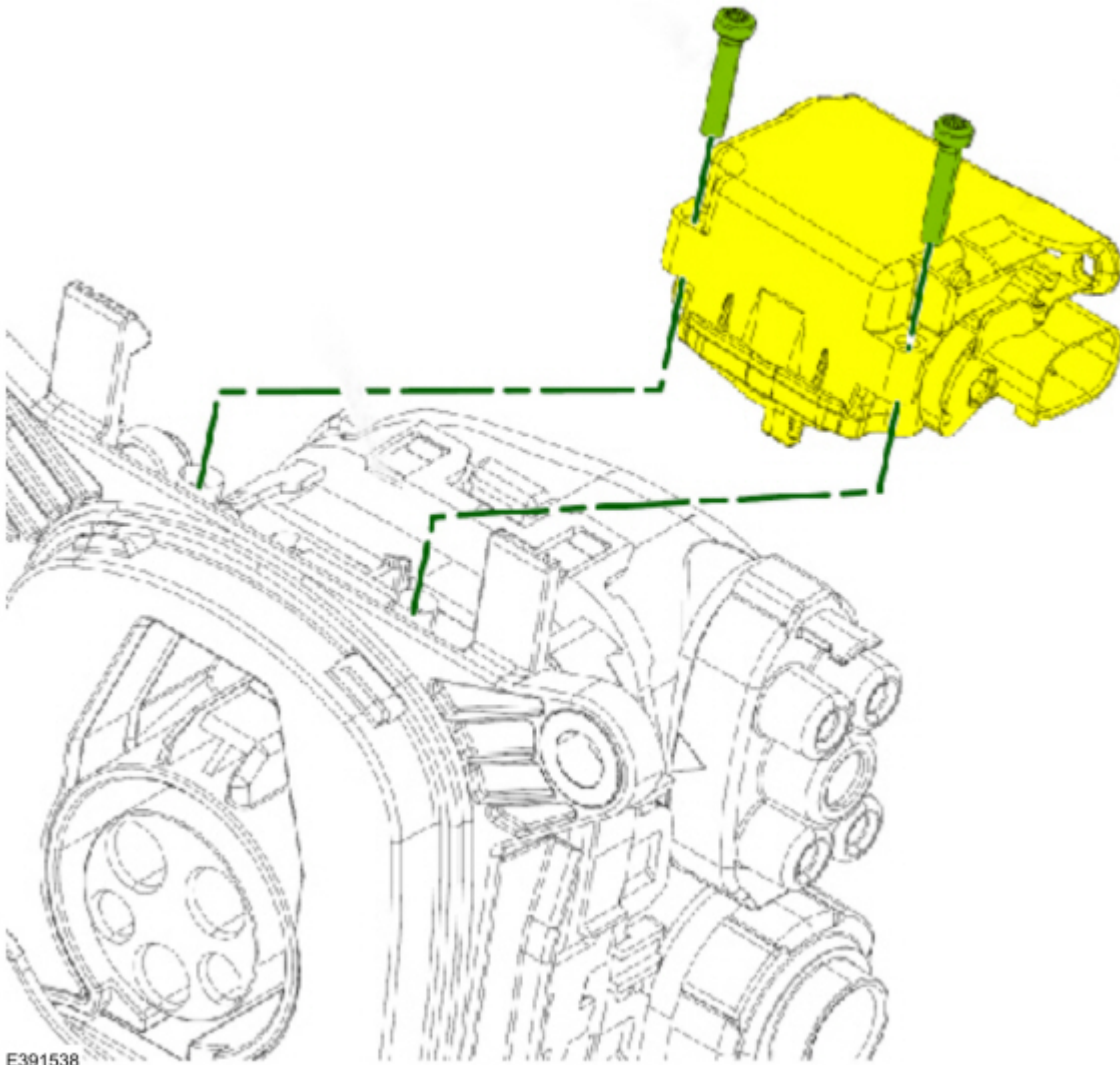

E391538

7. Install a new actuator and 2 new actuator bolts. Tighten to 1.2 nm (10.6 lb-in).
8. Align the charge port guides with the bracket and slide back up into position until snap features engage and holds the part in place with all four holes lined up.
9. Reuse the 4 charge port bolts. Tighten to 10.5 nm (93 lb-in).
10. Install the charge cord lock release cable and 4-way electrical connector to the lock actuator. (Figure 4)
11. Install the accessibility components.
 - (1). For e-Transit vehicles, install the retainers and the charge port cover. (Figure 3)
 - Reinstall the front bumper cover. Refer to WSM, Section 501-19 Front Bumper Cover > Bumpers > Disassembly and Assembly.
 - (2). For Mustang Mach-E and F-150 Lightning vehicles, install the following components:
 - Left front wheel. Refer to WSM, Section 204-04A Wheels and Tires.
 - Fender splash shield. Refer to WSM, Section 501-02 Front End Body Panels > Removal and Installation.
 - CSI housing assembly. Refer to WSM, Section 414-03B High Voltage Battery Charging System > Removal and Installation.

described affects your car or truck. Contact a Ford or Lincoln dealership to determine whether the Bulletin applies to your vehicle. Warranty Policy and Extended Service Plan documentation determine Warranty and/or Extended Service Plan coverage unless stated otherwise in the TSB article. The information in this Technical Service Bulletin (TSB) was current at the time of printing. Ford Motor Company reserves the right to supersede this information with updates. The most recent information is available through Ford Motor Company's on-line technical resources.