



## TECHNICAL SERVICE BULLETIN

### Moan Noise In The Rear Brakes When Vehicle Is Driven In Reverse On Cold Weather And/Or High Humidity

22-2326

17 August 2022

#### Model:

<b>Ford</b>
2021-2022 Bronco Sport
2020-2022 Escape

**Issue:** Some 2020-2022 Escape and 2022 Bronco Sport vehicles may exhibit a moan noise when the vehicle is driven in reverse (R) in cold weather and/or high humidity. This may be due to the suspension sensitivity of the vehicle. To correct this condition, follow the Service Procedure to replace the rear caliper bushings.

**Action:** Follow the Service Procedure to correct the condition on vehicles that meet all the following criteria:

- One of the following vehicles:
  - 2020-2022 Escape
  - 2021-2022 Bronco Sport
- Moan noise when the vehicle is driven in reverse on cold weather and/or high humidity

#### Parts

Service Part Number	Quantity	Description	Unit of Issue	Piece Quantity	Note
DG9Z-2C150-B	2	Rear Reinforced Bushing Kit	1 Kit	1 Kit Per Caliper	Kit contains: 2 guide pins, 2 guide pin caps, 1 standard bushing 1 reinforced bushing
XG-3-A	As Needed	Motorcraft® Silicone Brake Caliper Grease and Dielectric Compound			
PM-4-A	As Needed	Motorcraft® Metal Brake Parts Cleaner (Compliant With Low Volatile Organic Compound Requirements As Required In Some USA States)			
PM-4-B	As Needed	Motorcraft® Metal Brake Parts Cleaner (Not Compliant With Volatile Organic Compound Requirements)			

**Warranty Status:** Eligible under provisions of New Vehicle Limited Warranty (NVLW)/Service Part Warranty (SPW)/Special Service Part (SSP)/Extended Service Plan (ESP) coverage. Limits/policies/prior approvals are not altered by a TSB. NVLW/SPW/SSP/ESP coverage limits are determined by the identified causal part and verified using the OASIS part coverage tool.

#### Labor Times

Description	Operation No.	Time
2020-2022 Escape, 2021-2022 Bronco Sport: Replace The Caliper Bushing On Both (2) Rear Brake Calipers Following The Service Procedure (Do Not Use With Any Other Labor Operations)	222326A	0.7 Hrs.

#### Repair/Claim Coding

Causal Part:	2C150
Condition Code:	42

#### Service Procedure

##### Bronco Sport



##### Escape

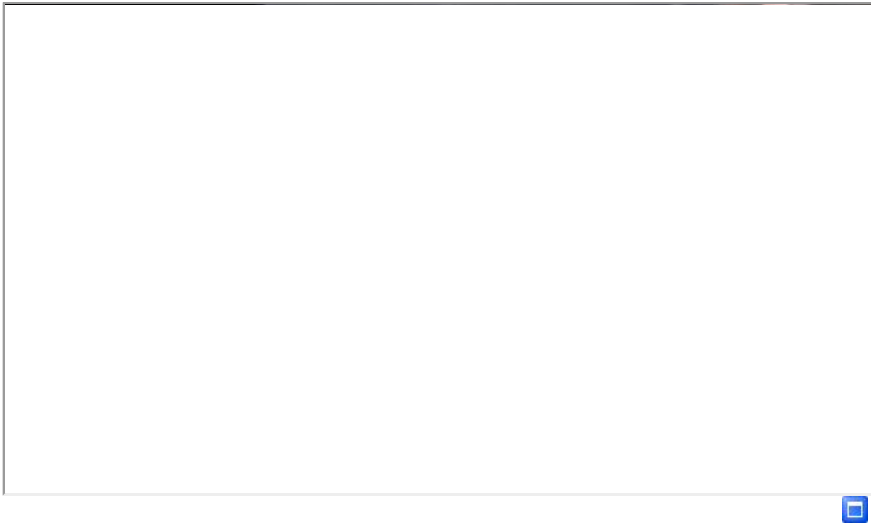

**NOTE: Perform this procedure on both rear calipers.**

1. Activate the brake service mode. Refer to the Workshop Manual (WSM), Section 206-00 Brake System > General Information > General Procedures.
2. Remove the wheel and tire. Refer to the WSM, Section 204-04A Wheels and Tires > Removal and Installation.
3. Remove the brake caliper spring. (Figure 1)

Figure 1

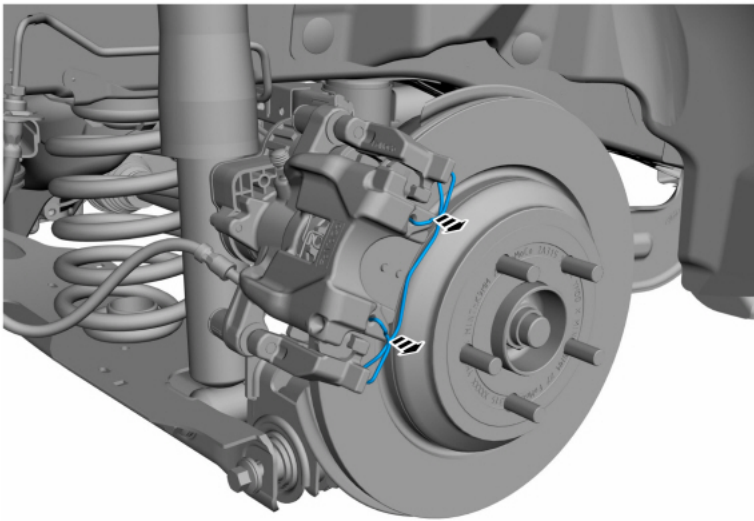

E312184

4. Disconnect the parking brake electrical connector. (Figure 2)

Figure 2

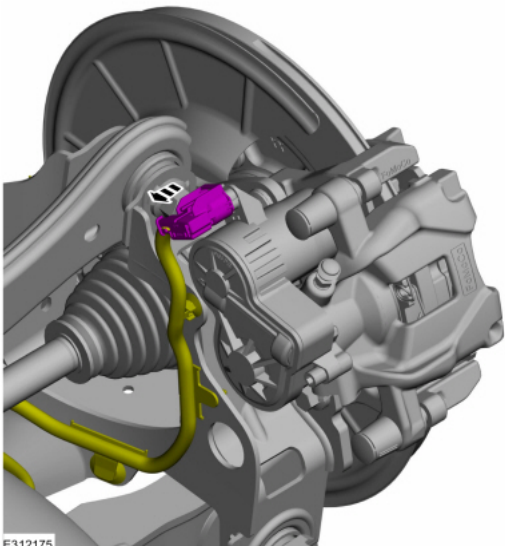

E312175

5. Remove and discard the brake caliper guide pin cap and guide pin on the opposite side of the bleeder. (Figures 3-5)

Figure 3

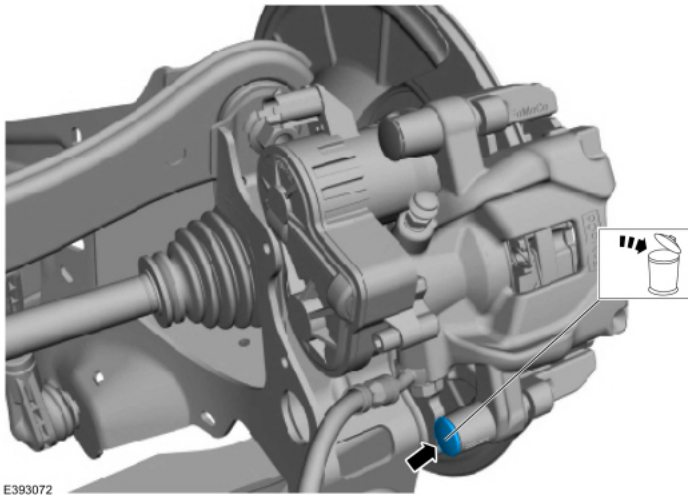

Figure 4

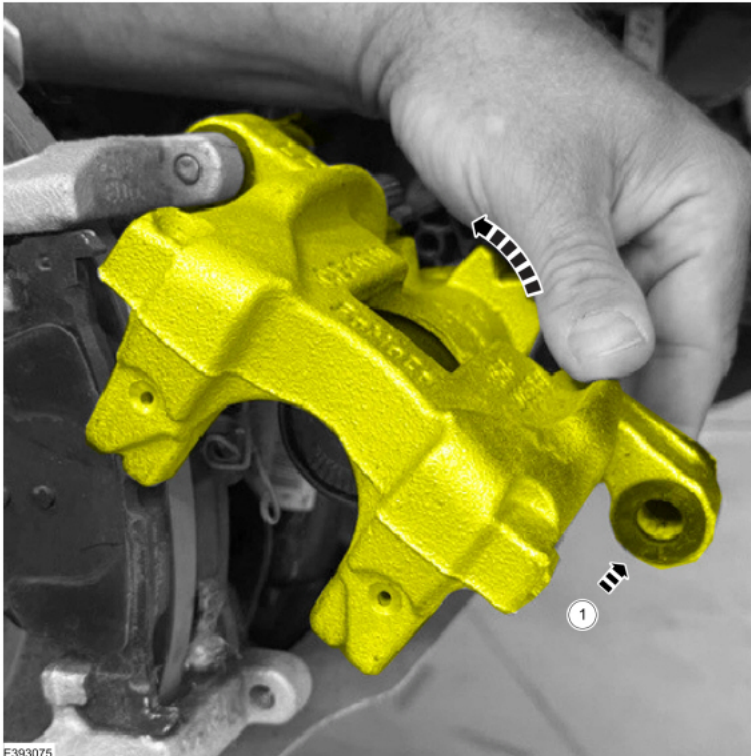

Figure 5



E393074

6. Rotate the rear caliper upwards to access to the bushing housing. (Figure 6, Callout 1)  
Figure 6



E393075

7. Using 6 in. slip joint pliers, remove and discard the standard bushing located on the opposite side of the bleeder. (Figure 7)  
Figure 7

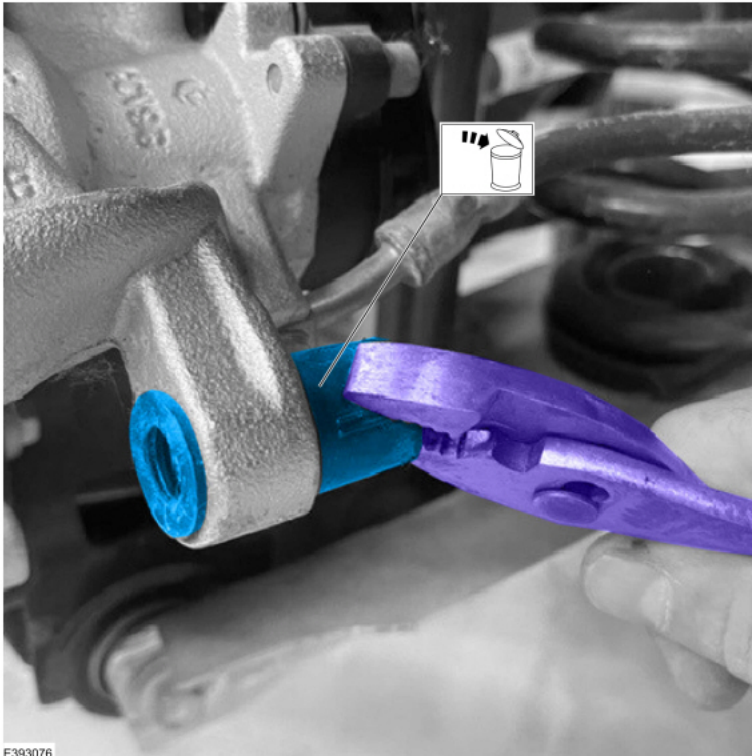

E393076

8. Install a new reinforced caliper bushing.

Figure 8 - Rear reinforced bushing kit contents



E393077

Item	Description
1	Standard bushing (1 piece)
2	Reinforced bushing (1 piece)
3	Guide pins (2 pieces)
4	Guide pin caps (2 pieces)

(1). Use a 1/2 in. drum sander bit to clean the caliper bushing housing. (Figure 9)

Figure 9

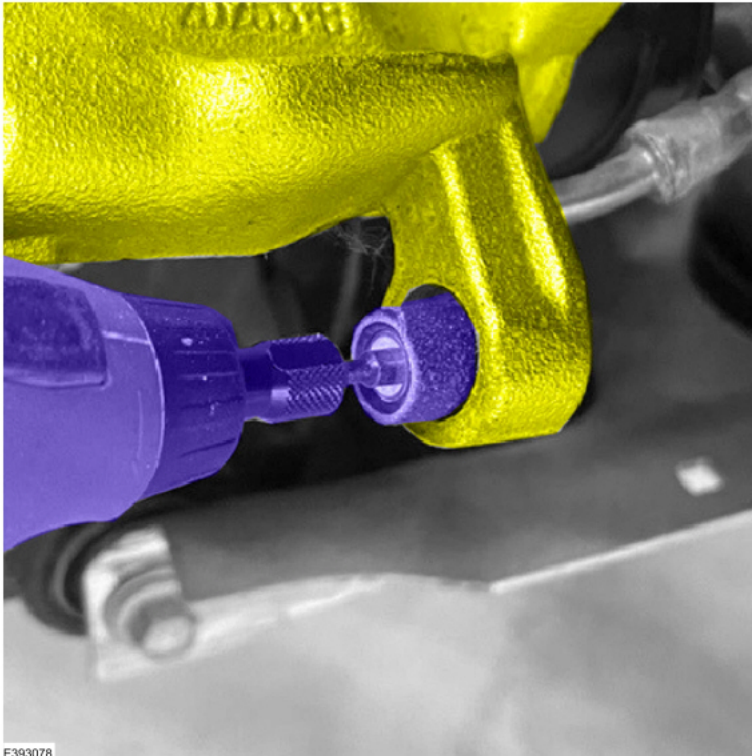

E393078

(2). Use Motorcraft® Metal Brake Parts Cleaner to remove any brake dust from the bushing housing.

(3). Lubricate the bushing and bushing housing with Motorcraft® Silicone Brake Caliper Grease and Dielectric Compound. (Figures 10-11)

Figure 10



E393079

Figure 11



E393080

- (4). Use an appropriate diameter socket, such as a 13 mm 3/8 drive chrome deep socket, to push the bushing into the caliper bushing housing. (Figures 12-14)
- Use a plastic trim tool to help guide the bushing into the housing.

Figure 12

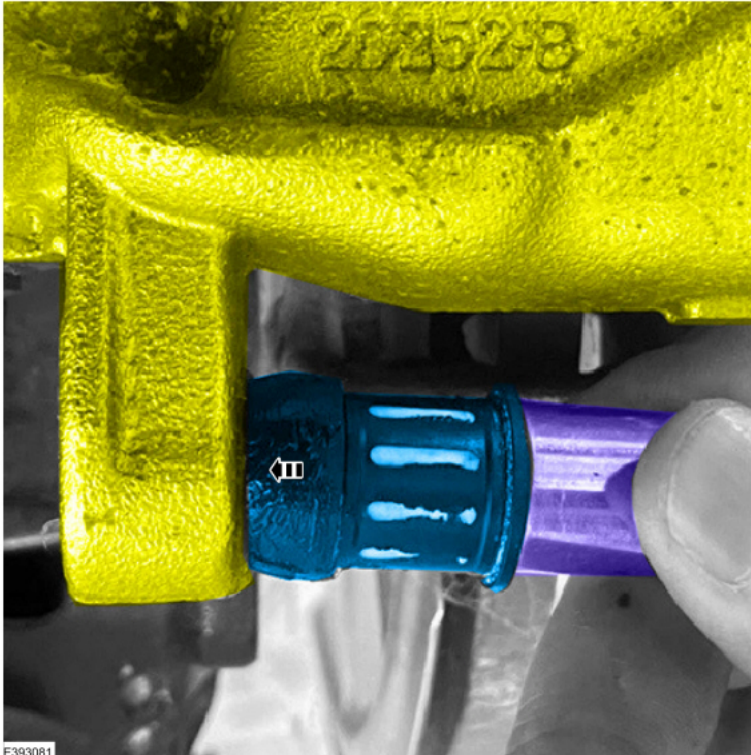

E393081

Figure 13

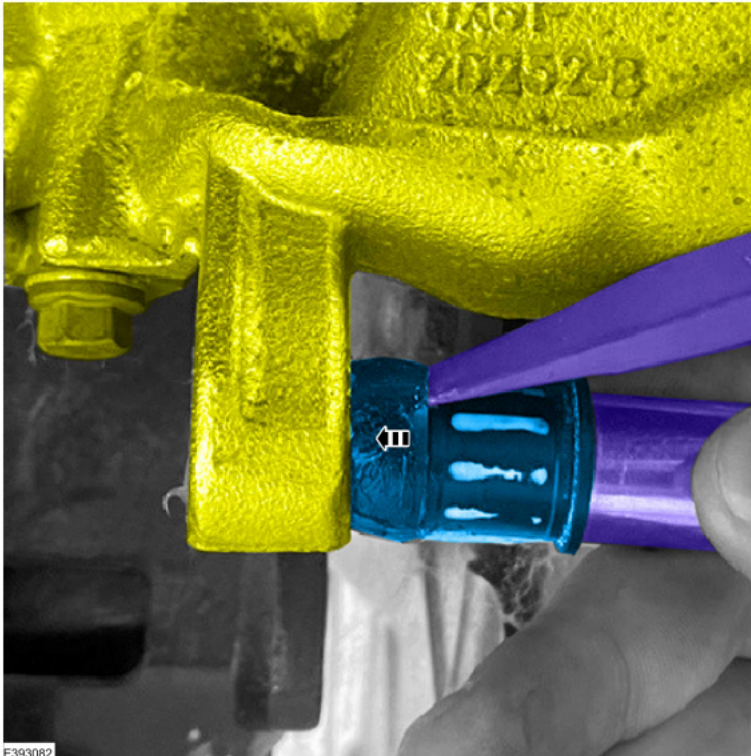

E393082

Figure 14



E393083

9. Rotate the rear caliper downwards. (Figure 15)

Figure 15



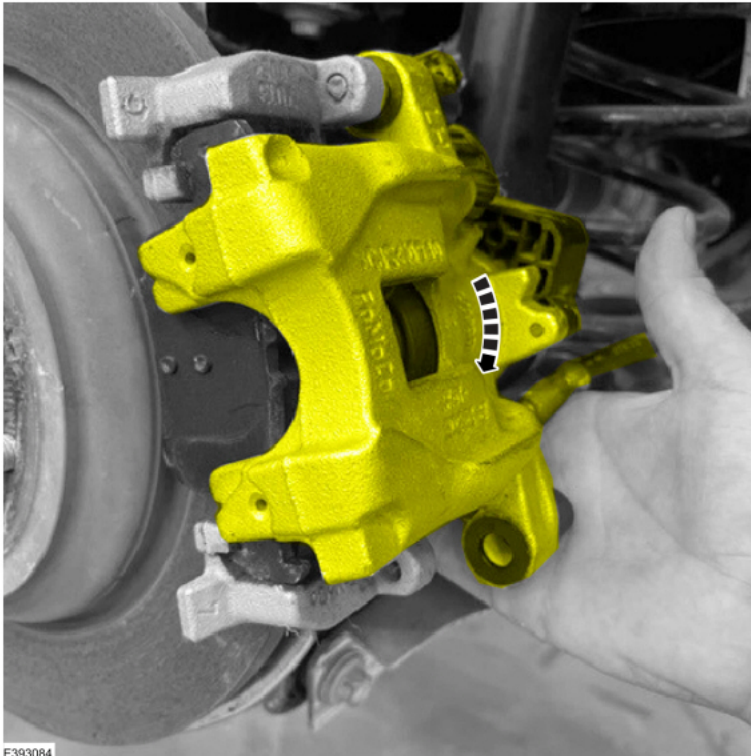

**10. Install a new guide pin.**

- (1). Tighten the guide pin to 28 Nm (21 lb-ft) and install a new guide pin cap.

**11. To assemble the vehicle, reverse the removal procedure.**

**12. Deactivate the brake service mode. Refer to the WSM, Section 206-00 Brake System > General Information > General Procedures.**

---

© 2022 Ford Motor Company  
All rights reserved.

NOTE: The information in Technical Service Bulletins is intended for use by trained, professional technicians with the knowledge, tools, and equipment to do the job properly and safely. It informs these technicians of conditions that may occur on some vehicles, or provides information that could assist in proper vehicle service. The procedures should not be performed by "do-it-yourselfers". Do not assume that a condition described affects your car or truck. Contact a Ford or Lincoln dealership to determine whether the Bulletin applies to your vehicle. Warranty Policy and Extended Service Plan documentation determine Warranty and/or Extended Service Plan coverage unless stated otherwise in the TSB article. The information in this Technical Service Bulletin (TSB) was current at the time of printing. Ford Motor Company reserves the right to supersede this information with updates. The most recent information is available through Ford Motor Company's on-line technical resources.