



TECHNICAL SERVICE BULLETIN

2021-2022 Bronco - Soft Top Roof – Excessive Wind Noise, Loose Cover, And/Or Difficulty Latching

22-2296

21 July 2022

Model:

Ford 2021-2022 Bronco

Issue: Some 2021-2022 Bronco vehicles equipped with a factory soft top roof may experience excessive wind noise while driving, loose soft top cover, and/or difficulty latching. This may be due incorrect soft top assembly installation, latch striker positioning and/or a failed soft top component. To correct the conditions, follow the Service Procedure to inspect the vehicle and adjust the soft top components as necessary.

Action: Follow the Service Procedure to correct the condition on vehicles that meet all of the following criteria:

- 2021-2022 Bronco
- Equipped with a factory soft top roof
- At least one of the following symptoms:
 - Excessive wind noise originating from the soft top roof
 - Loose soft top cover
 - Difficulty latching the center and/or front roof latches

Warranty Status: Eligible under provisions of New Vehicle Limited Warranty (NVLW)/Service Part Warranty (SPW)/Special Service Part (SSP)/Extended Service Plan (ESP) coverage. Limits/policies/prior approvals are not altered by a TSB. NVLW/SPW/SSP/ESP coverage limits are determined by the identified causal part and verified using the OASIS part coverage tool.

Labor Times

Description	Operation No.	Time
2021-2022 Bronco Inspect and Repair Soft Top Roof Following The Service Procedure	MT222296	Actual Time

Repair/Claim Coding

Causal Part:	7853000
Condition Code:	12

Service Procedure

1. Inspect both rear quarter windows and rear window attachments. For window operation, refer to the Digital Owner’s Manual located in the vehicle’s center touch screen by selecting Features > Owner’s Manual > Removable Vehicle Components > Removable Soft Top > Opening and Closing the Soft Top.
 - (1). Inspect the rear quarter windows for damage and properly securement at the C and D-pillars.
 - (2). Inspect all window upper buckles to be sure they are free of damage and properly secured. Adjust or repair as necessary.
 - (3). Inspect the hook and loop fasteners that run along the top of the windows making sure they are free of damage and properly secured at all locations. Adjust or repair as necessary.
 - (4). Inspect the tension cable routing as it relates to the rear quarter window. The rear quarter window should be tucked behind the cable. (Figure 1)

Figure 1 - Left side shown, right side similar

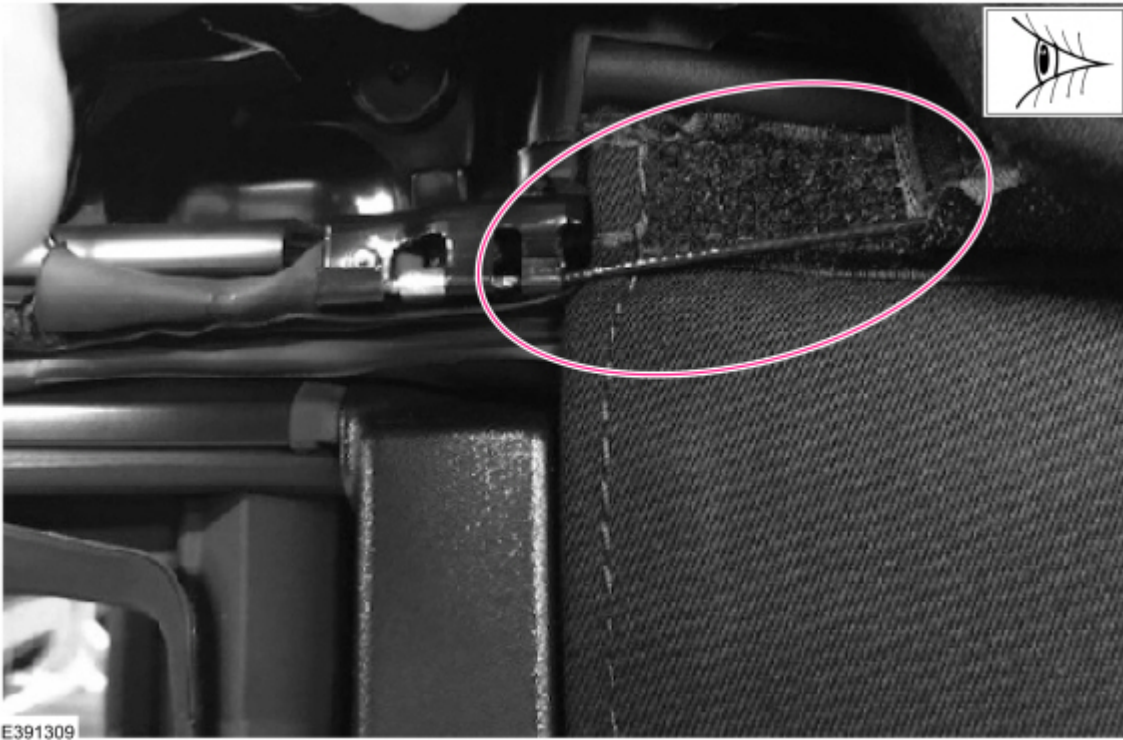

2. Is the concern still present?

- (1). Yes - proceed to Step 2.
- (2). No – repair is complete.

3. Locate the front tension cable brackets. These can be found on each side of the vehicle just above and behind the A-pillars. Lift this area of the soft top cover to gain access. (Figure 2)

Figure 2 - Left side shown, right side similar

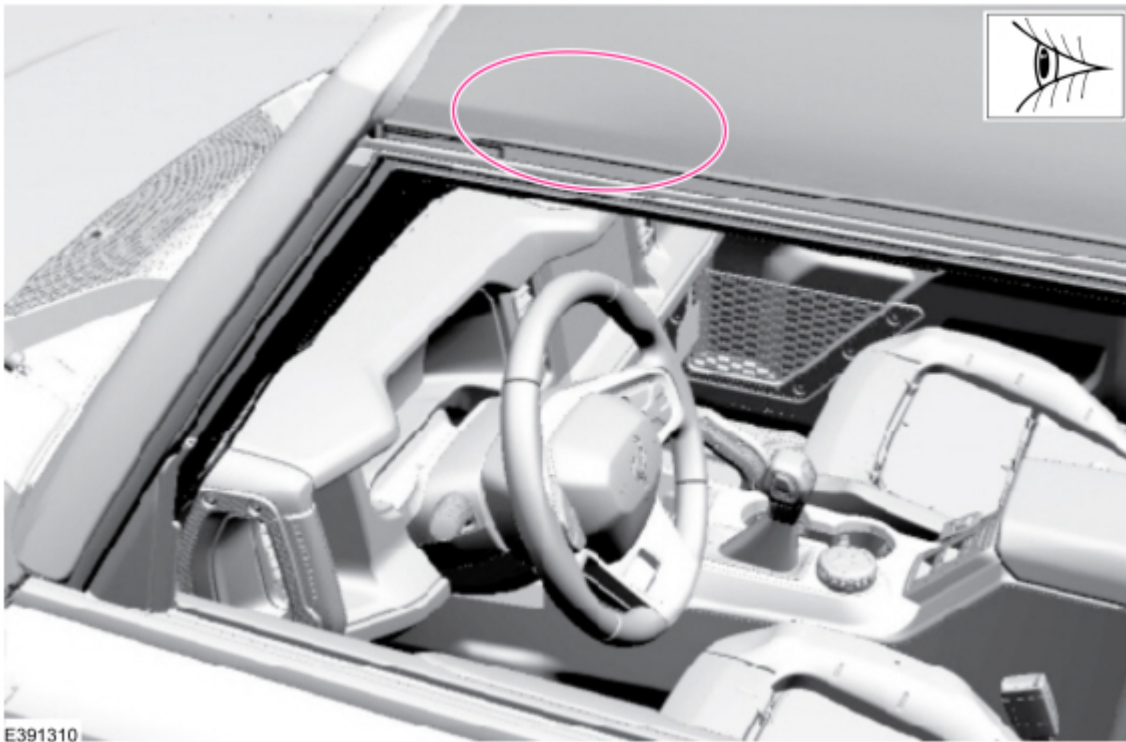

4. Inspect the front tension cable and the bracket.

- (1). Disengage and lift the plastic flap covering the bracket out of the way. (Figure 3)

Figure 3 - Left side shown, right side similar



(2). Be sure the cable lobe is secured in the most vehicle-forward position. (Figure 3). Adjust or repair as necessary.

(3). If the vehicle does not have tape installed over the front bracket and cable lobe, install a 1.9 in. x 1.4 in. (30 mm x 35 mm) strip of UHMW tape over the bracket and cable assembly. Wrap the tape around the back and front of the bracket. The tape should cover the bracket and tension cable lobe. (Figure 4)

Figure 4 - Left side shown, right side similar



(4). Repeat Step 4 on the opposite side of the vehicle then proceed to Step 5.

5. Is the concern still present?

(1). Yes - proceed to Step 6.

(2). No - repair is complete.

6. Inspect the rear tension cable and bracket.

(1). Locate the rear tension cable brackets. These can be found on each side of the vehicle, just above C-pillars. Lift this area of the soft top cover to gain access. (Figure 5)

Figure 5 - Left side shown, right side similar

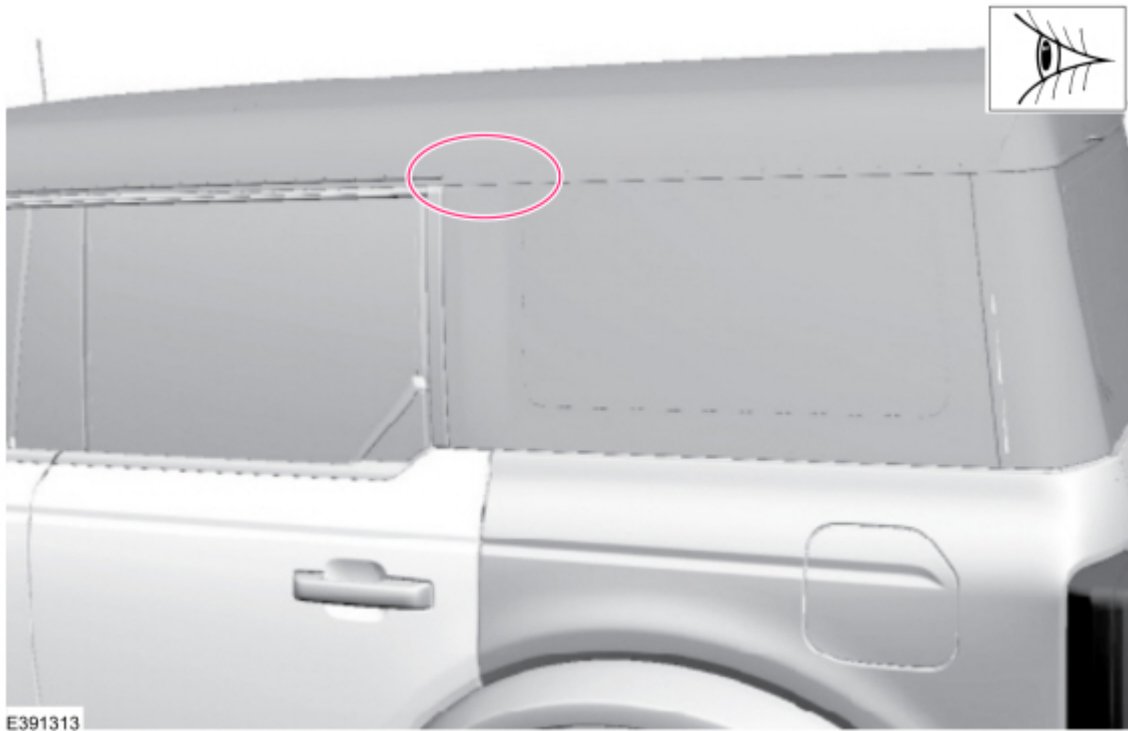

(2). Inspect the rear tension cable lobe position inside the bracket. The tension cable lobe should be secured in the most vehicle-forward position. The tension cable should not be loose or easily removable. Adjust or repair as necessary. (Figure 6)

Figure 6 - Left side shown, right side similar

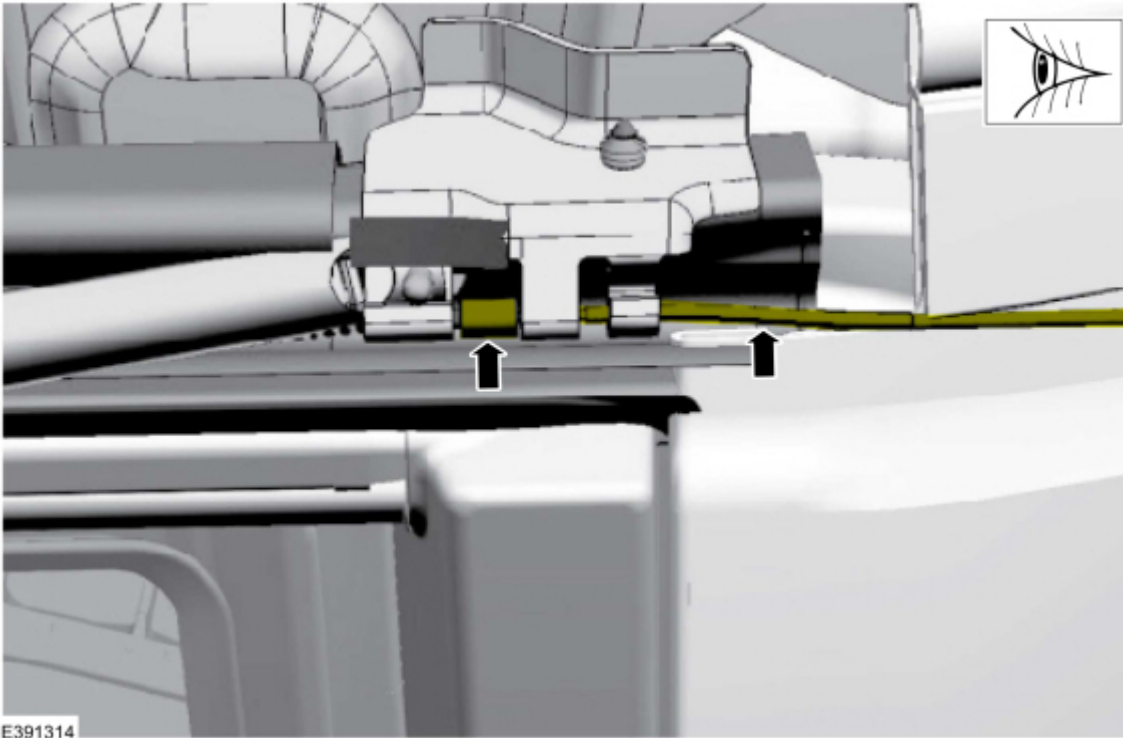

(3). Inspect the rear tension cable spring for proper attachment to the bracket. Adjust or repair as necessary. (Figure 7)

Figure 7 - Left side shown, right side similar

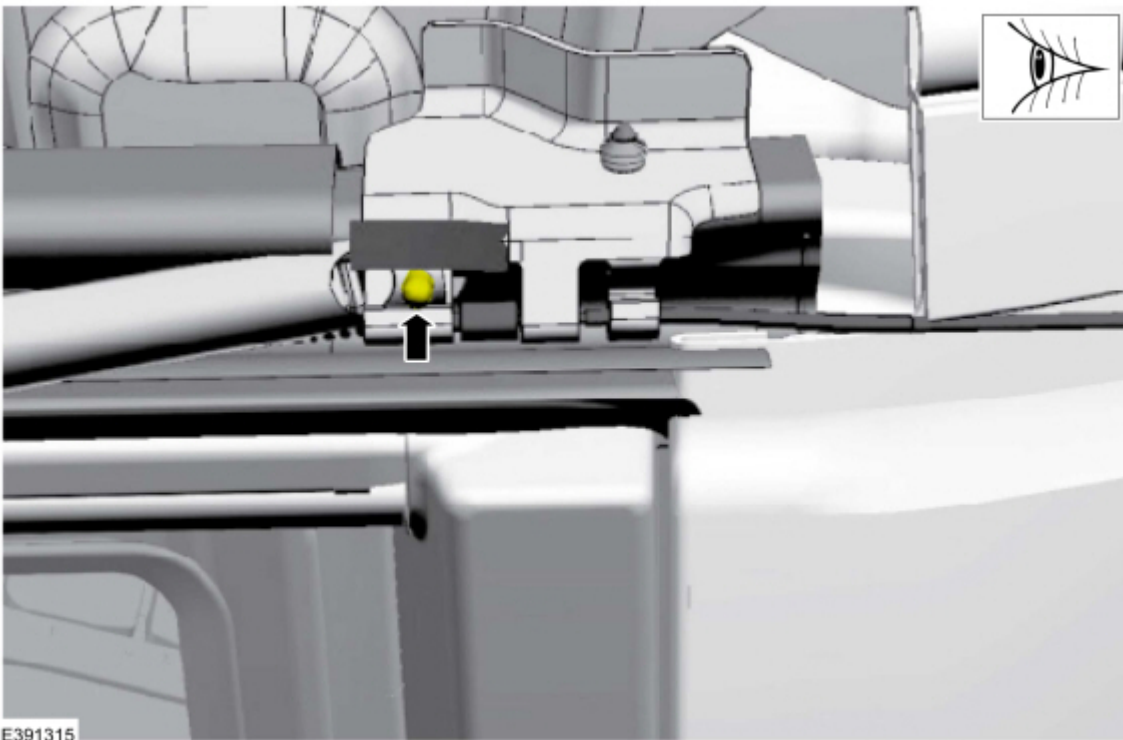

(4). Repeat Step 6 on the opposite side then proceed to Step 7.

7. Is the concern still present?

- (1). Yes – proceed to Step 8
- (2). No – repair is complete.

8. Reseat the soft top assembly to the vehicle body.

(1). Place the soft top halfway between the partially open and fully open position. This will place the soft top assembly center of gravity directly above the soft top assembly mounting positions. Refer to the Digital Owner's Manual located in the vehicle's center display screen by selecting Features > Owner's Manual > Removable Vehicle Components > Removable Soft Top > Opening and Closing the Soft Top.

(2). Remove both access covers to gain access to the 6 bolts (3 on each side) that secure the soft top frame to the body. (Figure 8)

Figure 8 - Left side shown, right side similar

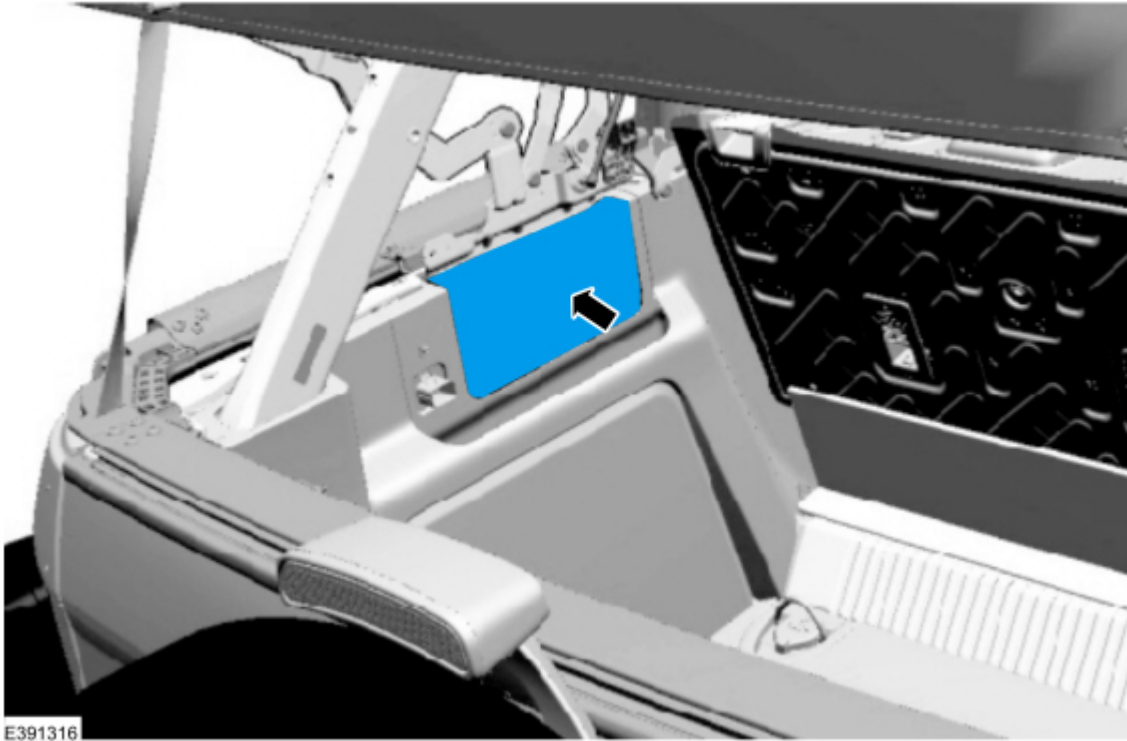

(3). Loosen all 6 soft top assembly mounting bolts (3 on each side) just enough to allow the soft top assembly to shift. (Figure 9, Callout 2)

Figure 9 - Left side shown, right side similar



(4). Starting on the left side, pull the soft top frame down so that it is contacting both dowels on the body (Figure 9, Callout 1) then tighten all 3 soft top assembly bolts to 106 lb.in (12 Nm) (Figure 9, Callout 2). Repeat this step on the right side. Before proceeding, make sure both sides of the soft top frame are contacting the dowels. Repeat this Step as needed to make further adjustments.

(5). Test the soft top movement by placing it in the fully open, partially open, and fully closed positions. Refer to the Digital Owner's Manual located in the vehicle's center display screen by selecting Features > Owner's Manual > Removable Vehicle Components > Removable Soft Top > Opening and Closing the Soft Top.

9. Does the soft top properly latch on both middle and both front latches?

(1). Yes - repair is complete. If concern persists, refer to the WSM, Section 501-18A.

(2). No - proceed to Step 10.

10. Adjust the middle and front latch strikers.

(1). Place the soft top in the fully open position. Refer to the Digital Owner's Manual located in the vehicle's center display screen by selecting Features > Owner's Manual > Removable Vehicle Components > Removable Soft Top > Opening and Closing the Soft Top.

(2). Loosen the two bolts on each middle latch striker allowing them to shift in place. (Figure 10)

Figure 10 - Left side shown, right side similar

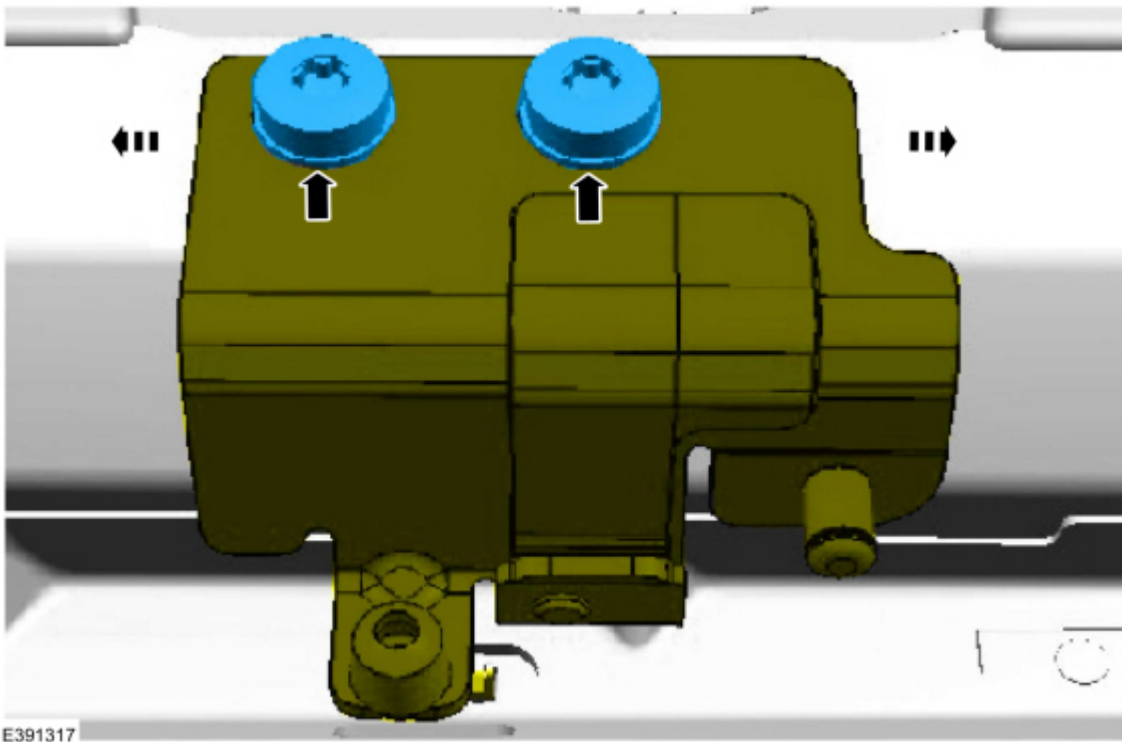

(3). Remove the plastic covers from both front latch strikers. (Figure 11)

Figure 11 - Left side shown, right side similar

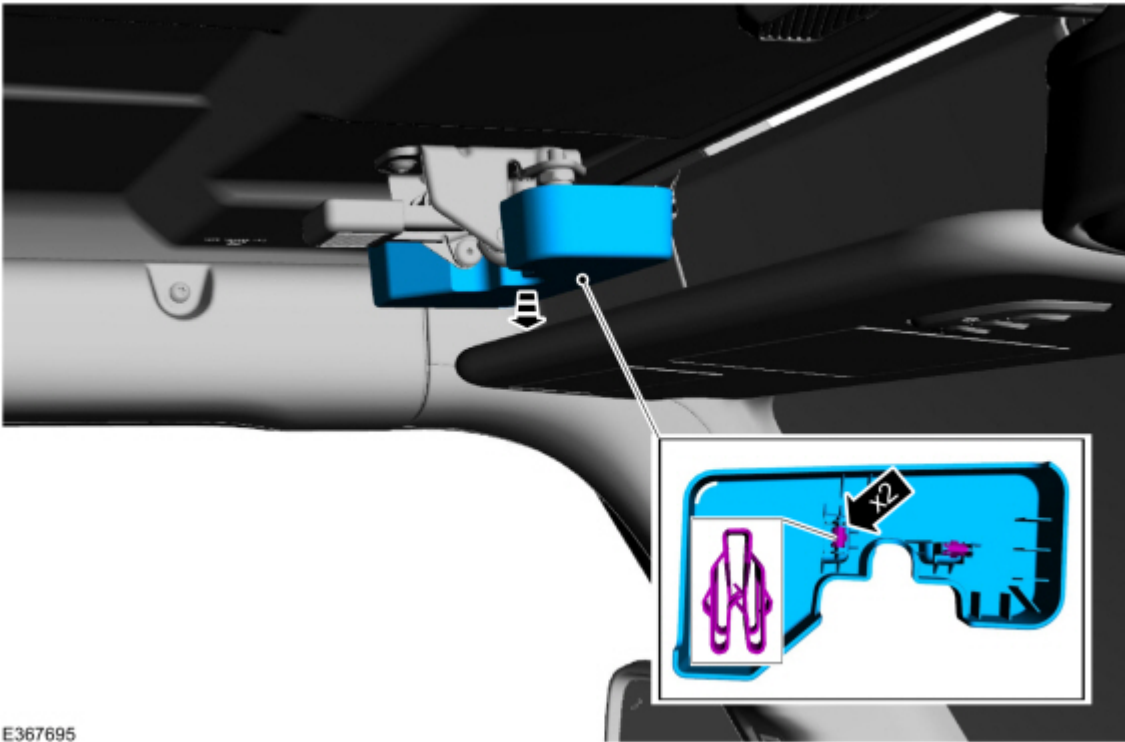

E367695

(4). Loosen the two bolts on each front latch striker allowing them to shift in place. (Figure 12)
 Figure 12 - Left side shown, right side similar

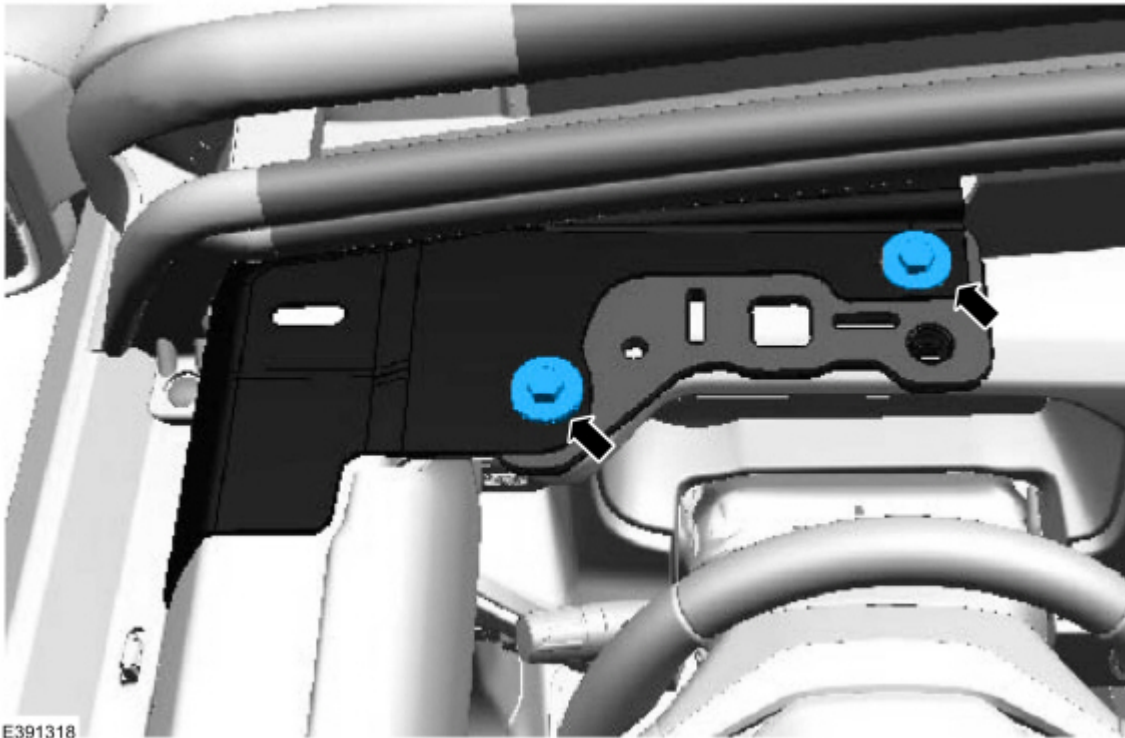

E391318

- (5). Place the soft top in the fully closed position. Be sure to latch all middle and front latches to the loose strikers. Refer to the Digital Owner's Manual located in the vehicle's center display screen by selecting Features > Owner's Manual > Removable Vehicle Components > Removable Soft Top > Opening and Closing the Soft Top.
- (6). Hand tighten the front latch striker bolts temporarily holding the strikers in place. These can be accessed using fingers from inside the vehicle.
- (7). Carefully place the soft top in the partially open position. Refer to the Digital Owner's Manual located in the vehicle's center display screen by selecting Features > Owner's Manual > Removable Vehicle Components > Removable Soft Top > Opening and Closing the Soft Top.

(8). Tighten the front latch striker bolts to 15 lb-ft (20 Nm).

(9). Adjust the middle latch strikers.

- Starting on the left side, find the correct position for the striker by operating the middle latch and slowly lifting and lowering the soft top until smooth operation is achieved with both latching and unlatching.
- Be sure the latch sits tight enough to the striker that it cannot be disengaged without operating the latch.
- Once the proper location of the middle striker has been achieved, tighten the middle latch striker bolts to 15 lb-ft (20 Nm).
- Repeat Step 10(9) on the right side. (Figure 10)

(10). Retest soft top movement by placing it in the fully open, partially open, and fully closed positions. Refer to the Digital Owner's Manual located in the vehicle's center display screen by selecting Features > Owner's Manual > Removable Vehicle Components > Removable Soft Top > Opening and Closing the Soft Top. If additional adjustments are needed, repeat Steps 8-10 as needed until proper alignment is achieved.

11. If the original concern has not been resolved, refer to WSM, Section 501-18A.

© 2022 Ford Motor Company

All rights reserved.

NOTE: The information in Technical Service Bulletins is intended for use by trained, professional technicians with the knowledge, tools, and equipment to do the job properly and safely. It informs these technicians of conditions that may occur on some vehicles, or provides information that could assist in proper vehicle service. The procedures should not be performed by "do-it-yourselfers". Do not assume that a condition described affects your car or truck. Contact a Ford or Lincoln dealership to determine whether the Bulletin applies to your vehicle. Warranty Policy and Extended Service Plan documentation determine Warranty and/or Extended Service Plan coverage unless stated otherwise in the TSB article. The information in this Technical Service Bulletin (TSB) was current at the time of printing. Ford Motor Company reserves the right to supersede this information with updates. The most recent information is available through Ford Motor Company's on-line technical resources.