



TECHNICAL SERVICE BULLETIN

Single Rear Wheel Only - Boom/Hum/Moan Noise Or Vibration From Rear While Driving At Highway Speeds

22-2175

04 May 2022

This bulletin supersedes 22-2043.

Model:

Ford 2015-2022 Transit	Single Rear Wheel Only (Does Not Apply To Dual Rear Wheel Vehicles)
---------------------------	---

Summary

This article supersedes TSB 22-2043 to update the vehicle model years affected.

Issue: Some 2015-2021 Transit vehicles equipped with rear wheel drive (RWD), single rear wheel only, and a U-joint at the transmission flange and rear driveshaft may experience a boom/hum/moan noise or vibration from the rear while driving. This noise or vibration is most noticeable at highway speeds:

- 112-121 km/h (70-75 mph) for 4.10 axle ratio
- 121-128 km/h (75-80 mph) for 3.73 axle ratio
- 136-145 km/h (85-90 mph) for 3.31 axle ratio

The noise or vibration may also be present to a lesser degree at roughly half of those speeds. This may be due to a 2nd order driveline frequency transmitted through the rear driveshaft, rear axle and into the body through the leaf springs. To correct the condition, follow the Service Procedure to install a driveshaft torsional damper.

Action: Follow the Service Procedure steps to correct the condition on vehicles that meet all of the following criteria:

- 2015-2021 Transit
- Single rear wheel only
- RWD
- Boom/hum/moan noise or vibration at highway speeds
- U-joint at the transmission flange and rear driveshaft

NOTE: This article does not apply to dual rear wheel (DRW) vehicles.

Parts

Service Part Number	Quantity	Description
LK4Z-4A263-C	1	Torsional Damper Kit

Special Tool(s)

Mastertech® Series MTS 4000 Driveline Balance and NVH Analyzer

Warranty Status: Eligible under provisions of New Vehicle Limited Warranty (NVLW)/Service Part Warranty (SPW)/Special Service Part (SSP)/Extended Service Plan (ESP) coverage. Limits/policies/prior approvals are not altered by a TSB. NVLW/SPW/SSP/ESP coverage limits are determined by the identified causal part and verified using the OASIS part coverage tool.

Labor Times

Description	Operation No.	Time
2015-2022 Transit: Diagnose, Inspect The Rear Driveshaft, Install A Driveshaft Torsional Damper And Torsion Damper Shield Includes Time To Remove The Pinion Nose Damper If	222175A	1.1 Hrs.

Equipped (Do Not Use With Any Other Labor Operations Outside Of This Article)		
2020-2022 Transit Additional Time To Remove And Install Running Boards When Necessary (Can Be Claimed With Operation A)	222175B	0.3 Hrs.

Repair/Claim Coding

Causal Part:	4A263
Condition Code:	D9

Service Procedure



CAUTION: This article does not apply to vehicles with dual rear wheels. If this service part kit is installed on dual rear wheel vehicles, the parking brake cable may contact the torsional damper shield due to insufficient clearance between the shield and the parking brake cable, leading to abrasion of the parking brake cable. Over time, abrasion of the parking brake cable could result in cable failure. If the parking brake cable fails, the park brake will no longer function to hold the vehicle in place creating the risk of unintended vehicle movement.

1. Using the Mastertech® Series MTS 4000 Driveline Balance and NVH Analyzer (Vetronix) or equivalent, analyze the noise or vibration to determine the order. Does analysis identify the concern as a 2nd order driveline vibration?
 - (1). Yes - proceed to Step 2.
 - (2). No - this article does not apply. Refer to Workshop Manual (WSM), Section 205-01.
2. Inspect the rear driveshaft, driveshaft joints, driveshaft center bearing(s) and slip yoke splines for damage or wear. Refer to WSM, Section 205-01. Is there evidence of damage or wear to the driveshaft, driveshaft U-joints or slip yoke splines?
 - (1). Yes - this article does not apply. Refer to WSM, Section 205-01.
 - (2). No - proceed to Step 3.
3. Mark the pinion flange and rear driveshaft U-joint to enable correct indexing of the driveshaft during installation. Refer to WSM, Section 205-01.
4. If equipped, remove and discard the pinion nose damper from the axle assembly.
5. Remove and discard the driveshaft to axle pinion flange bolts. With a suitable strap, support the driveshaft so there is no undue stress applied to the rear driveshaft-to-transmission output flange joint or rear driveshaft center bearing(s). Refer to WSM, Section 205-01 Removal and Installation, Rear Driveshaft.

NOTE: The maximum articulation of any U-joint is 10 degrees. If the driveshaft U-joint is articulated further than the maximum allowable degrees damage may occur.

6. Inspect the pinion flange to driveshaft mating surface for any debris or excessive rust and clean as necessary.
7. Install the driveshaft torsional damper on the axle pinion flange. (Figure 1)

Figure 1

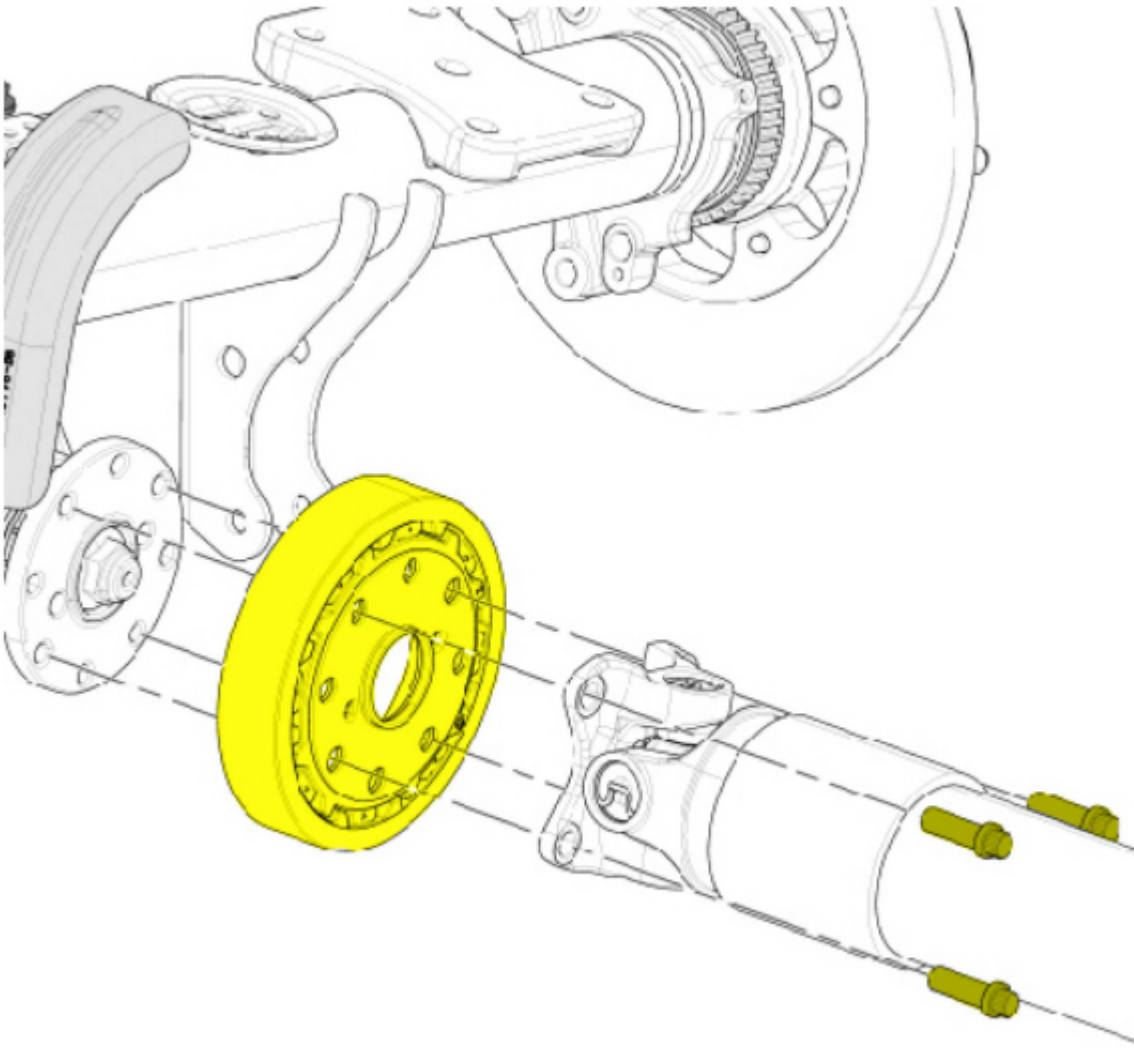

E337352

8. Align the index mark on the driveshaft and rear drive pinion flange and reinstall the driveshaft. Make sure the driveshaft fits securely over the raised flange on the torsional damper.

(1). Install the driveshaft attaching bolts and tighten to 115 Nm (85 lb-ft) Refer to WSM, Section 205-01. (Figure 1)

9. Using the existing holes in the axle housing, install the torsion damper shield to the right side of the axle assembly near the pinion. Install the 2 bolts and the nut supplied in the torsional damper kit. Tighten to 48 Nm (35 lb-ft). (Figure 2)

Figure 2

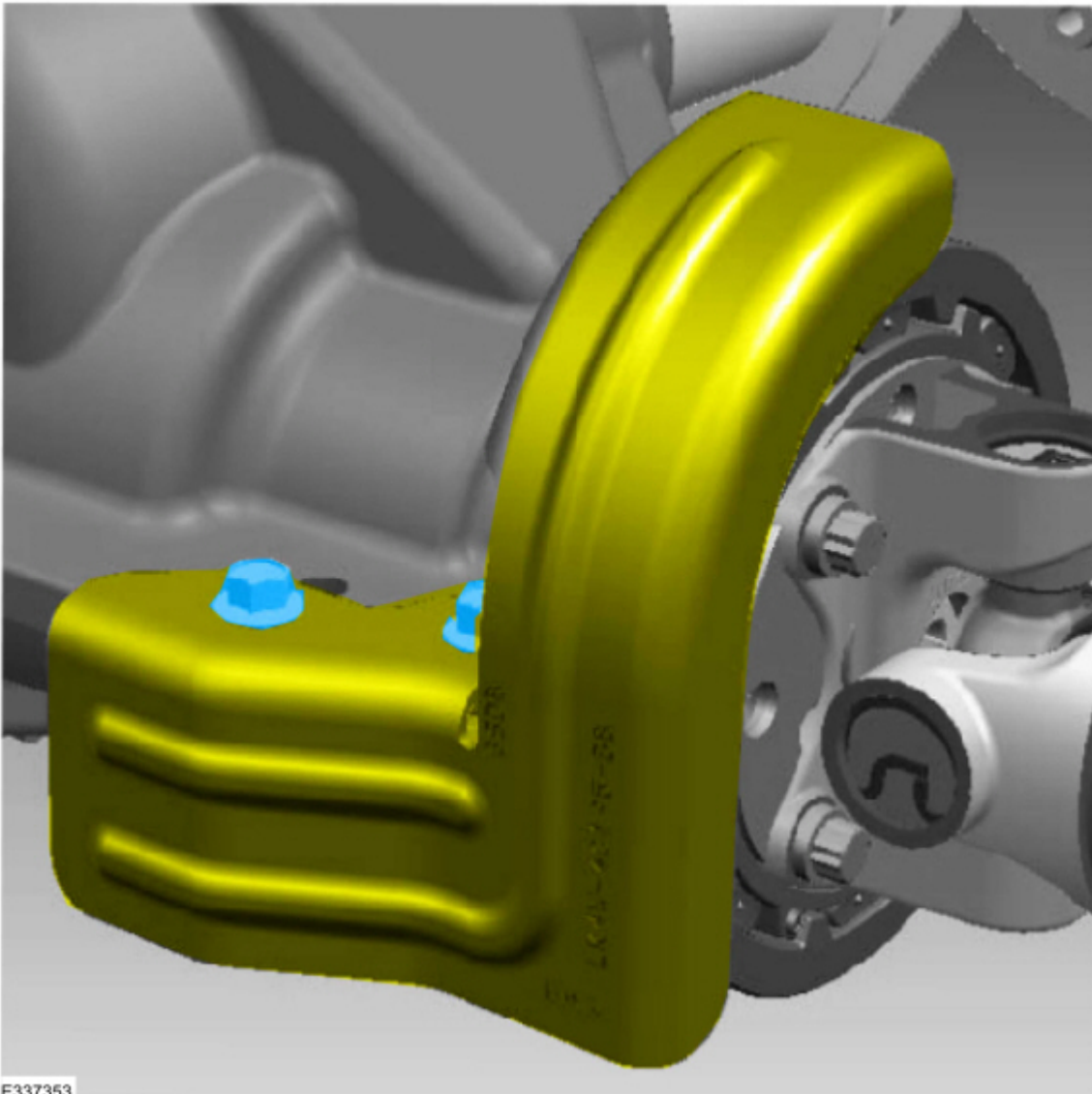

E337353

© 2022 Ford Motor Company

All rights reserved.

NOTE: The information in Technical Service Bulletins is intended for use by trained, professional technicians with the knowledge, tools, and equipment to do the job properly and safely. It informs these technicians of conditions that may occur on some vehicles, or provides information that could assist in proper vehicle service. The procedures should not be performed by "do-it-yourselfers". Do not assume that a condition described affects your car or truck. Contact a Ford or Lincoln dealership to determine whether the Bulletin applies to your vehicle. Warranty Policy and Extended Service Plan documentation determine Warranty and/or Extended Service Plan coverage unless stated otherwise in the TSB article. The information in this Technical Service Bulletin (TSB) was current at the time of printing. Ford Motor Company reserves the right to supersede this information with updates. The most recent information is available through Ford Motor Company's on-line technical resources.