



TECHNICAL SERVICE BULLETIN

Wind/Whistle Noise From Front A-Pillar Applique

22-2021
31 January 2022

Model:

Ford 2020-2022 Explorer
Lincoln 2020-2022 Aviator

Issue: Some 2020-2022 Explorer/Aviator vehicles may exhibit a wind/whistle type noise at highway speeds originating from the front A-pillar applique (either side or both). This may be due to a small gap between the outboard side of the A-pillar applique and the moulding. To correct the condition, follow the Service Procedure to install thin strips of flock tape on the A-pillar applique.

Action: Follow the Service Procedure to correct the condition on vehicles that meet the following criteria:

- 2020-2022 Explorer/Aviator
- Wind/whistle noise from the front of the vehicle (A-pillar applique) at highway speeds

Parts

Service Part Number	Quantity	Description
164-R4903	As Needed	Flock Tape (Rotunda Part Number)

As Needed indicates the amount of the part may vary and/or is not a whole number. Parts can be billed out as non-whole numbers, including less than 1.

Parts

Parts To Use Only If The Flock Tape Is Not Available Separately

Service Part Number	Quantity	Description
164-R4900	If Needed	Rotunda Squeak and Rattle Kit (Rotunda Part Number)

If Needed indicates the part is not mandatory.

Warranty Status: Eligible under provisions of New Vehicle Limited Warranty (NVLW)/Service Part Warranty (SPW)/Special Service Part (SSP)/Extended Service Plan (ESP) coverage. Limits/policies/prior approvals are not altered by a TSB. NVLW/SPW/SSP/ESP coverage limits are determined by the identified causal part and verified using the OASIS part coverage tool.

Labor Times

Description	Operation No.	Time
2020-2022 Explorer/Aviator: Install Flock Tape On One (1) Side Of The Vehicle Following The Service Procedure (Do Not Use With Any Other Labor Operations)	222021A	0.3 Hrs.
2020-2022 Explorer/Aviator: Install Flock Tape On Both (2) Sides Of The Vehicle Following The Service Procedure (Do Not Use With Any Other Labor Operations)	222021B	0.5 Hrs.

Repair/Claim Coding

Causal Part:	7802501
Condition Code:	33

Service Procedure

1. Using a non-marring trim removal tool, remove the A-pillar applique. Refer to Workshop Manual (WSM), Section 501-08. (Figure 1)

Figure 1

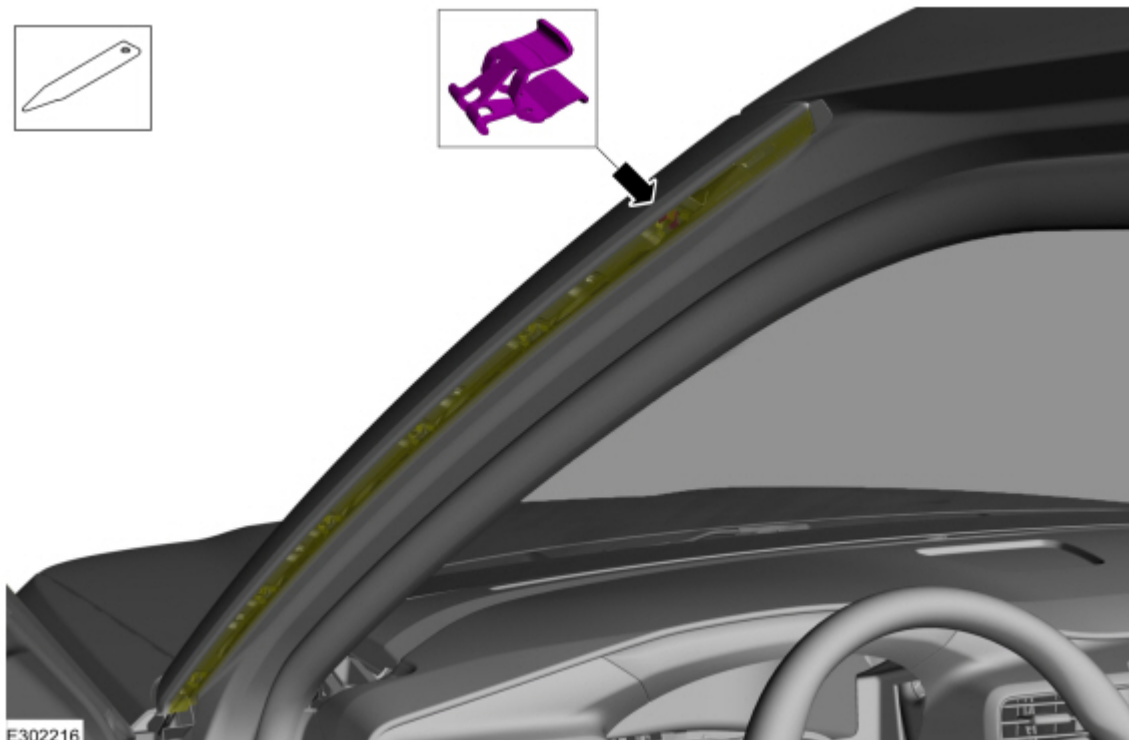

2. Using Flock Tape or equivalent from the Rotunda Squeak and Rattle Kit, cut a strip 10 mm (3/8 in.) wide by 100 mm (4 in.) long and apply it to the outboard edge of the moulding between callouts 2 and 4 of Figure 2.

Figure 2

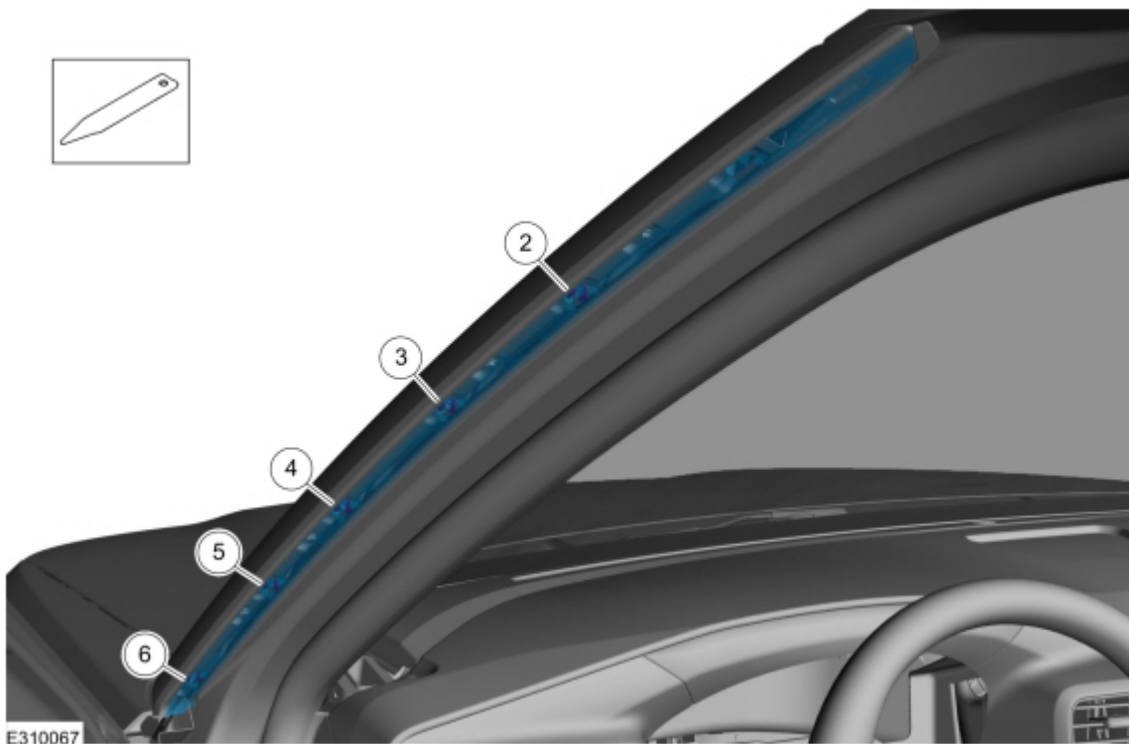

3. Reinstall the A-pillar applique. Refer to WSM, Section 501-08.

All rights reserved.

NOTE: The information in Technical Service Bulletins is intended for use by trained, professional technicians with the knowledge, tools, and equipment to do the job properly and safely. It informs these technicians of conditions that may occur on some vehicles, or provides information that could assist in proper vehicle service. The procedures should not be performed by "do-it-yourselfers". Do not assume that a condition described affects your car or truck. Contact a Ford or Lincoln dealership to determine whether the Bulletin applies to your vehicle. Warranty Policy and Extended Service Plan documentation determine Warranty and/or Extended Service Plan coverage unless stated otherwise in the TSB article. The information in this Technical Service Bulletin (TSB) was current at the time of printing. Ford Motor Company reserves the right to supersede this information with updates. The most recent information is available through Ford Motor Company's on-line technical resources.