



TECHNICAL SERVICE BULLETIN

1.0L EcoBoost - Cruise Control Inoperative, Illuminated Powertrain Malfunction (Wrench) Indicator And Brake Warning Indicator With DTC P0504

22-2011

21 January
2022

Model:

Ford 2021 EcoSport	Engine: 1.0L EcoBoost
------------------------------	-----------------------

Issue: Some 2021 EcoSport vehicles may exhibit a condition where the cruise control system is inoperative with an illuminated powertrain malfunction (wrench) indicator and illuminated brake warning indicator with diagnostic trouble code (DTC) P0504 stored in the powertrain control module (PCM). This may be due to the software in the PCM and/or an incorrectly installed stoplamp switch. To correct this condition, follow the Service Procedure to reprogram the PCM and check for the correct installation of the stoplamp switch.

Action: Follow the Service Procedure steps to correct the condition on vehicles that meet all of the following criteria:

- 2021 EcoSport
- 1.0L EcoBoost
- Illuminated powertrain malfunction (wrench) indicator
- Illuminated brake warning indicator with DTC P0504 stored in the PCM
- Cruise control inoperative

Warranty Status: Eligible under provisions of New Vehicle Limited Warranty (NVLW)/Service Part Warranty (SPW)/Special Service Part (SSP)/Extended Service Plan (ESP) coverage. Limits/policies/prior approvals are not altered by a TSB. NVLW/SPW/SSP/ESP coverage limits are determined by the identified causal part and verified using the OASIS part coverage tool.

Labor Times

Description	Operation No.	Time
2021 EcoSport 1.0L: Check For PCM Software Update (Not Available) Retrieve DTCs And Adjust The Stoplamp Switch Following The Service Procedure (Do Not Use With Any Other Labor Operations)	222011A	0.3 Hrs.
2021 EcoSport 1.0L: Check For And Update The PCM Software Retrieve DTCs Repair Complete (Do Not Use With Any Other Labor Operations)	222011B	0.4 Hrs.
2021 EcoSport 1.0L: Check For And Update The PCM Software Retrieve DTCs And Adjust The Stoplamp Switch Following The Service Procedure (Do Not Use With Any Other Labor Operations)	222011C	0.5 Hrs.

Repair/Claim Coding

Causal Part:	12A650
Condition Code:	04

Service Procedure

1. Using the latest version of the Ford Diagnosis and Repair System (FDRS), check the PCM for software updates. Does FDRS show there is a software update available for the PCM?

- (1). Yes - download and run the PCM – Powertrain Control Module (PCM) Software update app. Proceed to Step 2.

- (2). No - proceed to Step 2.
2. Is DTC P0504 present in the PCM after performing the PCM software update and/or has the stoplamp switch been recently replaced?
- (1). Yes - proceed to Step 3.
- (2). No - repair is complete.
3. Disconnect the electrical connector and remove the stoplamp switch (Figure 1-2). Refer to the Workshop Manual (WSM), Section 417-01 > Exterior Lighting > Removal and Installation. Is it difficult to rotate the stoplamp switch?

Figure 1

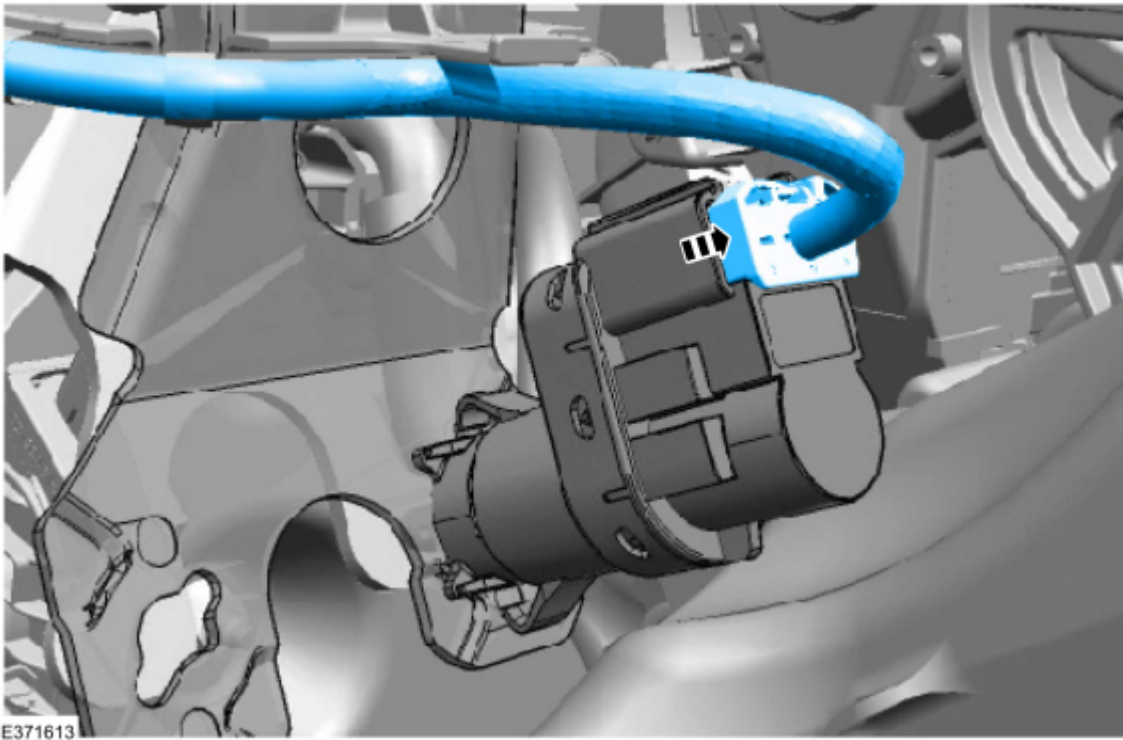
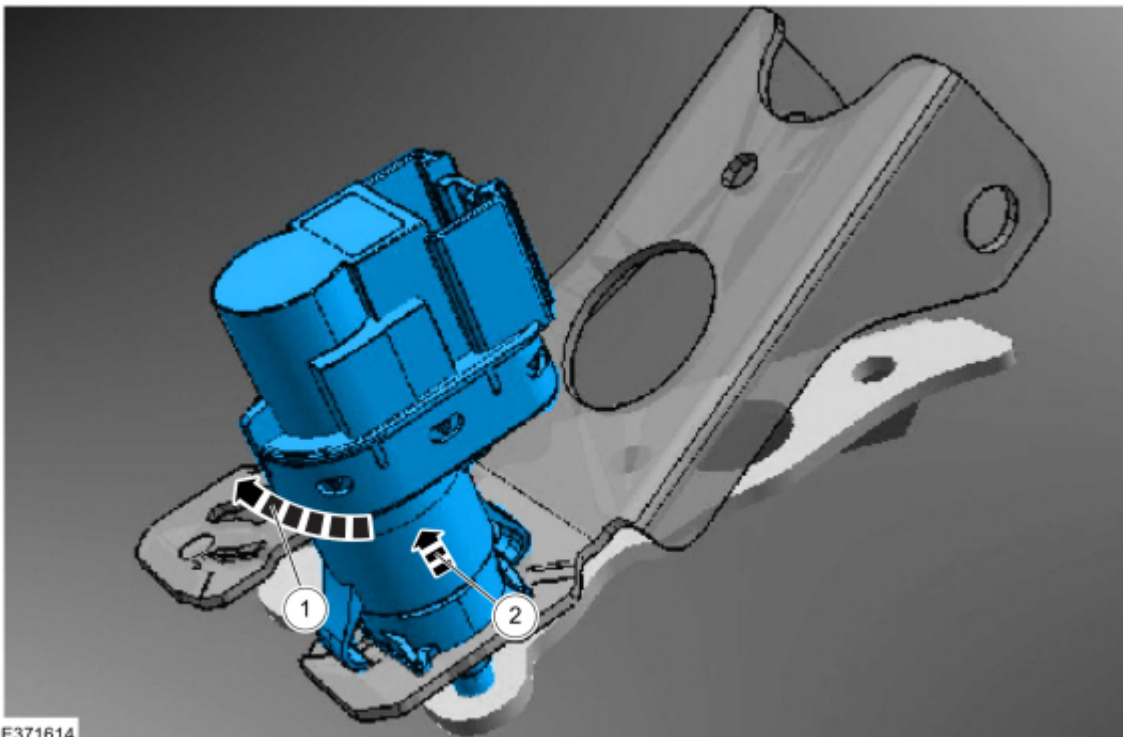

Figure 2



- (1). Yes - proceed to Step 4.
- (2). No - proceed to Step 5.

NOTE: Apply the force to remove and install the stoplamp switch. Applying excessive force during installation results in damage to the stoplamp switch.

4. Press and hold down the brake pedal. Rotate the switch 1/4 turn clockwise and at the same time slowly move the switch plunger into the switch body until the switch starts rotating. Remove the stoplamp switch (Figure 3-4).

Figure 3

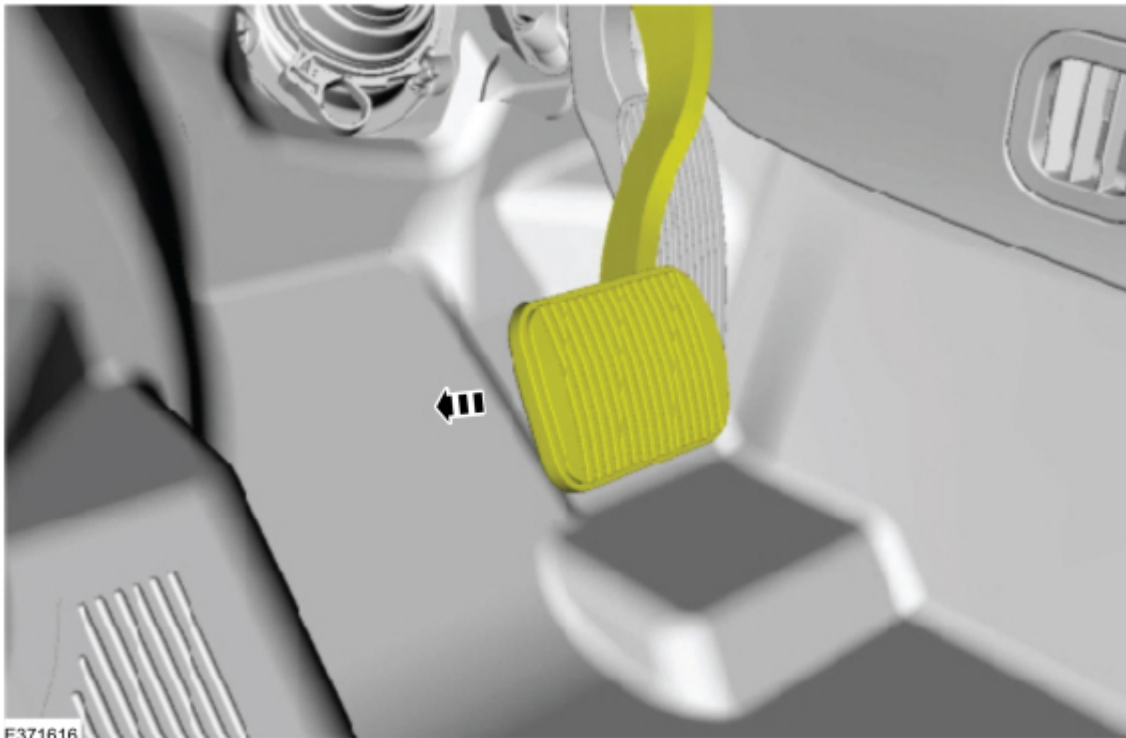
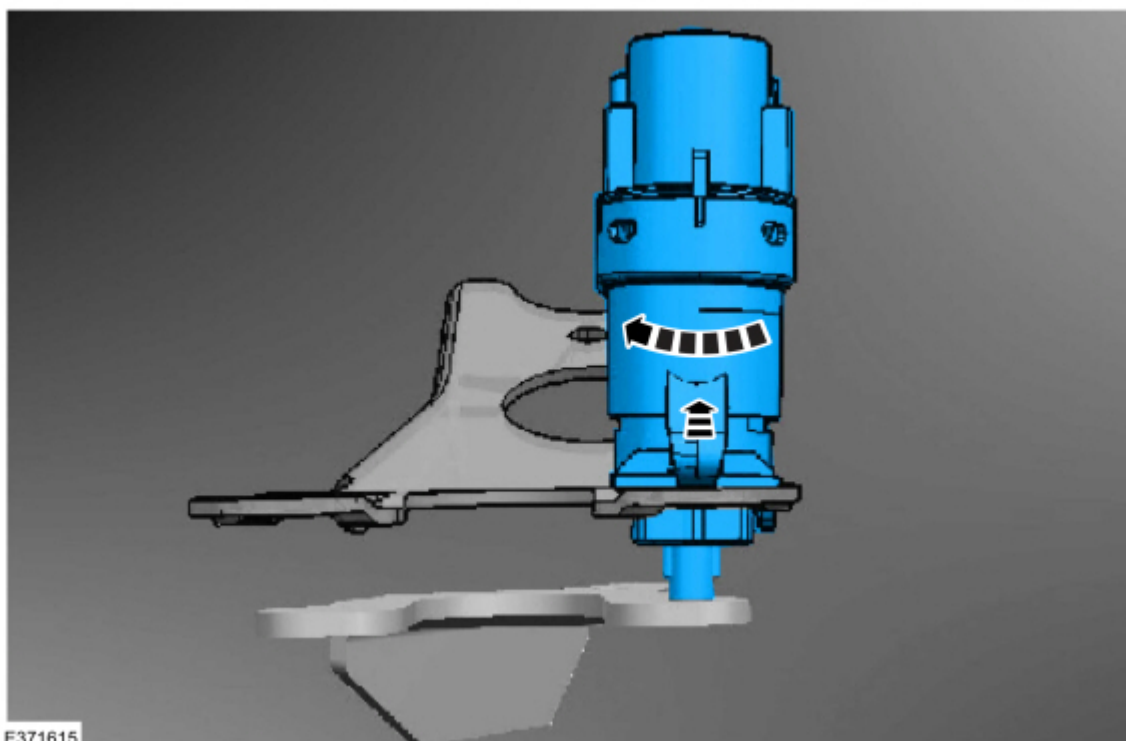
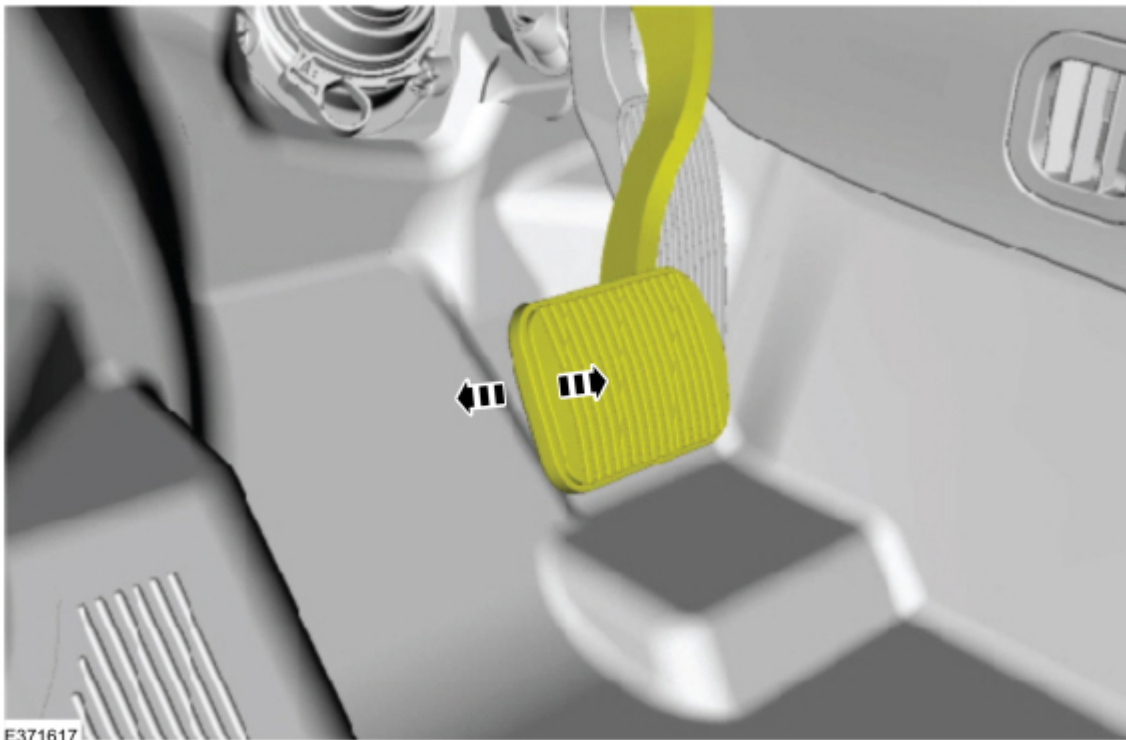

Figure 4



5. Apply the brake pedal 10 times, allowing it to return to the rest position before pressing it again (Figure 5). This helps remove the vacuum from the brake booster.

Figure 5



6. Reinstall the brake switch.

NOTE: Do not press or lift the brake pedal during the installation process.

- (1). Locate the switch in open position.
- (2). Rotate the switch 1/4 turn counterclockwise to reinstall.
- (3). Connect the electrical connector.

© 2022 Ford Motor Company

All rights reserved.

NOTE: The information in Technical Service Bulletins is intended for use by trained, professional technicians with the knowledge, tools, and equipment to do the job properly and safely. It informs these technicians of conditions that may occur on some vehicles, or provides information that could assist in proper vehicle service. The procedures should not be performed by "do-it-yourselfers". Do not assume that a condition described affects your car or truck. Contact a Ford or Lincoln dealership to determine whether the Bulletin applies to your vehicle. Warranty Policy and Extended Service Plan documentation determine Warranty and/or Extended Service Plan coverage unless stated otherwise in the TSB article. The information in this Technical Service Bulletin (TSB) was current at the time of printing. Ford Motor Company reserves the right to supersede this information with updates. The most recent information is available through Ford Motor Company's on-line technical resources.