



Service Bulletin

Bulletin No.: 17-NA-040

Date: November, 2021

TECHNICAL

Subject: Brake Squeal or Squeak Noise Intermittently on Initial Brake Applies

Brand:	Model:	Model Year:		VIN:		Engine:	Transmission:
		from	to	from	to		
Buick	Regal GS	2013	2020	—		All	All
Cadillac	ATS	2013	2019	—		All	All
	XTS						
	CTS (VIN A)	2014					
	ATS-V	2016					
	CTS-V						
CT6	2020						
Chevrolet	Corvette	2014	2022	—		All	All
	SS	2014	2017				

Involved Region or Country	North America, Japan, Europe, Russia, Middle East, China, Iraq, Israel, Palestine, Cadillac Korea (South Korea), Thailand
Condition	Some customers may comment on a squeal or squeak noise from the front brakes. This condition normally only occurs on initial brake applications after the vehicle has sat for an extended time. The condition occurs typically under light braking, in speeds under 16 km/h (10 mph). After 1-6 brake applies, or after braking at higher speeds, the noise no longer occurs. This condition may occur more often in high humidity conditions.
Correction	Apply a coat of copper paste to completely cover the pad backing plate abutments on each end.

Service Procedure

Important: The use of wheel cleaners or power washers directly pointed at the brake caliper may wash the copper paste off of the brake pads. It may be necessary to apply the copper paste again if the lubricant is washed away. The copper paste should be applied whenever the brake pads are removed or replaced.

Apply a coat of copper paste to completely cover the pad backing plate abutments on each end. The paste should not extend onto the friction material. Follow the instructions listed below.

Buick Regal

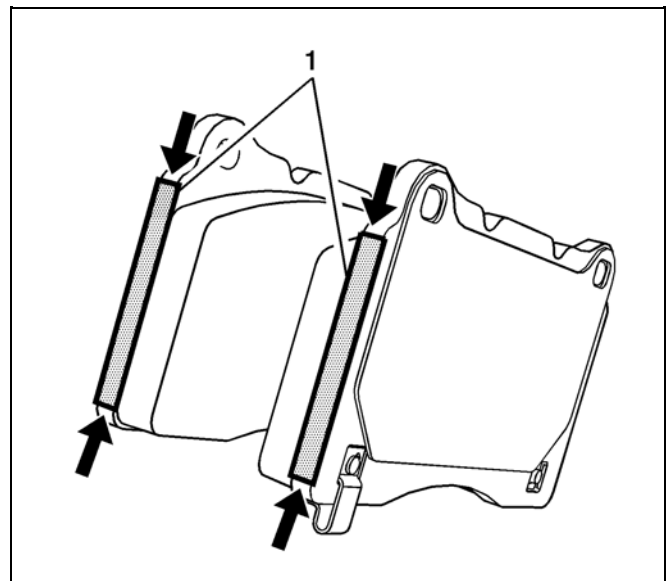

3326987

Legend

(1) Abutment Area

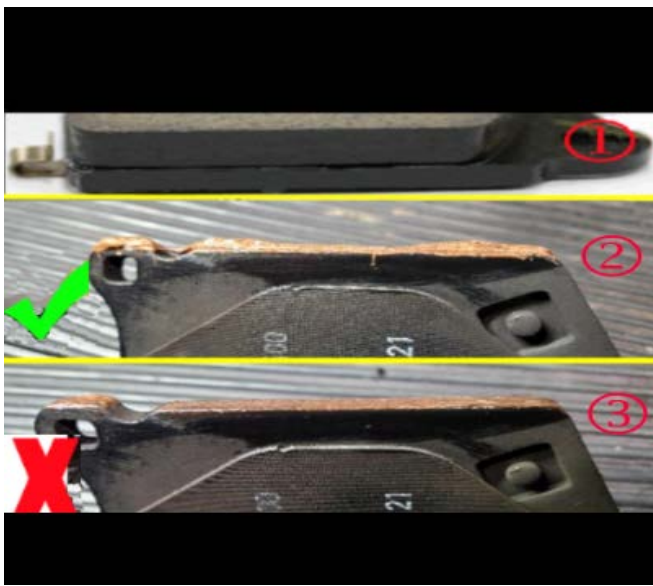

5926095

Legend

- (1) Cleaned Abutment Area
- (2) Correct Amount of Copper Paste
- (3) Incorrect Amount of Copper Paste

1. Remove the front disc brake pads. Refer to *Front Disc Brake Pads Replacement* in SI.
2. Using acrysol Kent Industries Part# P2005 or equivalent, wipe clean both ends of the abutment area on the front pads and calipers.
3. Apply approximately 0.10 g (0.0035 oz) of copper paste to each end of the disc brake pad abutments that contact the brake caliper bracket.

Note: Avoid a light apply of the paste as illustrated above.

4. Re-install the front disc brake pads. Refer to *Front Disc Brake Pads Replacement* in SI.

Cadillac Models and Chevrolet Models

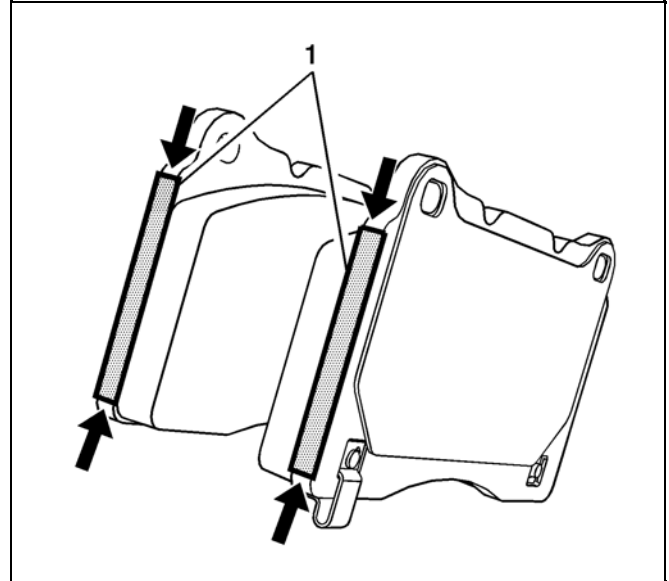

3326987

Legend

(1) Abutment Area

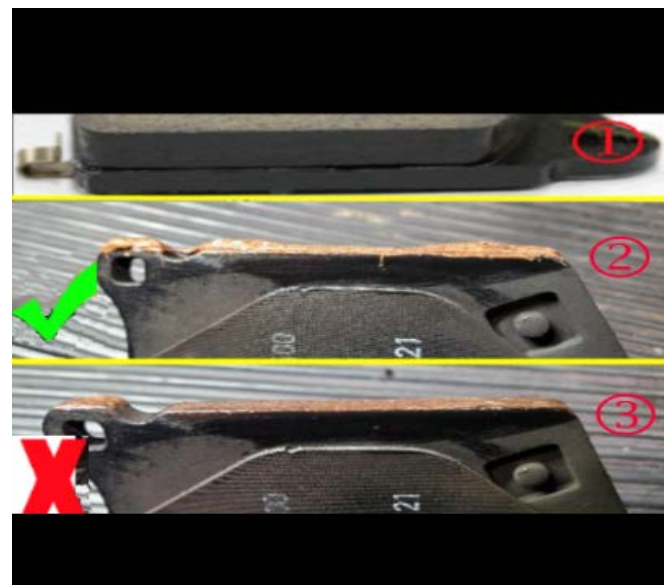

5926095

Legend

- (1) Cleaned Abutment Area
- (2) Correct Amount of Copper Paste
- (3) Incorrect Amount of Copper Paste

1. Remove the front disc brake pads. Refer to *Front Disc Brake Pads Replacement* in SI.
2. Remove the rear disc brake pads. Refer to *Rear Disc Brake Pads Replacement* in SI.

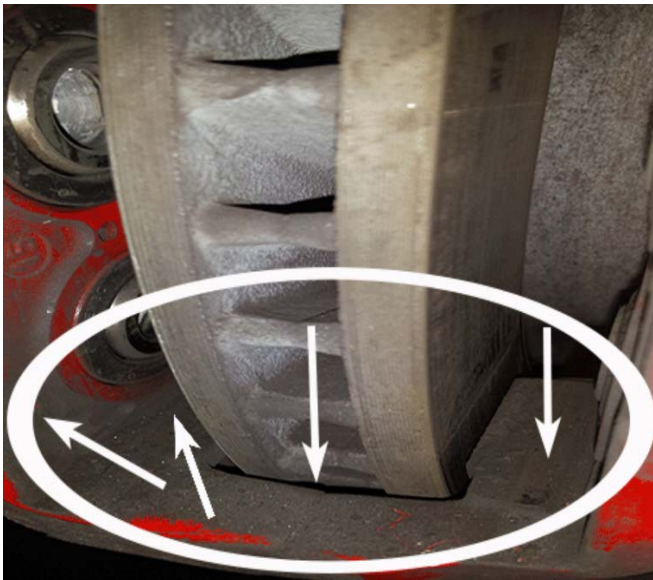

4337633

3. Using acrysol Kent Industries Part# P2005 or equivalent, wipe clean both ends of the abutment area on the front and rear pads and calipers.
4. Apply approximately 0.10 g (0.0035 oz) of copper paste to each end of the disc brake pad abutments that contact the brake caliper bracket.

Note: Ensure that the ends of the brake pads have enough copper paste applied, if not, could result of the noise condition returning.



4364263



4364283

5. (Chevrolet SS Models Only) Apply a rectangular shape of copper paste in the center of the spacer before installing on the back of the pad.

Note: DO NOT replace brake pads for this condition.

6. Re-install the front disc brake pads. Refer to *Front Disc Brake Pads Replacement* in SI.



4337814

Important: DO NOT remove the silencers (1) on the pads.

Important: Always replace brake pads with Brembo GM OEM pads (2). Aftermarket pads could result in the braking performance changing in many ways.

7. Re-install the rear disc brake pads. Refer to *Rear Disc Brake Pads Replacement* in SI.

Parts Information

For Export Regions that may not be able to obtain the part numbers below, please use an appropriate equivalent.

Description	Part Number	Qty
Lubricant	19303310 (In Canada, use 19303311)	3

Warranty Information

For vehicles repaired under the Bumper-to-Bumper coverage (Canada Base Warranty coverage), use the following labor operation. Reference the Applicable Warranties section of Investigate Vehicle History (IVH) for coverage information.

Labor Operation	Description	Labor Time
2480038*	Cleaning and Reapplying Lubricant to Front Disc Brake Pads	2020–2022 Corvette RPO J55 Brakes - 1.0 hr All Other Models – 0.6 hr
Add	Cleaning and Reapplying Lubricant to Rear Disc Brake Pads	0.4 hr

*This is a unique Labor Operation for bulletin use only.

Version	8
Modified	<p>March 6, 2017 – Added the Cadillac CT6 model.</p> <p>March 17, 2017 – Removed an Important statement from Service Procedure.</p> <p>November 30, 2018 – Added the 2018 and 2019 Model Years.</p> <p>August 11, 2020 – Added the 2020 Corvette Model, updated the Involved Region or Country section, added an Export region statement to the Parts Information and relocated the Parts Information and Warranty Information sections.</p> <p>December 18, 2020 – Added the 2020 CT6 Model and updated the Involved Region or Country section.</p> <p>August 27, 2021 – Added the 2020 Model Year to Regal, 2021 Model Year to Corvette and updated the Involved Region or Country section.</p> <p>November 17, 2021 – Added the 2022 Model Year to Corvette, updated two graphics showing copper paste and updated Warranty Information with new Labor Time for 2020–2022 Corvette with RPO J55 Brakes.</p>

