



Service Bulletin

Bulletin No.: 19-NA-129

Date: September, 2021

TECHNICAL

Subject: Squeak and/or Clunking Noise from Rear of Vehicle

Brand:	Model:	Model Year:		Date Breakpoint:		Engine:	Transmission:
		from	to	from	to		
Chevrolet	Silverado 1500 (New Model)					All	All
	Silverado 1500 (New Model - 12th VIN Digit = 7) - 4WD	2019	2019				
GMC	Sierra 1500 (New Model)						
Chevrolet	Silverado 1500	2020	2020				
GMC	Sierra 1500						

is the close paren in the right place?

Involved Region or Country	North America, Middle East, Paraguay, Uruguay, Chile and Thailand
Condition 1	Some customers may comment on a squeak type noise heard from the rear of the vehicle. Upon further investigation, the technician may diagnose the noise is coming from the rear suspension leaf spring area.
Condition 2	Some customers may comment on a clunking type noise heard from the rear of the vehicle. Upon further investigation, the technician may diagnose the noise is coming from the rear suspension leaf spring area.
Cause	This condition may be caused by debris getting between the leaf springs and/or loose U-Bolts.
Correction 1	Note: 2020 vehicles built at Silao after March 17, 2020, or built at Fort Wayne after June 11, 2020 are possible candidates for torque relaxation at the U-bolt to axle and the 1610 km (1000 miles) break-in period, but should NOT have new inserts installed. The service inserts are the same as the production inserts. For earlier built vehicles, install new rear leaf spring inserts, following the Service Procedure below.
Correction 2	Note: Vehicles built after the 2020 breakpoints noted above, may still have torque relaxation at the U-bolt to axle and should have the re-torque performed. Re-torque the U-bolts of the leaf spring assembly, following the Service Procedure below.

Service Procedure (Condition 1)

Prior to performing this bulletin, follow the procedure for Noise Diagnosis - Rear Suspension in SI to determine the source of the noise. Jounce the rear of the vehicle utilizing J 39570 Chassis Ear or equivalent, to aid in locating the source of the noise.

If necessary, road test the vehicle.

1. Raise the vehicle on a frame lift-type hoist. Refer to *Lifting and Jacking the Vehicle*, in SI.
2. Inspect the rear leaf springs and shackles for damage.
 - If damage has been found, refer to *Rear Spring Shackle Replacement or Leaf Spring Replacement (1500)*, in SI.
 - If damage has NOT been found, proceed to the next step.



5341853



5341854

3. Install new Rear Leaf Spring Inserts using the following procedure:
 - 3.1. Clean the springs using high-pressure water or a steam cleaner to remove any lubricant or contamination from between the leaf elements, paying special attention to the tip contact areas.

Caution: Do NOT damage the finish on Leaf Springs.

- 3.2. On the spring assembly, insert a plastic trim tool or plastic wedge in between the #1 and #2 leaf springs, to access the old insert.



5341855

- 3.3. Push up on insert until it hits the bottom of the spring above it. Then use a suitable cutting tool to cut the stem off from the insert.

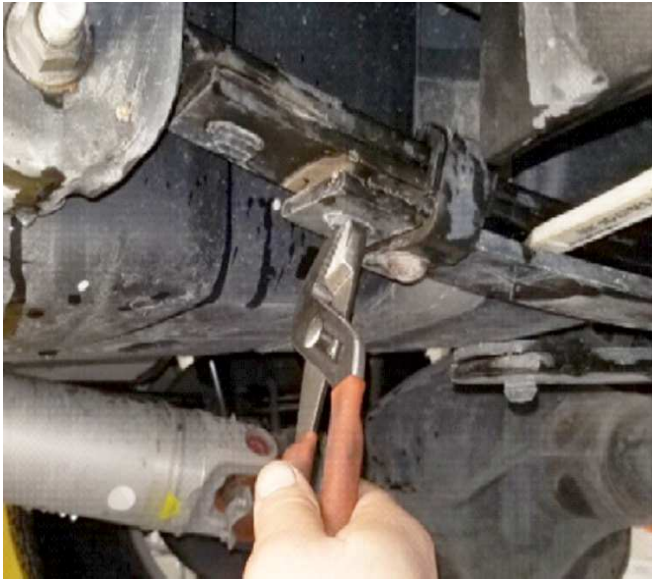

5341856

- 3.4. Remove the top portion of the insert, and then remove the bottom portion of the remaining stem.



5341859

Caution: Do NOT damage the surface of the new insert when trimming.

- 3.6. Cut the stem of the new insert with a hacksaw or suitable cutting tool. Make sure to leave 6 mm (0.240 in) of the stem.



5341857

- 3.5. Using a rag and degreaser, clean any dirt or grease from between the leaf springs at the insert location.

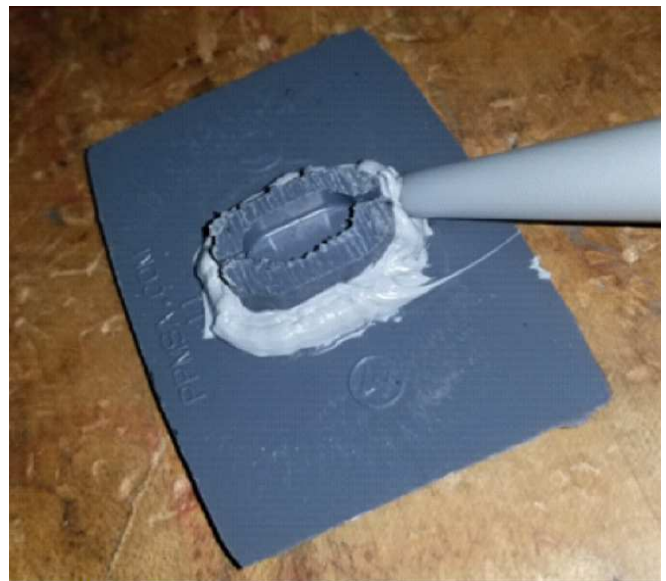

5341861

- 3.7. Apply a small amount of RTV sealer around the remaining portion of the stem.
- 3.8. Install the new insert into the leaf spring. Make sure the stem portion lines up with the slot in the spring. Remove the plastic trim tool or plastic wedge to close the spring and seat the new insert.

- Repeat step #3 for the 3 remaining inserts.

Important: After a new vehicle is delivered to a customer, or new spring tip inserts are installed per this bulletin, new inserts have a break-in period of up to 1610 km (1000 miles), where some noise can be expected.

The gray spring inserts are designed to work with absolutely no lubricant. Lubricants of any kind must never be used on the gray spring tip inserts and any remaining lubricant must be completely removed when installing new tip inserts.

- Lower the vehicle to the ground and test drive to verify the repair.

Note: If the vehicle returns with noise after this procedure, and there is no loss of torque at the U-Bolts, thoroughly clean the spring contact points with high pressure water or a steam cleaner to remove contaminants from between the spring elements. Contaminants, grease, undercoating or any substance in the leaf interface will cause noise when the spring elements move over each other.

Important: If the Spring Tip Inserts have been replaced and 1000 miles (1610 km) has not elapsed, proceed to Service Procedure (Condition 2).

Service Procedure (Condition 2)

- Support the vehicle at curb height to relieve the tension on the leaf springs, when re-torquing the leaf spring U-bolt nuts.

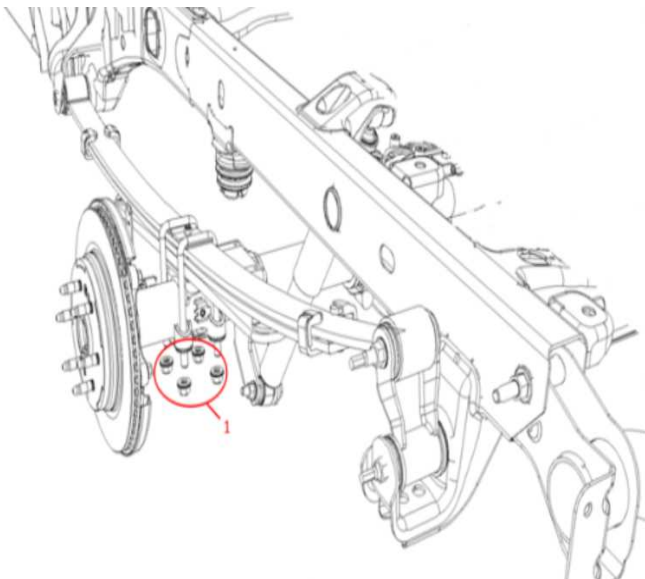

5357922

- Loosen the anchor plate U-bolts (1).

Caution: Ensure that the proper torque procedure for the U-Bolts is followed in SI. Excessive fastener torque will extrude, and damage, the spring isolators making the condition worse.

- Re-torque the anchor plate U-bolts (1). Refer to Fastener Specifications in SI.
- Repeat steps # 2 and 3 for the opposite side leaf spring.
- Re-test the vehicle for the same clunking noise. If the issue remains, follow the regular repair procedure.

Parts Information

Causal Part	Description	Part Number	Qty
N/A	INSERT-RR SPR LEAF	84855893	4
	RTV Sealer	88864346 (In Canada, 88861418)	1

Warranty Information

For vehicles repaired under the Bumper-to-Bumper coverage (Canada Base Warranty coverage), use the following labor operation. Reference the Applicable Warranties section of Investigate Vehicle History (IVH) for coverage information.

Labor Operation	Description	Labor Time
8080598*	Replacement of 4 Rear Leaf Spring Inserts (Condition 1)	0.5 hr.
8080608*	Retorque U-Bolts / Road Test (Condition 2)	0.6 hr.

*This is a unique Labor Operation for Bulletin use only.

Version	5
Modified	<p>Released August 06, 2019</p> <p>Revised March 02, 2020 – Added 2019 Silverado 1500 (New Model - 12th VIN Digit = 7) - 4WD model and 2020 Model Year, Added Breakpoint and Updated Insert Part Number.</p> <p>Revised February 08, 2021 – Updated Breakpoints, Separated Repair Procedures to Address Condition #1 and Condition #2, Updated Warranty Information.</p> <p>Revised May 05, 2021 – Added 2021 Model Year, Information to Clarify the Breakpoint Strategy and to Emphasize that the Inserts (GM P/N 84855893) Have a Break-in Period of Approximately 1610 km (1000 miles).</p> <p>Revised August 30, 2021 – Removed 2021 Model Year and all 2021 Model Year references.</p>

