



TECHNICAL SERVICE BULLETIN

Water Dripping Into The Front Passenger Side Footwell When A/C Is Operating - Built On Or After 01-Feb-2013

21-2379

28 October
2021

This bulletin supersedes 20-2382. Reason for update: Not Applicable

Model:

Ford 2014-2020 Transit Connect

Summary

This article supersedes TSB 20-2382 to update the warranty causal part.

Issue: Some 2014-2020 Transit Connect vehicles built on/or after 01-Feb-2013 may exhibit water dripping into the passenger front footwell. This may be due to an excessive gap in the heating, ventilation, and air conditioning (HVAC) case allowing water to drip from the case when the air conditioning (A/C) is operating. To correct the condition, follow the Service Procedure steps to reseal the HVAC case.

Action: Follow the Service Procedure steps to correct the condition on vehicles that meet all of the following criteria:

- 2014-2020 Transit Connect
- Built on or after 01-Feb-2013
- Water dripping from the passenger side HVAC case onto the footwell when the A/C is operating

Parts

Service Part Number	Quantity	Description
Obtain Locally	As Needed	Butyl Tape, 3M® Part Number 08612 Or Equivalent

As Needed indicates the amount of the part may vary or is not a whole number; parts can be billed out as non-whole numbers, including less than 1.

Warranty Status: Eligible under provisions of New Vehicle Limited Warranty (NVLW)/Service Part Warranty (SPW)/Special Service Part (SSP)/Extended Service Plan (ESP) coverage. Limits/policies/prior approvals are not altered by a TSB. NVLW/SPW/SSP/ESP coverage limits are determined by the identified causal part and verified using the OASIS part coverage tool.

Labor Times

Description	Operation No.	Time
2014-2020 Transit Connect: Install Butyl Tape Following The Service Procedure (Do Not Use With Any Other Labor Operations Outside Of This Article)	212379A	0.8 Hrs.
2014-2020 Transit Connect: Additional Time To Service Carpet For Dampness And/Or Odor (Can Be Claimed With Operations A)	MT212379	Actual Time

Repair/Claim Coding

Causal Part:	19B555
Condition Code:	01

Service Procedure

1. Is the concern as shown in Figure 1, water dripping onto the trim panel, or Figure 2, water dripping onto the floor covering?

- (1). Yes - proceed to Step 2.

(2). No - this article does not apply. Refer to Workshop Manual (WSM), Section 412-00 for further diagnostics.

Figure 1



E347148

Figure 2



E347149

2. Position the selector lever into drive (D).

3. Remove the selector lever bezel. Refer to WSM, Section 307-05 (Figure 3)

Figure 3

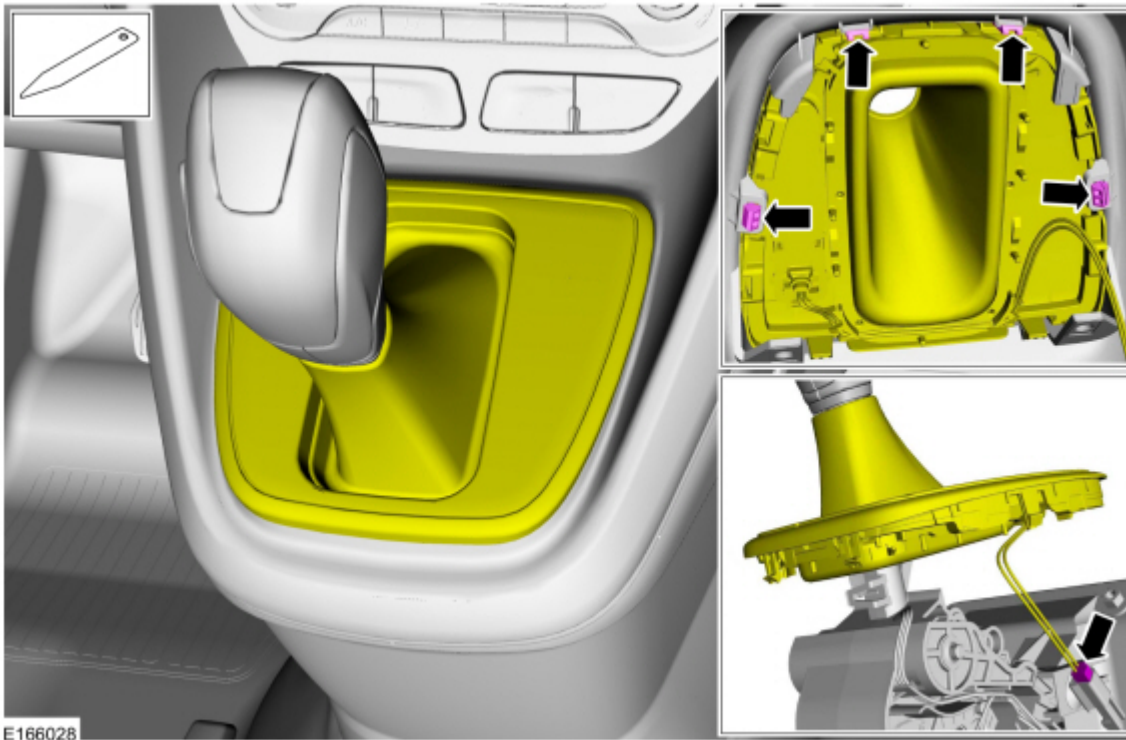

4. Remove the gearshift housing upper cover. Refer to WSM, Section 307-05. (Figure 4)

Figure 4

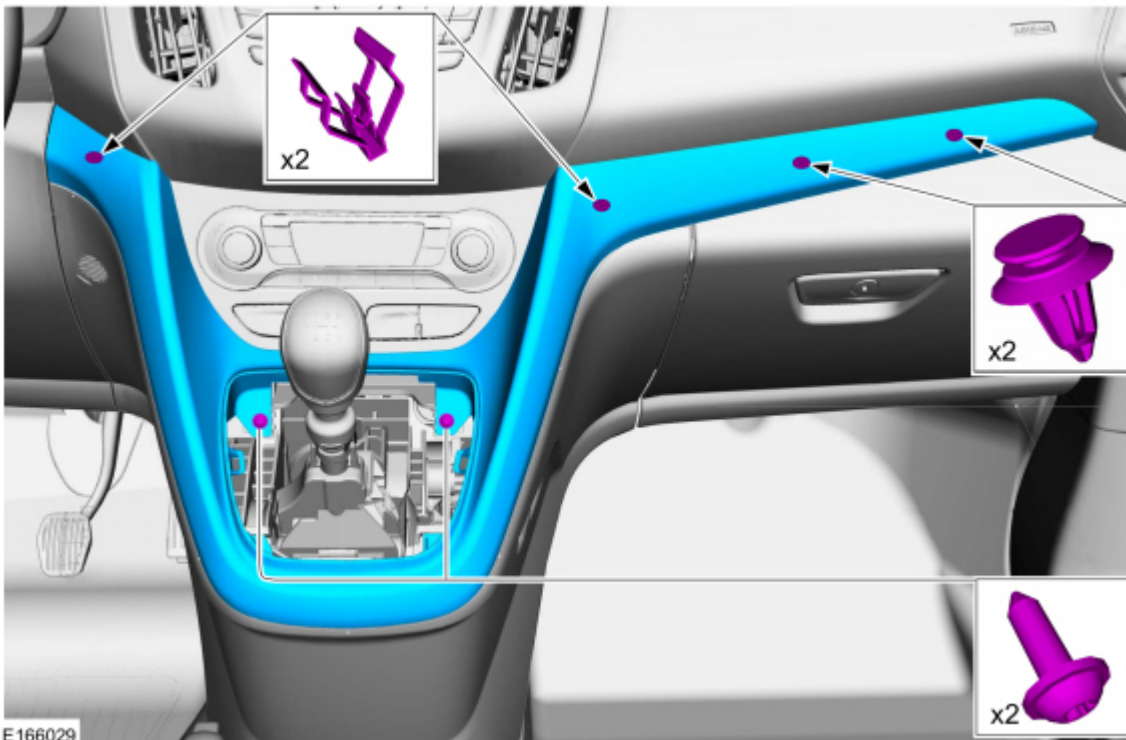

5. Remove the floor console. Refer to WSM, Section 501-12. (Figure 5)

Figure 5

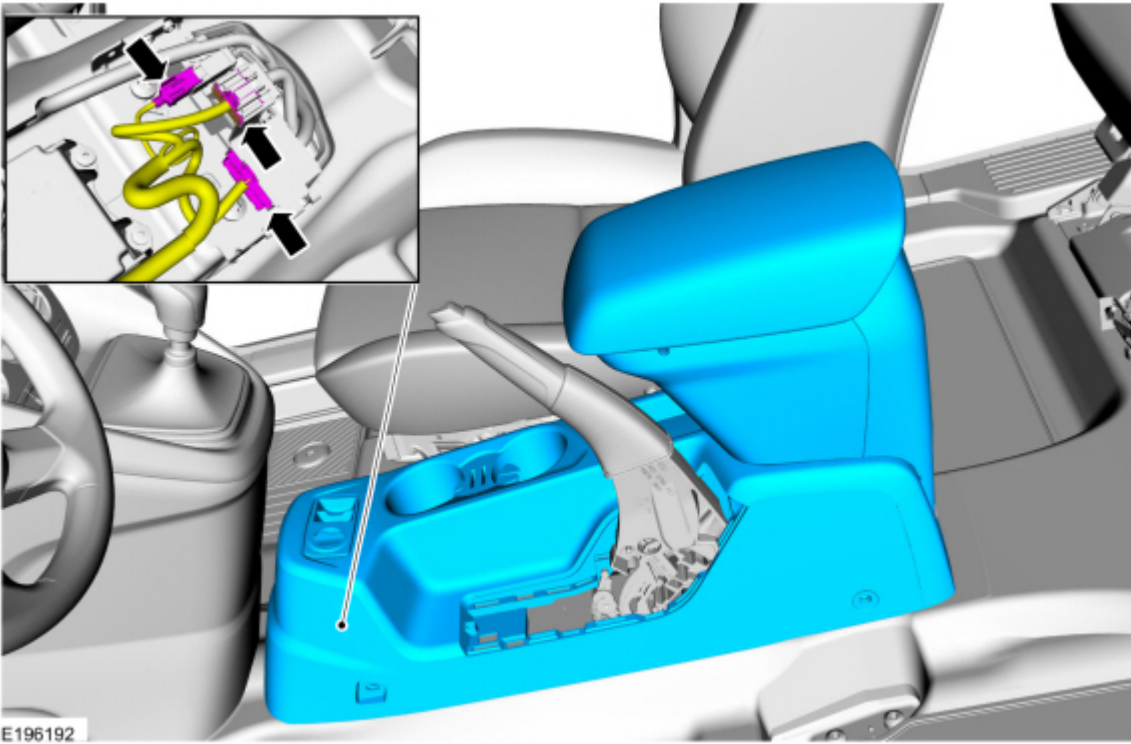

6. Remove the gearshift housing lower cover. Refer to WSM, Section 307-05. (Figure 6)

Figure 6

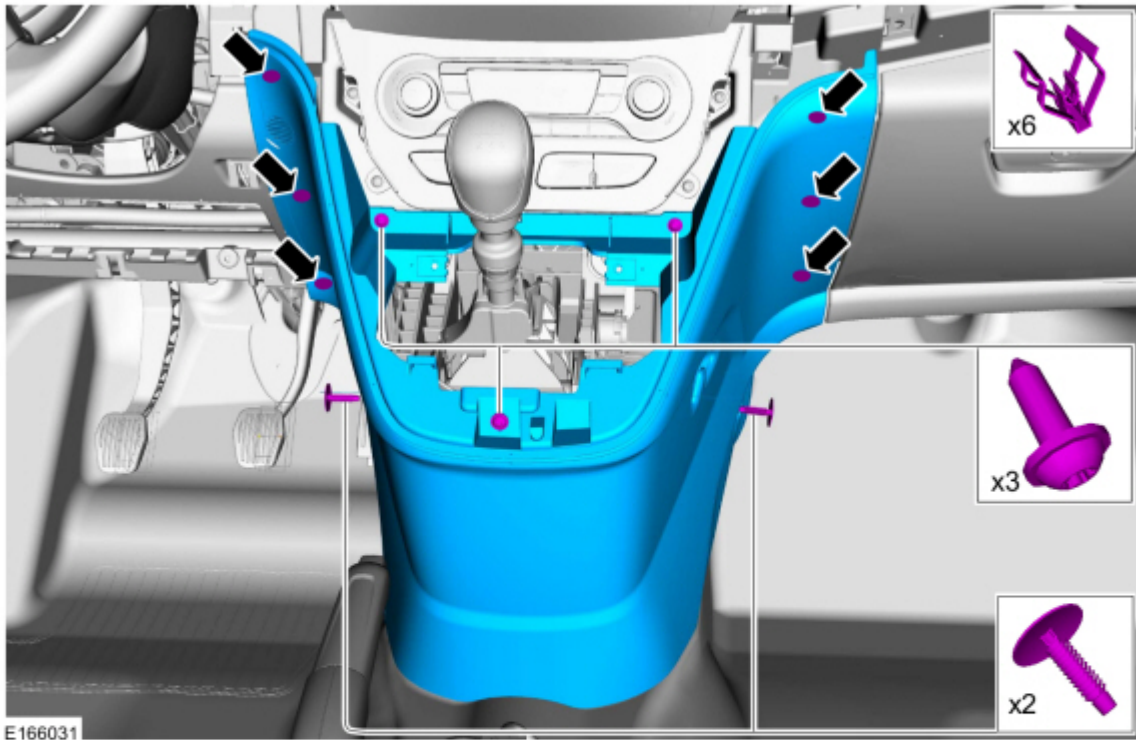

7. Position the carpet aside to access the cover screw and cover, if equipped.

8. Remove the cover, if equipped. (Figure 7)

Figure 7



9. Obtain butyl tape.

10. Press the butyl tape into the groove of the evaporator cover.

(1). Cut a piece of butyl tape to cover the area shown in Figure 8.

(2). Press the butyl tape around front/rear corner and into the hole. (Figure 8)

Figure 8



11. To install, reverse the removal procedure.

© 2021 Ford Motor Company

All rights reserved.

NOTE: The information in Technical Service Bulletins is intended for use by trained, professional technicians with the knowledge, tools, and equipment to do the job properly and safely. It informs these technicians of conditions that may occur on some vehicles, or provides information that could assist in proper vehicle service. The procedures should not be performed by "do-it-yourselfers". Do not assume that a condition described affects your car or truck. Contact a Ford or Lincoln dealership to determine whether the Bulletin applies to your vehicle. Warranty Policy and Extended Service Plan documentation determine Warranty and/or Extended Service Plan coverage unless stated otherwise in the TSB article. The information in this Technical Service Bulletin (TSB) was current at the time of printing. Ford Motor Company reserves the right to supersede this information with updates. The most recent information is available through Ford Motor Company's on-line technical resources.