



Service Bulletin

PRELIMINARY INFORMATION

Subject: Brake Squeal or Squeak Noise Intermittently on Initial Brake Applies

Models: 2013-2016 Buick Regal GS
2014-2016 Chevrolet Corvette, Chevrolet SS

Attention: This PI also applies to any of the above models that may be Export vehicles.

This PI has been revised to add the 2014-2015 Corvette and Chevrolet SS and also update information under Recommendation/Instructions and Warranty Information. Please discard PI1496.

Condition/Concern

Some customers may comment on a squeal or squeak noise from the front brakes. This condition normally only occurs on initial brake applications after the vehicle has sat for an extended time. The condition occurs typically under light braking, in speeds under 16km/h (10 mph). After 1-6 brake applies, or after braking at higher speeds, the noise no longer occurs. This condition may occur more often in high humidity conditions.

Recommendation/Instructions

Important: Do not apply the copper paste to the back of the backing plate.

Apply a coat of copper paste to completely cover the pad backing plate abutments on each end. The paste should not extend onto the friction material. Follow the instructions listed below.

Buick Regal

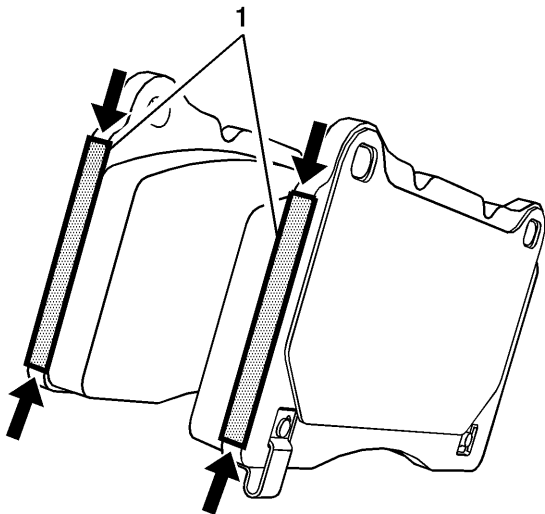

1. Abutment Area

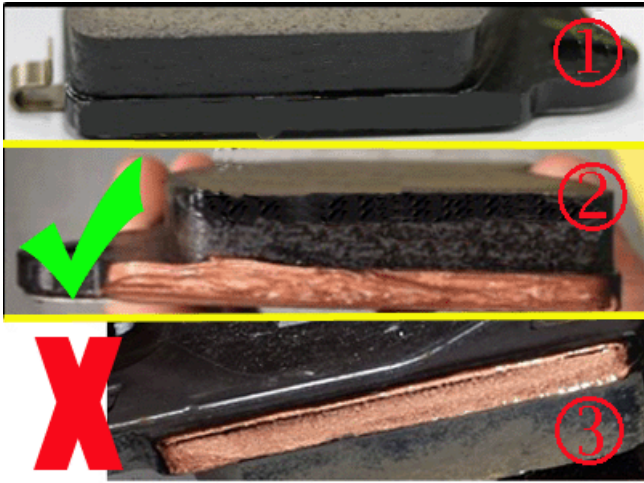

1. *Cleaned Abutment Area*
2. *Correct Amount of Copper Paste*
3. *Incorrect Amount of Copper Paste*

1. Remove the front disc brake pads. Refer to the Front Disc Brake Pads Replacement in SI.
2. Using acrysol Kent Industries Part# P2005 or equivalent, wipe clean both ends of the abutment area on the front pads and calipers.
3. Apply approximately 0.10 g (0.0035 oz) of copper paste to each end of the disc brake pad abutments that contact the brake caliper bracket.

Note: Avoid a light apply of the paste as illustrated above.
4. Re-install the front disc brake pads. Refer to the Front Disc Brake Pads Replacement in SI.

Chevrolet SS / Corvette

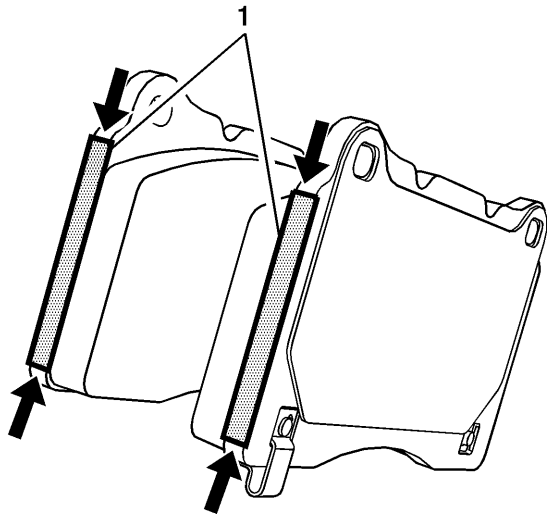

1. *Abutment Area*

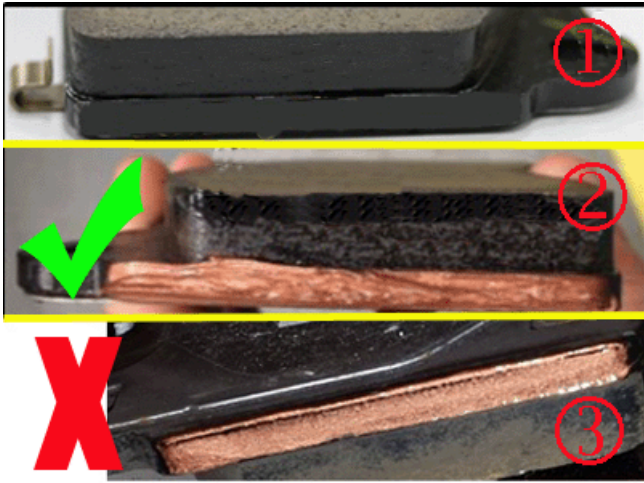

1. *Cleaned Abutment Area*
2. *Correct Amount of Copper Paste*
3. *Incorrect Amount of Copper Paste*

1. Remove the front disc brake pads. Refer to the Front Disc Brake Pads Replacement in SI.
2. Remove the rear disc brake pads. Refer to the Rear Disc Brake Pads Replacement in SI.

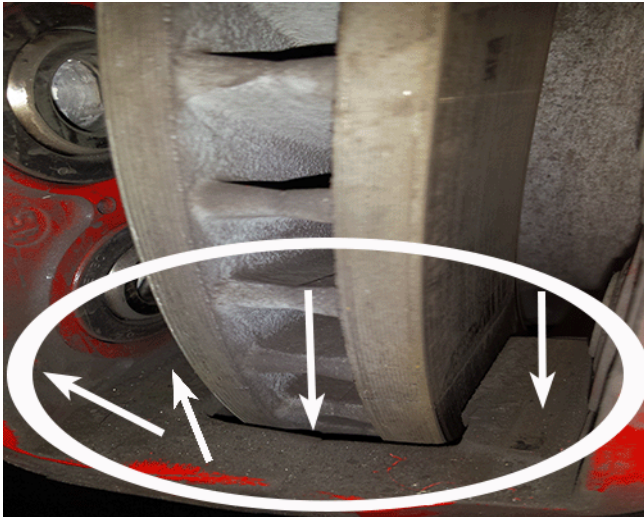

3. Using acrysol Kent Industries Part# P2005 or equivalent, wipe clean both ends of the abutment area on the front and rear pads and calipers.
4. Apply approximately 0.10 g (0.0035 oz) of copper paste to each end of the disc brake pad abutments that contact the brake caliper bracket.

Note: **DO NOT** apply copper paste on the back side of the brake pad. Example shown of a brake pad that had the copper paste applied on the back side from the plant.

Note: Avoid a light apply of the paste as illustrated above.
5. Re-install the front disc brake pads. Refer to the Front Disc Brake Pads Replacement in SI.



Important: DO NOT remove the silencers (1) on the pads.

Important: Always replace brake pads with Brembo GM OEM pads (2). Aftermarket pads could result in the braking performance changing in many ways.

6. Re-install the rear disc brake pads. Refer to the Rear Disc Brake Pads Replacement in SI.

Parts Information

Part Number	Description	Qty
19303310 (In Canada, use 19303311)	Lubricant	2

Warranty Information

For vehicles repaired under the Bumper-to-Bumper coverage (Canada Base Warranty coverage), use the following labor operation. Reference the Applicable Warranties section of Investigate Vehicle History (IVH) for coverage information.

Labor Operation	Description	Labor Time
2480038*	Cleaning and Reapplying Lubricant to Front Disc Brake Pads	0.6 hr
Add	Cleaning and Reapplying Lubricant to Rear Disc Brake Pads	0.2 hr

*This is a unique Labor Operation for Bulletin use only. It will not be published in the Labor Time Guide.

GM bulletins are intended for use by professional technicians, NOT a "do-it-yourselfer". They are written to inform these technicians of conditions that may occur on some vehicles, or to provide information that could assist in the proper service of a vehicle. Properly trained technicians have the equipment, tools, safety instructions, and know-how to do a job properly and safely. If a condition is described, DO NOT assume that the bulletin applies to your vehicle, or that your vehicle will have that condition. See your GM dealer for information on whether your vehicle may benefit from the information.



WE SUPPORT VOLUNTARY TECHNICIAN CERTIFICATION