

ATTENTION:
 GENERAL MANAGER
 PARTS MANAGER
 CLAIMS PERSONNEL
 SERVICE MANAGER

IMPORTANT - All Service Personnel Should Read and Initial in the boxes provided, right.

© 2021 Subaru of America, Inc. All rights reserved.



QUALITY DRIVEN® SERVICE

SERVICE BULLETIN

APPLICABILITY: 2018-21MY Outback

NUMBER: 12-318-21

SUBJECT: Rear Bumper Reflex Reflector- Design Change

DATE: 04/08/21

INTRODUCTION:

This bulletin outlines a design change to the rear bumper “Reflex Reflectors” made to enhance their retention into the bumper cover as shown in the photos below.

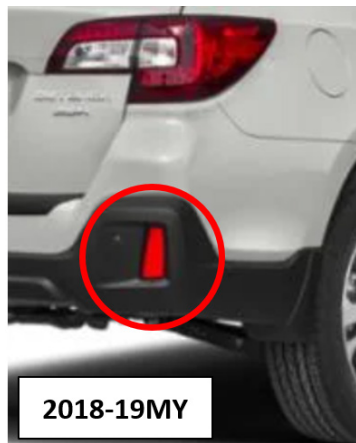

PRODUCTION CHANGE INFORMATION:

The new-design reflector assemblies were incorporated into production starting with VIN **M3183715**.

PART INFORMATION:

Description	Part Number
REFLEX REFLECTOR ASSY- RIGHT	84281AL02A
BRKT COVER- RIGHT	84927AN06A
FLANGE NUT (qty. 1 per side)	902370044
REFLEX REFLECTOR ASSY- LEFT	84281AL03A
BRKT COVER-LEFT	84927AN07A

CAUTION: VEHICLE SERVICING PERFORMED BY UNTRAINED PERSONS COULD RESULT IN SERIOUS INJURY TO THOSE PERSONS OR TO OTHERS.

Subaru Service Bulletins are intended for use by professional technicians ONLY. They are written to inform those technicians of conditions that may occur in some vehicles, or to provide information that could assist in the proper servicing of the vehicle. Properly trained technicians have the equipment, tools, safety instructions, and know-how to do the job correctly and safely. If a condition is described, DO NOT assume that this Service Bulletin applies to your vehicle, or that your vehicle will have that condition.

Subaru of America, Inc. is ISO 14001 Compliant

ISO 14001 is the international standard for excellence in Environmental Management Systems. Please recycle or dispose of automotive products in a manner that is friendly to our environment and in accordance with all local, state and federal laws and regulations.

Continued...

The new part utilizes an added retaining bracket combined with a stud and nut arrangement to supplement the “claw” (or snap-in) retention design.

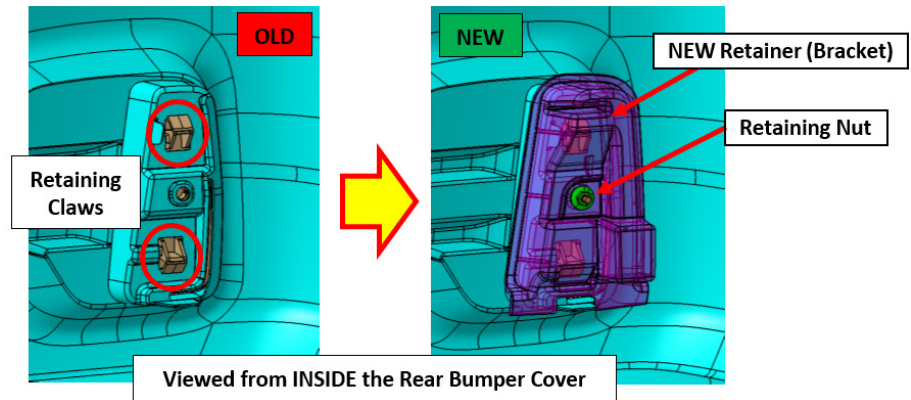

REMINDER: Always order the most up-to-date replacement parts based on the specific VIN being repaired.

SERVICE PROCEDURE / INFORMATION:

REMINDERS: Customer satisfaction and retention starts with performing quality repairs. Always refer to STIS and review the full requirements of the repair being performed. The Service Manual procedures contain information critical to performing an effective repair the first time, every time.

2020-21MY OUTBACK WITH Reverse Automatic Braking (RAB):

- 1) **CAREFULLY** remove the RAB harness retaining clip from the bumper cover.
- 2) Fit the new reflector assembly to the bumper making sure the retaining claws are fully seated.
- 3) Install the new bracket from the inside of the bumper cover as shown while paying close attention to not pinch the RAB harness between the bracket and the bumper cover.
- 4) Install the retaining flange nut and torque to 40 inch-pounds.
- 5) Re-secure the RAB harness to the bumper cover with the clip removed in 1) above.

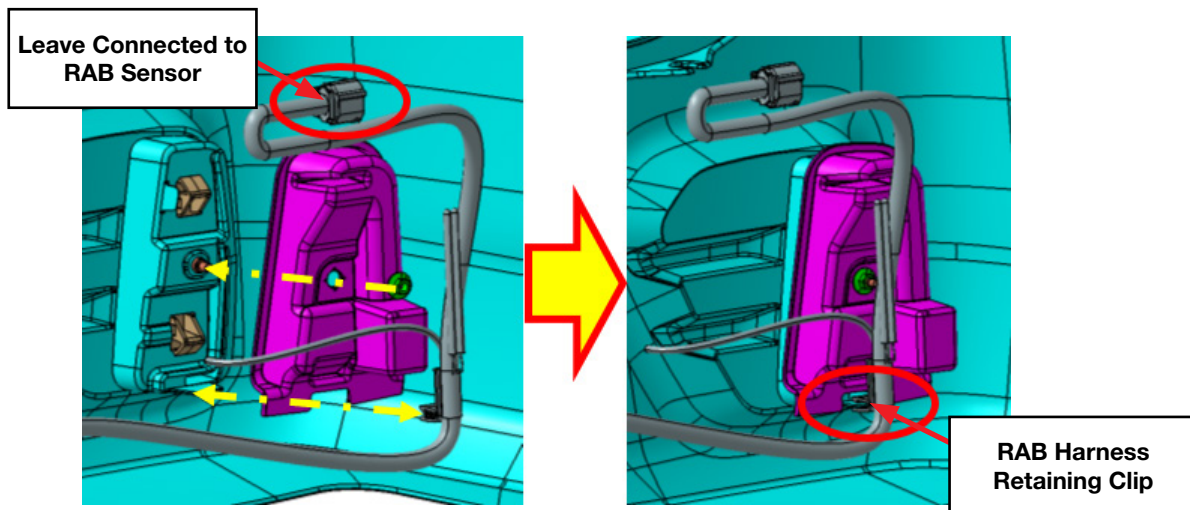

Continued...

2020-21MY OUTBACK WITHOUT RAB:

- 1) Fit the new reflector assembly to the bumper making sure the retaining claws are fully seated.
- 2) Install the new bracket from the inside of the bumper cover as shown.
- 3) Install the retaining flange nut and torque to 40 inch-pounds.

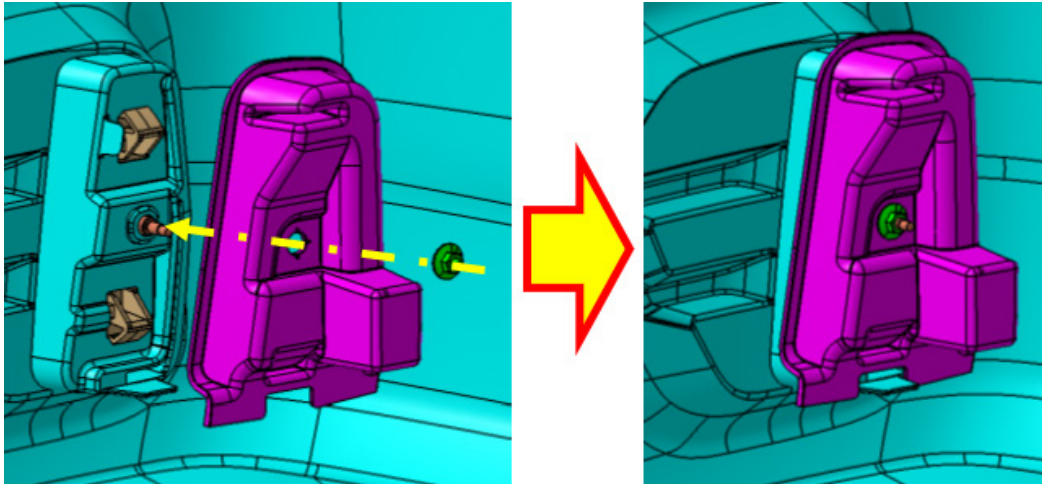

2018-19MY OUTBACK WITH RAB:

- 1) Fit the new reflector assembly to the bumper making sure the retaining claws are fully seated.
- 2) Install the new bracket from the inside of the bumper cover as shown while paying close attention to not pinch the RAB harness between the bracket and the bumper cover.
- 3) Install the retaining flange nut and torque to 40 inch-pounds.

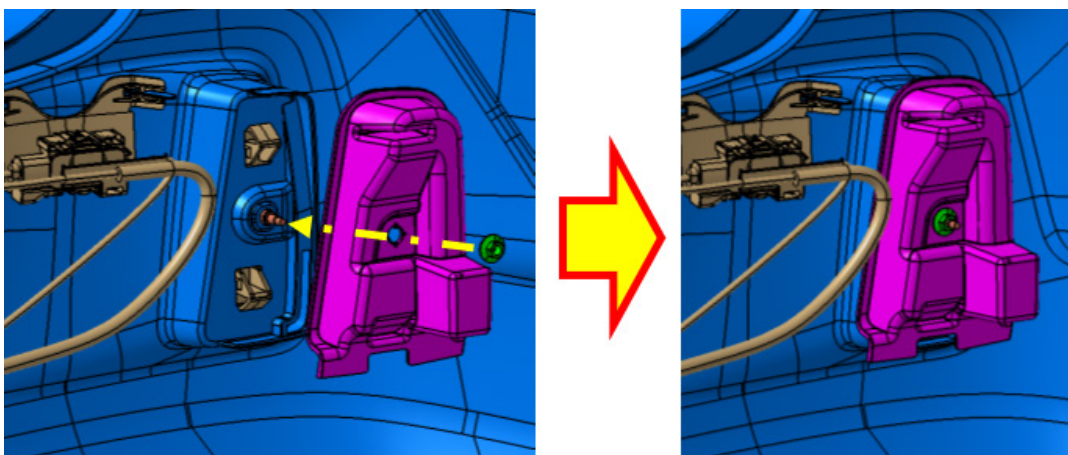

Continued...

2018-19MY OUTBACK WITHOUT RAB:

- 1) Fit the new reflector assembly to the bumper making sure the retaining claws are fully seated.
- 2) Install the new bracket from the inside of the bumper cover as shown.
- 3) Install the retaining flange nut and torque to 40 inch-pounds.

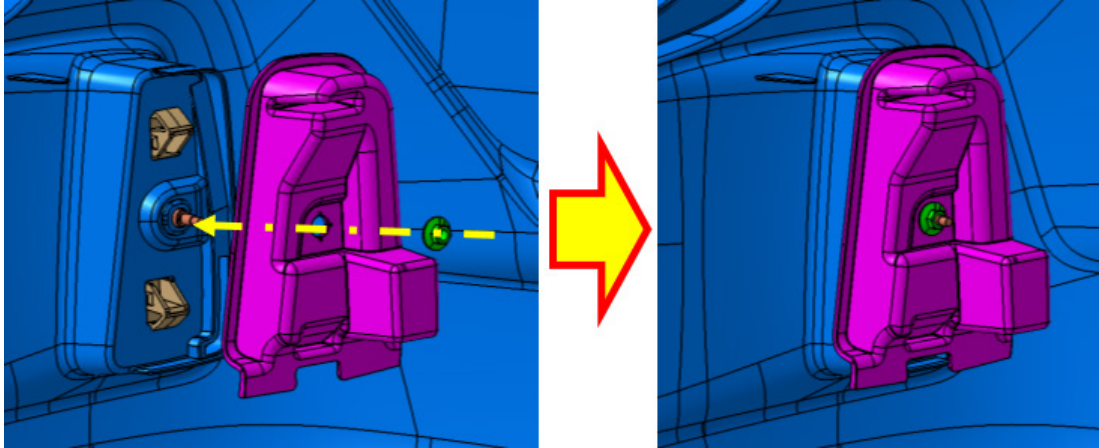

WARRANTY / CLAIM INFORMATION:

For vehicles within the Basic New Car Limited Warranty period, this repair may be submitted using the following claim information:

Labor Description	Labor Operation #	Labor Time	Fail Code
REAR BUMPER REFLECTOR ASSY. R&R ONE or BOTH	A916-404	0.2	XMC-05

IMPORTANT REMINDERS:

- SOA strongly discourages the printing and/or local storage of service information as previously released information and electronic publications may be updated at any time.
- Always check for any open recalls or campaigns anytime a vehicle is in for servicing.
- Always refer to STIS for the latest service information before performing any repairs.