

ATTENTION:

- GENERAL MANAGER
- PARTS MANAGER
- CLAIMS PERSONNEL
- SERVICE MANAGER

IMPORTANT - All Service Personnel Should Read and Initial in the boxes provided, right.

© 2020 Subaru of America, Inc. All rights reserved.



QUALITY DRIVEN® SERVICE

SERVICE BULLETIN

APPLICABILITY: 2019-20MY Ascent
SUBJECT: Hood Panel Vibration

NUMBER: 12-281-20
DATE: 02/19/20

INTRODUCTION:

This bulletin provides a repair procedure to address a small number of customer concerns of the hood panel surface vibrating while driving. This condition can result if the mastic (adhesive) used to bond the inner hood reinforcing panel to the outer panel (skin) begins to separate.

REQUIRED TOOLS AND MATERIALS INFORMATION:

- 3M Panel Bonding Adhesive #08116 (200ml tube)
- 3M Mixing Nozzles #08193
- 3M Applicator #08571
- A 25 x 50 x 5mm (1" x 2" x .200 thick) non-metallic (plastic or wood) spacer with rounded edges
- Alcohol wipes (or isopropyl alcohol)
- Clean Shop Cloths
- Qty. 8: 90814FC001 Hood Insulation clips



SERVICE PROCEDURE / INFORMATION:

REMINDER: Customer satisfaction and retention starts with performing quality repairs.

The instructions supplied with the 3M adhesive product contain information critical to performing an effective repair. The product is readily available online and from most Auto Body supply outlets. Additional information is readily available on the 3M website: www.3MCollision.com. Product directions also include important SAFETY precautions and processes to follow for a complete and lasting repair.

CAUTION: VEHICLE SERVICING PERFORMED BY UNTRAINED PERSONS COULD RESULT IN SERIOUS INJURY TO THOSE PERSONS OR TO OTHERS.

Subaru Service Bulletins are intended for use by professional technicians ONLY. They are written to inform those technicians of conditions that may occur in some vehicles, or to provide information that could assist in the proper servicing of the vehicle. Properly trained technicians have the equipment, tools, safety instructions, and know-how to do the job correctly and safely. If a condition is described, DO NOT assume that this Service Bulletin applies to your vehicle, or that your vehicle will have that condition.

Subaru of America, Inc. is ISO 14001 Compliant

ISO 14001 is the international standard for excellence in Environmental Management Systems. Please recycle or dispose of automotive products in a manner that is friendly to our environment and in accordance with all local, state and federal laws and regulations.

Continued...

- Use the photos below to identify the inspection areas and determine the potential repair points.

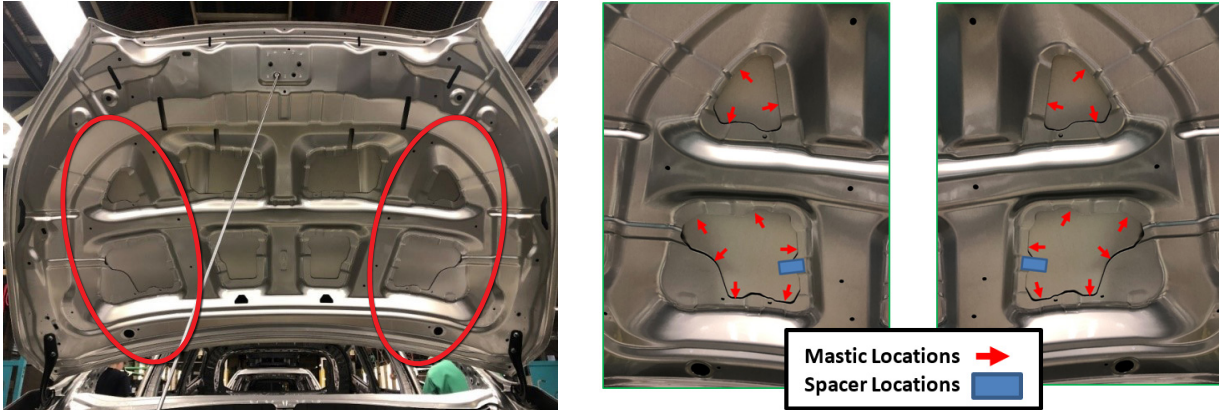

PREPARATION FOR REPAIR:

CAREFULLY remove the under hood insulation materials following the procedure in the applicable Service Manual. **NOTE:** The four (4) retaining clips (qty. 8 total) for both outer sections shown below p.n. **90814FC001** are 1-time use and **MUST** be replaced at reassembly.

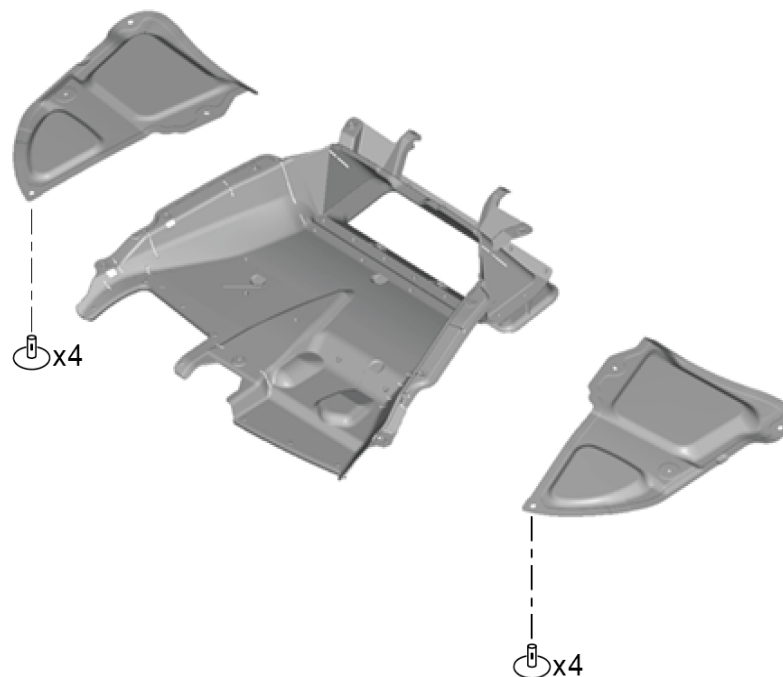

- Thoroughly clean all areas indicated in the photos above where the repair adhesive will be applied with alcohol wipes (or isopropyl alcohol on a **clean** shop cloth). All application areas must be completely free of any foreign material (grease, dirt) which could prevent proper adhesion to either panel. Always allow the alcohol to dry completely before proceeding with application of the adhesive.

Continued...

ADHESIVE APPLICATION:

- Before applying adhesive, CAREFULLY insert the spacer between the inner and outer hood panels at the location (s) indicated in the above photo on the side intended for the repair. Use two spacers if both the left and right side need to be repaired. Keep the edge of the spacer outside the gap as shown to make removal after the adhesive is cured easier.
- Using the fine point tip of the applicator nozzle, CAREFULLY apply the adhesive between the outer and inner hood panels as indicated in the photo above. Apply enough material to adhere both panels, keeping the width of the adhesive approximately 18mm (3/4in.).
- Use a clean shop cloth to wipe away any excess adhesive protruding from the edges of the application areas. Adhesive should not protrude from the edges of the inner openings after it is cured. Follow the specific 3M product instructions for the applicable cure times.
- After the adhesive is fully cured (24 hours at 73 degrees F ambient temperature), remove the spacer(s) to complete the repair.

WARRANTY / CLAIM INFORMATION:

For vehicles within the Basic New Car Limited Warranty period, this repair may be submitted using the following claim information:

Labor Description	Labor Operation #	Labor Time	Fail Code
ASCENT HOOD ADHESIVE REPAIR- ONE SIDE	A914-002	0.5	XAB-52
ASCENT HOOD ADHESIVE REPAIR- BOTH SIDES	A914-004	0.7	

NOTES:

- Up to \$60.00 can be claimed in sublet for the mixing nozzles and adhesive.
- Up to \$80.00 can be claimed ONE TIME in sublet to cover the cost of the applicator (if needed).
- This repair is eligible for 1 day of car rental expense (claimed in sublet) to allow for adhesive curing time.

IMPORTANT REMINDERS:

- SOA strongly discourages the printing and/or local storage of service information as previously released information and electronic publications may be updated at any time.
- Always check for any open recalls or campaigns anytime a vehicle is in for servicing.
- Always refer to STIS for the latest service information before performing any repairs.