



TECHNICAL SERVICE BULLETIN

Stop Safely Now Message In The IPC - Built On 15-Sep-2011 And Through 9-Dec-2015

20-2004

14 January
2020

Model:

Ford 2012-2016 Focus

Issue: Some 2012-2016 Focus Electric vehicles built on 15-Sep-2011 and through 9-Dec-2015 may exhibit a Stop Safely Now message displayed in the instrument panel cluster (IPC) message center. This may be due to either an internal coolant leak on the upper or lower high voltage battery or corrosion on the lower high voltage battery connector caused by water ingress. If this occurs, the vehicle may not restart once it has been shut off. To resolve the condition, follow the Service Procedure to replace the upper and lower high voltage battery or apply corrosion protection.

Action: Follow the Service Procedure steps to correct the condition on vehicles that meet all of the following criteria:

- 2012-2016 Focus Electric
- Built on 15-Sep-2011 and through 9-Dec-2015
- Stop Safely Now message in the IPC

Parts

Part Number	Description	Quantity
CM5Z-9916A315-A	High Voltage Lower Battery Connector Shield	1
CM5Z-8A424-A	Coolant Filter	1
Obtain Locally	Daubert Nox-Rust® 7703-W	As Needed

Warranty Status: Eligible under provisions of New Vehicle Limited Warranty (NVLW)/Service Part Warranty (SPW)/Special Service Part (SSP)/Extended Service Plan (ESP) coverage. Limits/policies/prior approvals are not altered by a TSB. NVLW/SPW/SSP/ESP coverage limits are determined by the identified causal part and verified using the OASIS part coverage tool. For repairs covered by the NVLW, completion of the procedure outlined in this TSB does not require obtaining Prior Approval or completion of a Cost Cap.

Labor Times

Description	Operation No.	Time
2012-2016 Focus Electric: Perform Coolant Leak Inspection Procedure, Fails - Replace Upper And Lower High Voltage Batteries (Do Not Use With Any Other Labor Outside This Article)	DR202004A	4.1 Hrs.
2012-2016 Focus Electric: Perform Coolant Leak Inspection Procedure, Pass - Remove Lower Battery, Inspect Connectors On Lower Battery, Pass All Tests, Perform Corrosion Protection Procedure (Do Not Use With Any Other Labor Outside This Article)	DR202004B	1.7 Hrs.
2012-2016 Focus Electric: Perform Coolant Leak Inspection Procedure Pass - Remove Lower Battery, Inspect Connector On Lower Battery, Fails Connector	DR202004C	4.2 Hrs.

Tests, Replace Upper And Lower High Voltage Batteries (Do Not Use With Any Other Labor Outside This Article)		
2012-2016 Focus Electric: Extra Time To Install High Voltage Lower Battery Connector Shield (Can Be Use With A, B, Or C)	DR202004D	0.2 Hrs.

Repair/Claim Coding

Causal Part:	9916A315
Condition Code:	X2

Service Procedure

For repairs covered by the New Vehicle Limited Warranty, completion of the procedure outlined in this TSB does not require obtaining Prior Approval or completion of a Cost Cap.

1. Inspect both the upper and lower high voltage battery for evidence of internal coolant leakage. Refer to the Internal Coolant Leak Inspection procedure later in this article. Is there evidence of internal coolant leakage in either of the two separate batteries?
 - (1). Yes - both the upper and lower high voltage batteries must be replaced. Refer to the Battery Replacement Order Process later in this article. Repair is complete.
 - (2). No - proceed to Step 2.
2. Use OASIS and review the warranty history. Has Field Service Action (FSA) 16B02 been completed?
 - (1). Yes - this article does not apply. Refer to WSM, Section 414-03A for further diagnostics.
 - (2). No - proceed to Step 3.
3. Remove the high voltage lower battery. Refer to WSM, Section 414-03A. Inspect the 3 connectors on the left side of the high voltage lower battery for cracking. Are cracks present on any of the 3 connector bodies? (Figures 1-2)
 - (1). Yes - replace the upper and lower high voltage batteries. Refer to the Battery Replacement Order Process later in this article.
 - (2). No - proceed to Step 4.

Figure 1

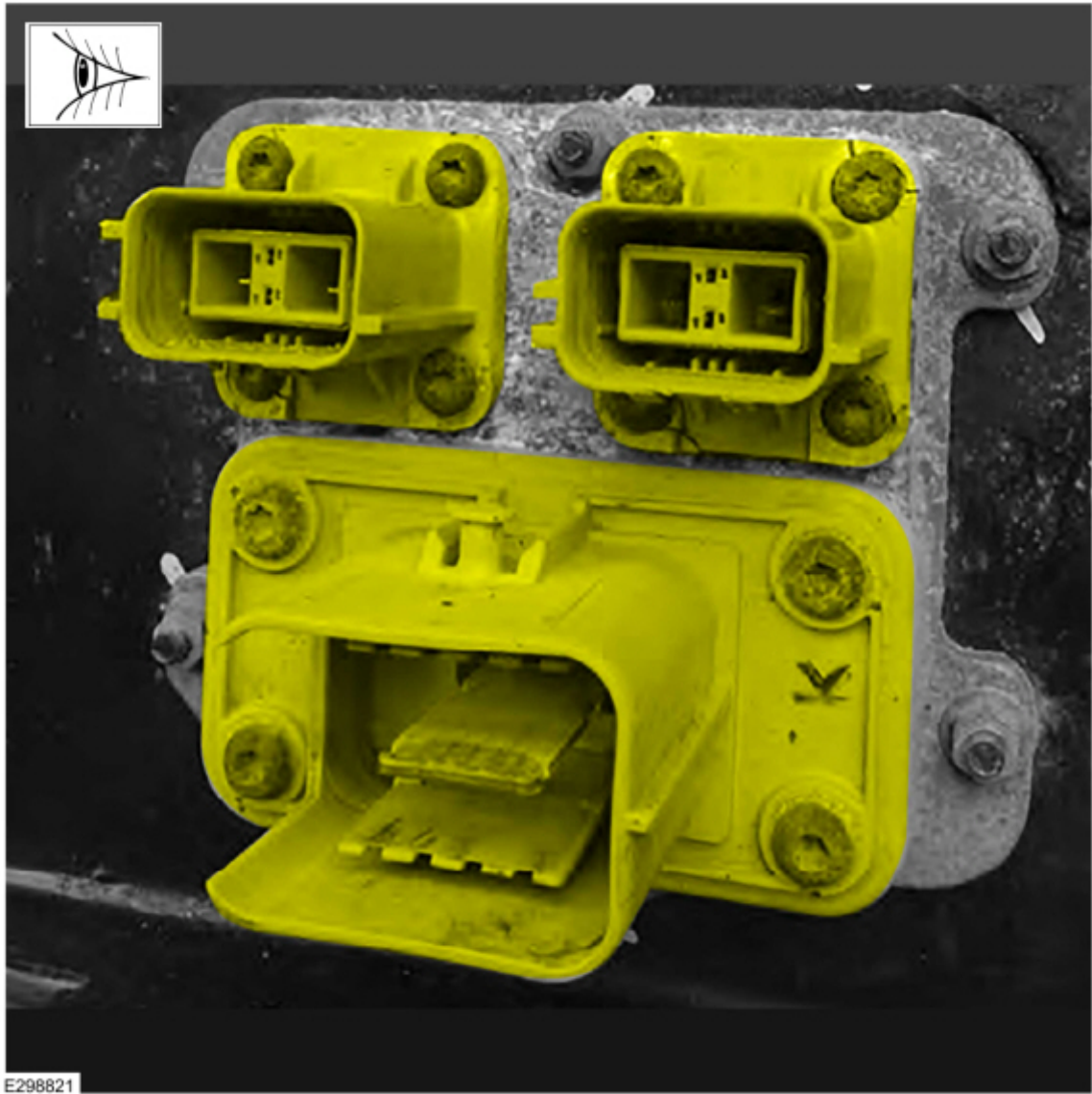

E298821

Figure 2

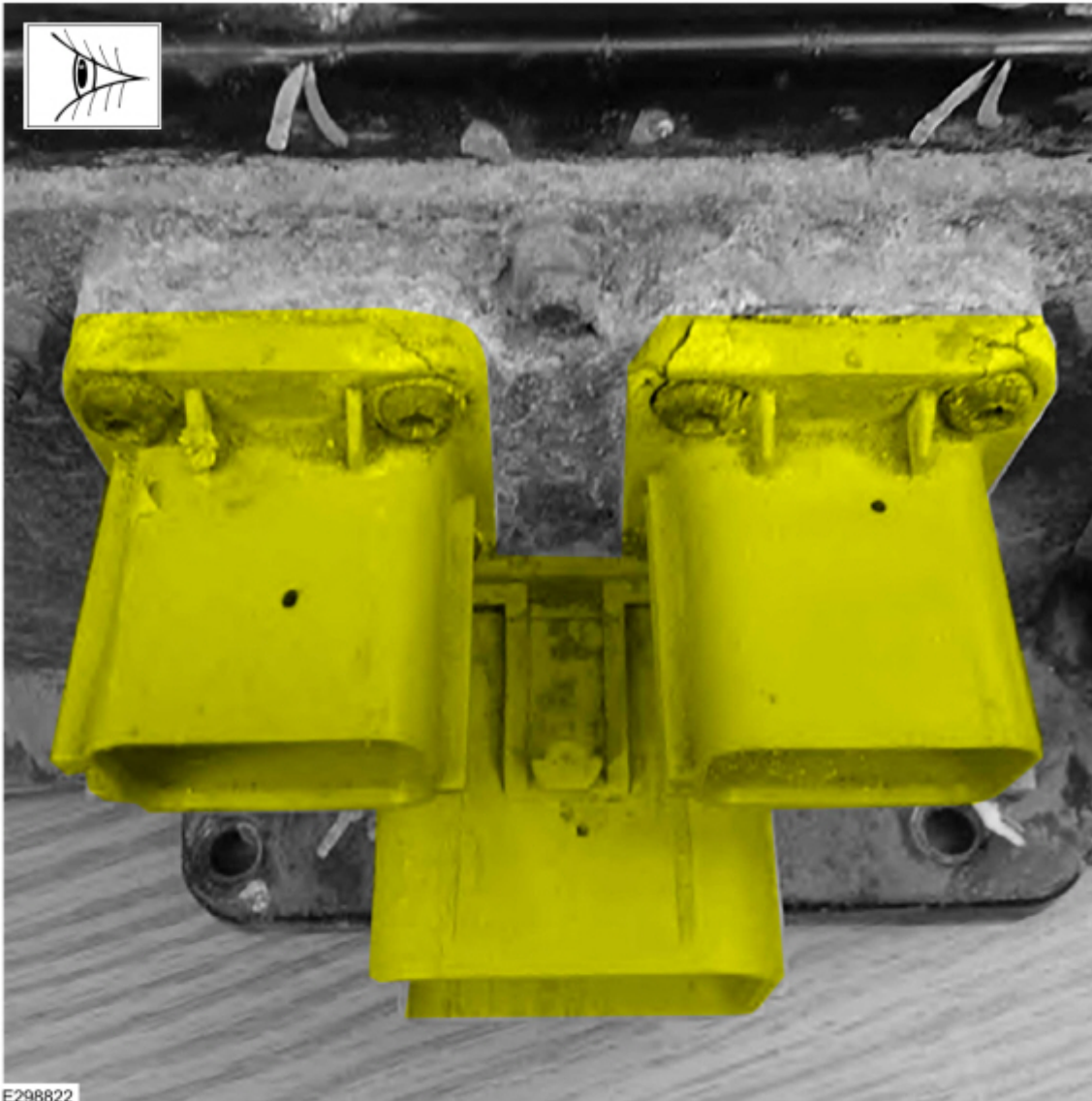

4. Apply chloroplast tape or equivalent to the connector faces to protect the terminals and keep the connector housing clean. (Figure 3)

Figure 3

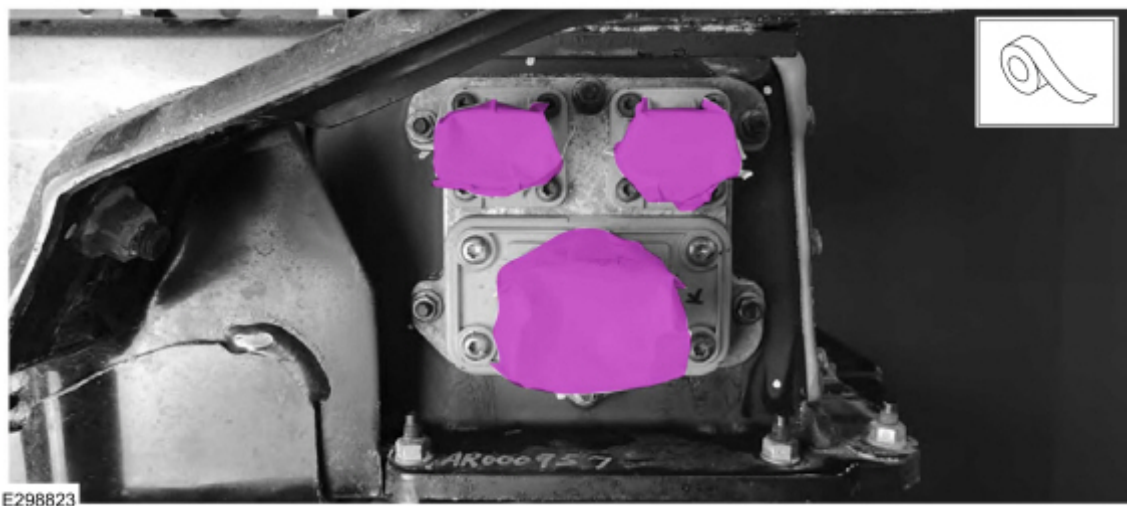

5. Using a brass wire brush, thoroughly clean the areas surrounding the 3 high voltage connectors to aluminum plate mating surfaces. Using compressed air, clean the loose debris from the connectors. (Figures 4-5)

Figure 4

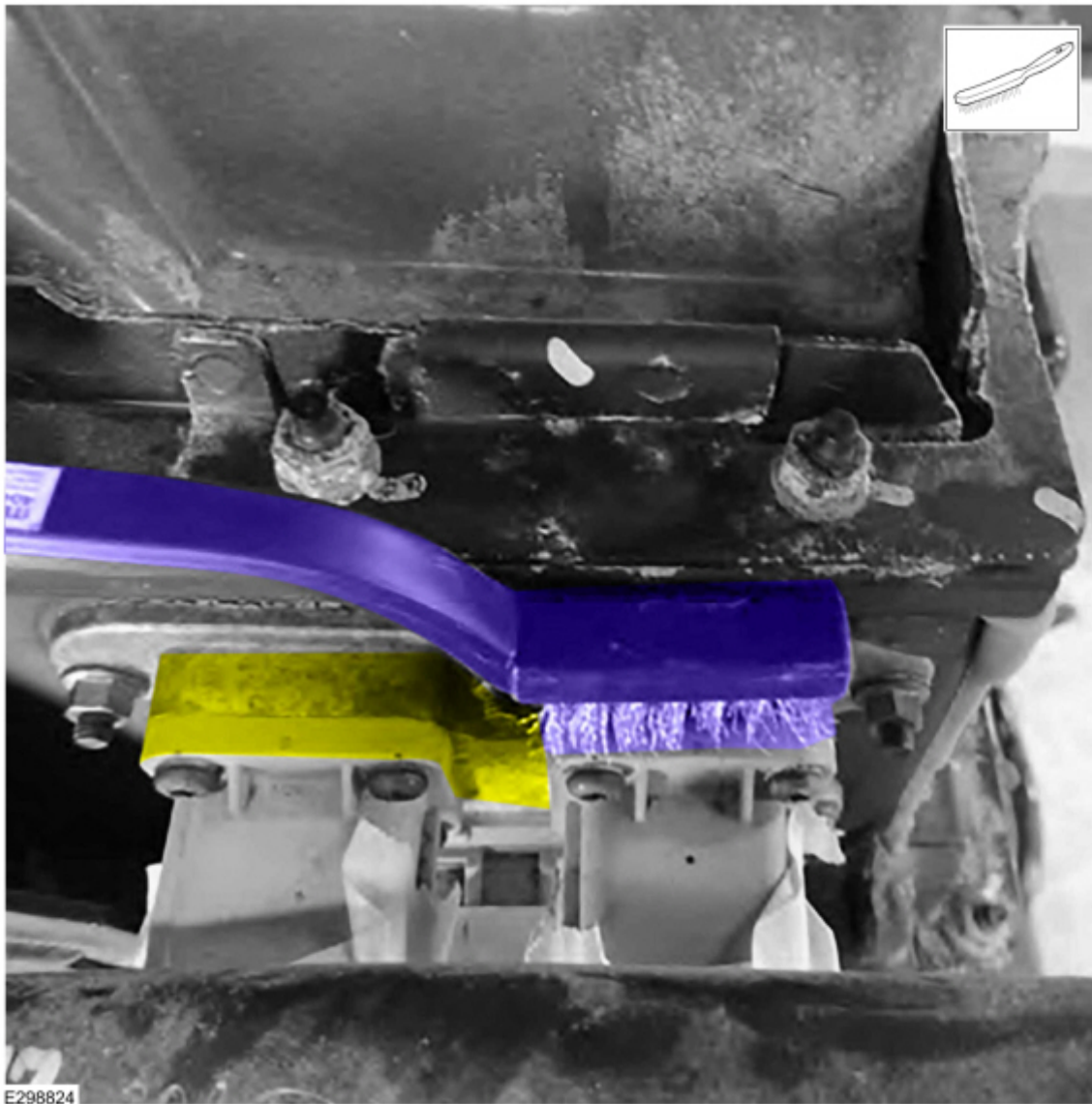
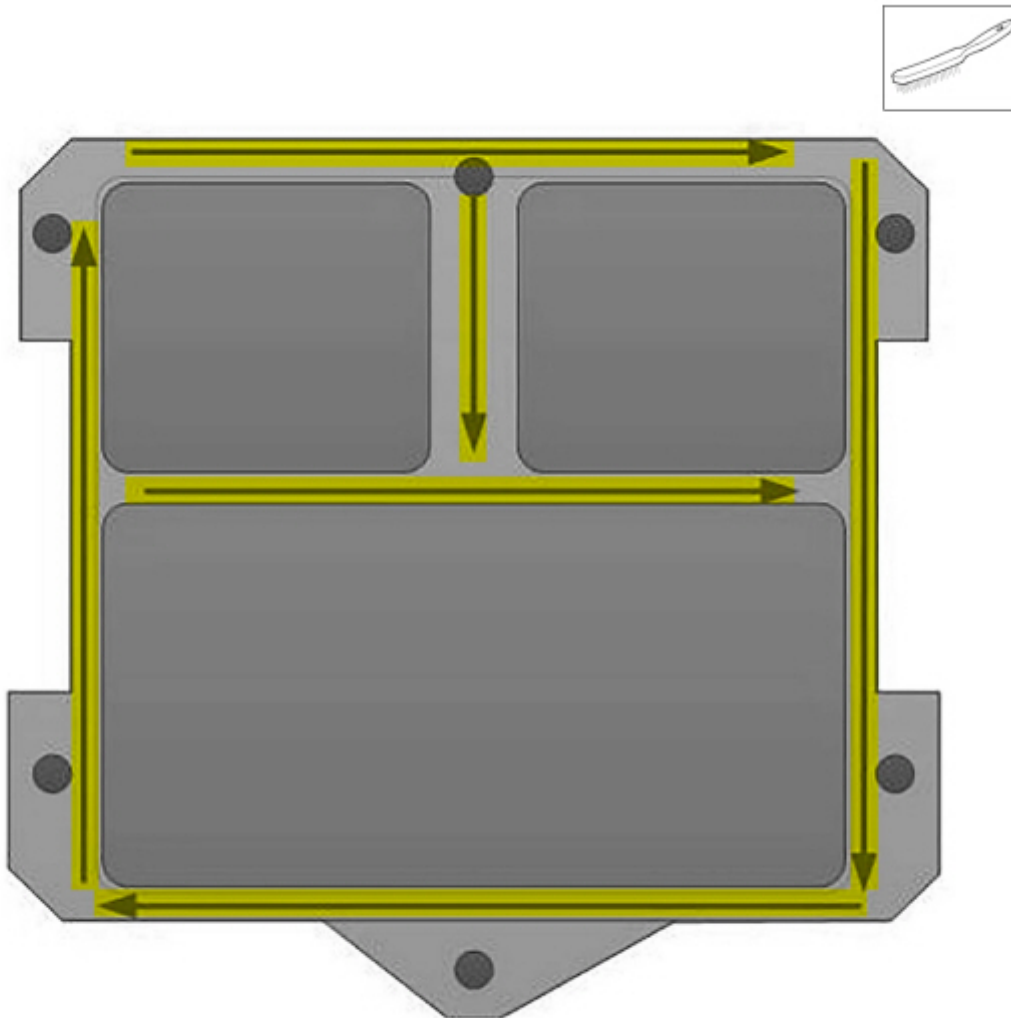

Figure 5



E298825

6. Insert a 0.076 mm (0.003 in.) feeler gauge between the aluminum plate and the top and sides of the two smaller high voltage connectors and the sides of the large high voltage connector. Does the feeler gauge fit between the aluminum plate and the connectors at one or more of the locations indicated in Figures 6-7?

- (1). Yes - replace the upper and lower high voltage batteries. Refer to the Battery Replacement Order Process later in this article.
- (2). No - proceed to Step 8.

Figure 6

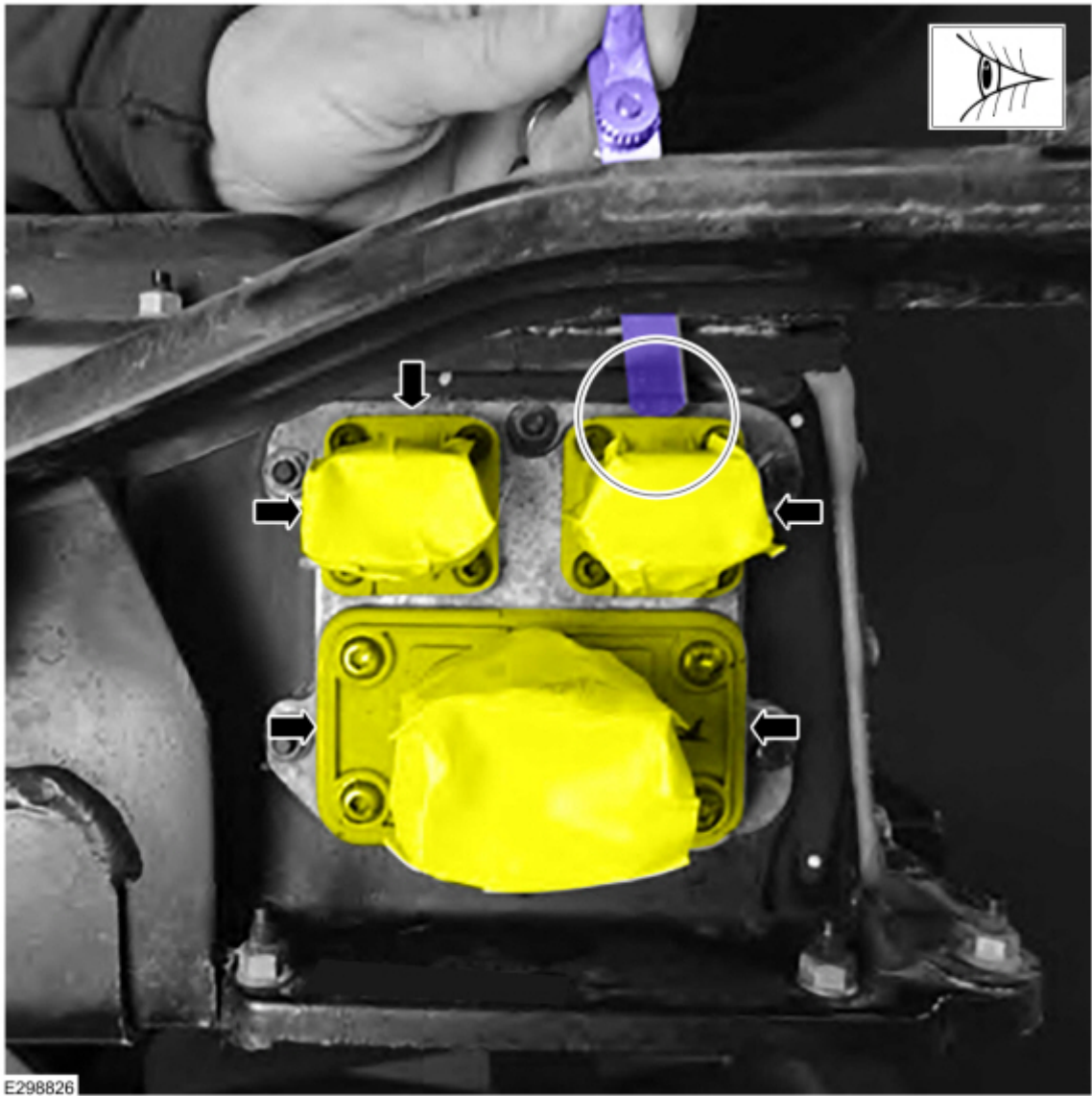

E298826

Figure 7

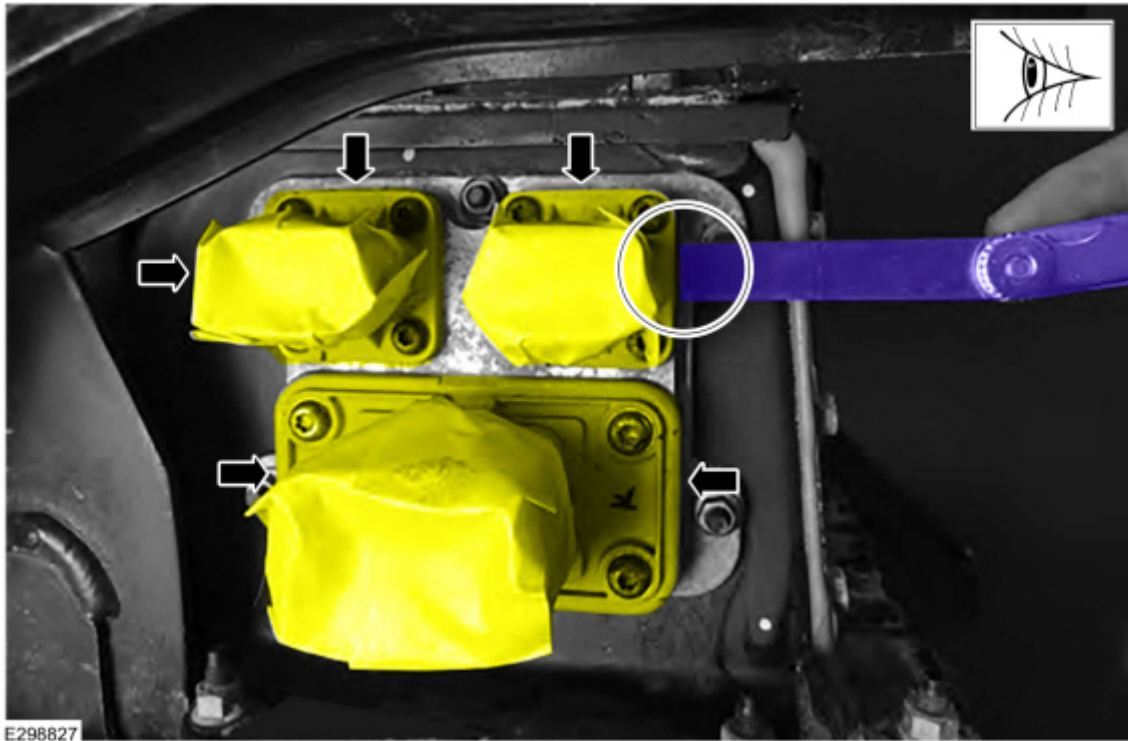

7. Insert a 0.380 mm (0.015 in.) feeler gauge between the aluminum plate and the top and bottom of the large high voltage connector. Does the feeler gauge fit between the aluminum plate and the large high voltage connector? (Figure 8)

(1). Yes - replace the upper and lower high voltage batteries. Refer to the Battery Replacement Order Process later in this article.

(2). No - proceed to the Apply Corrosion Protection procedure later in this article.

Figure 8

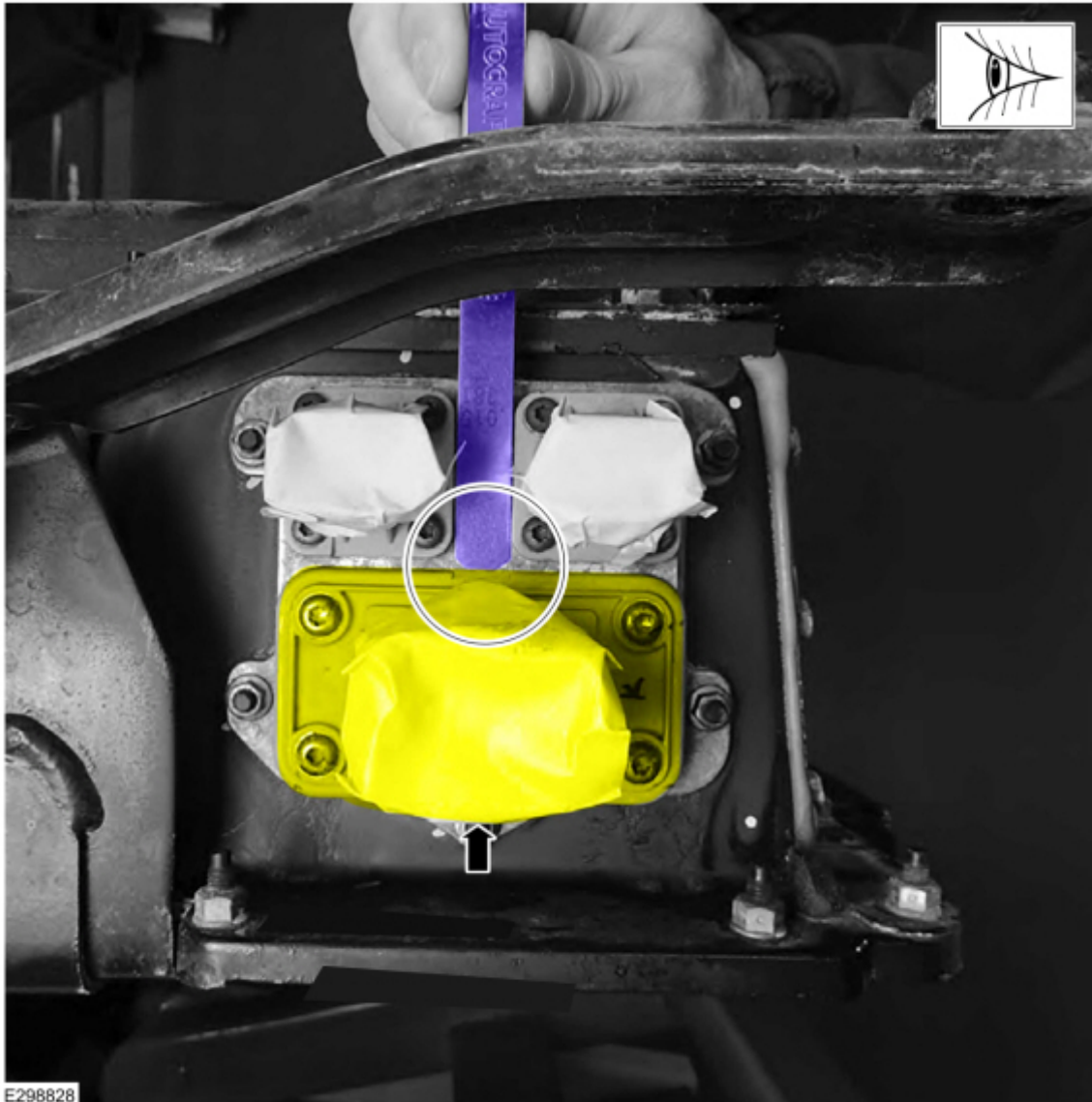

NOTE: The Battery Replacement Order process must only be completed if directed in Steps 1, 3, 6, or 7.

Internal Coolant Leak Inspection

1. Turn the ignition OFF. Check for low coolant levels in the coolant reservoir. This may be a sign of leaks in the coolant system including within the high voltage battery.
2. Depower the high voltage battery. Refer to WSM, Section 414-03A.
3. Remove the rubber grommet plugs from the bottom of the upper high voltage battery (Figure 9). Inspect the upper high voltage battery and rubber grommet plugs for evidence of internal coolant leakage. The plugs and battery case should be dry.

Figure 9

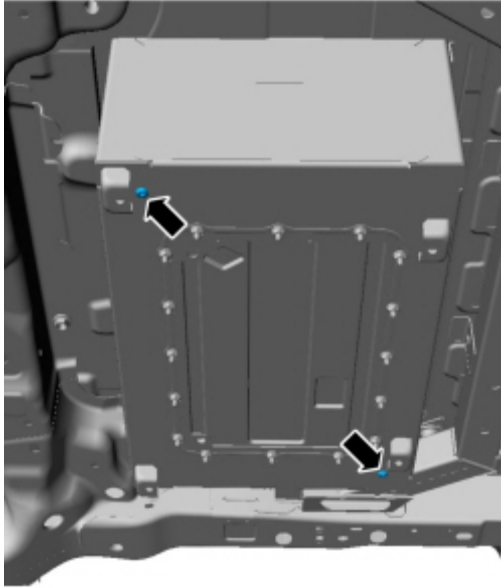

E146668

4. Remove the rubber grommet plug from the bottom of the lower high voltage battery (Figure 10). Inspect the lower high voltage battery and rubber grommet plugs for evidence of internal coolant leakage. The plugs and battery case should be dry.

Figure 10

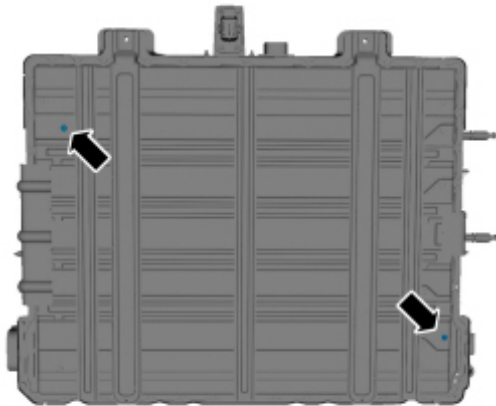

E146665

NOTE: Inspect both the upper and lower high voltage batteries for coolant leaks. These are two separate, sealed units in the vehicle each with two rubber grommet plugs which should be checked for coolant leak. If necessary, raise one side of the vehicle to allow the coolant to flow to one side of the battery to improve the chances of detecting a coolant leak.

Battery Replacement Order Process (If Internal Coolant Leak Or Connector Damage Is Present)

1. Locate and record the battery serial number on either the upper or lower high voltage battery. (Figures 11)

Figure 11



2. Connect the appropriate Ford diagnostic scan tool. Proceed to Toolbox > Powertrain > Service Functions > BECM Cell Capacity. Take a screenshot of this data.
3. Order a replacement battery. For USA dealerships, refer to Dealer Communication 07506. For Canadian dealerships, refer to SVB-2019-30N.
4. Install the replacement upper and lower high voltage batteries into the vehicle. Refer to WSM, Section 414-03A.
 - (1). Install the high voltage lower battery connector shield. Refer to the High Voltage Lower Battery Connector Shield Installation procedure in this article.
 - (2). Repair is complete.

Apply Corrosion Protection

1. Make sure the coroplast tape is completely covering the connector faces. (Figure 12)

Figure 12



2. Spray Daubert NOX-RUST® 7703-W generously around the perimeter of all 3 connectors to the aluminum plate mating surfaces. (Figure 12)
3. Allow the corrosion protection to penetrate for a minimum of 10 minutes.
4. Apply a second coat of corrosion protection.
5. Install the lower high voltage battery into the vehicle. Refer to WSM, Section 414-03A.
6. Proceed to the High Voltage Lower Battery Connector Shield Installation procedure later in this article.

High Voltage Lower Battery Connector Shield Installation

1. Remove the left rear wheel. Refer to WSM, Section 204-04A.
2. Remove the left rear fender well splash shield spring clip washer. (Figure 13)

Figure 13



3. Remove the bolt thread rubber cap. (Figure 14)

Figure 14



4. Remove the high voltage battery shield bolt and push pin. (Figure 15)

Figure 15

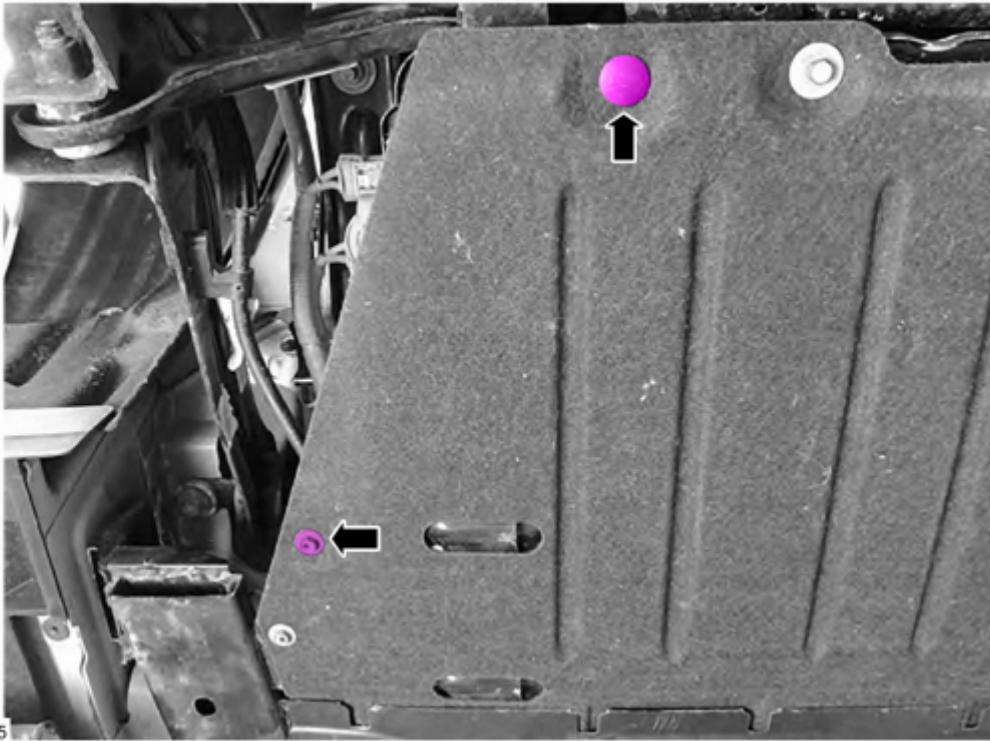

5. Position the top of the high voltage battery connector shield behind the left rear brake hose and trailing arm. (Figure 16)

Figure 16

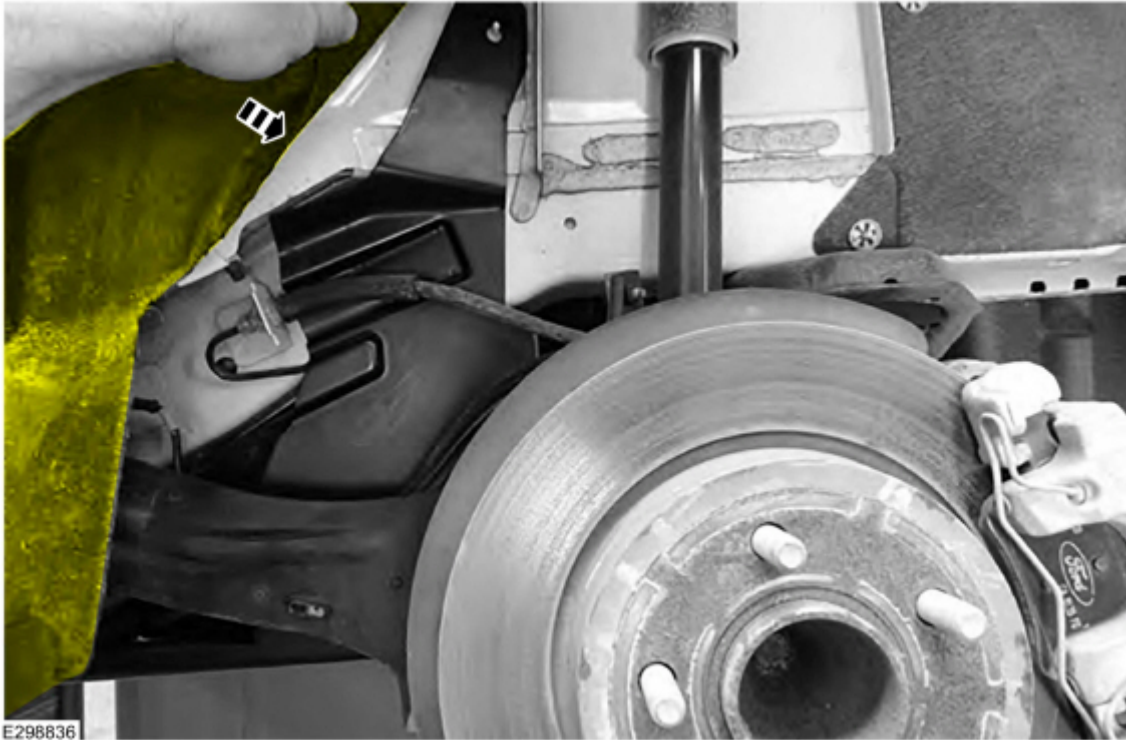

6. Install the left rear fender well splash shield spring clip washer. (Figure 13)

7. Install the high voltage battery shield bolt and push pin. (Figures 17-18)

Figure 17



Figure 18

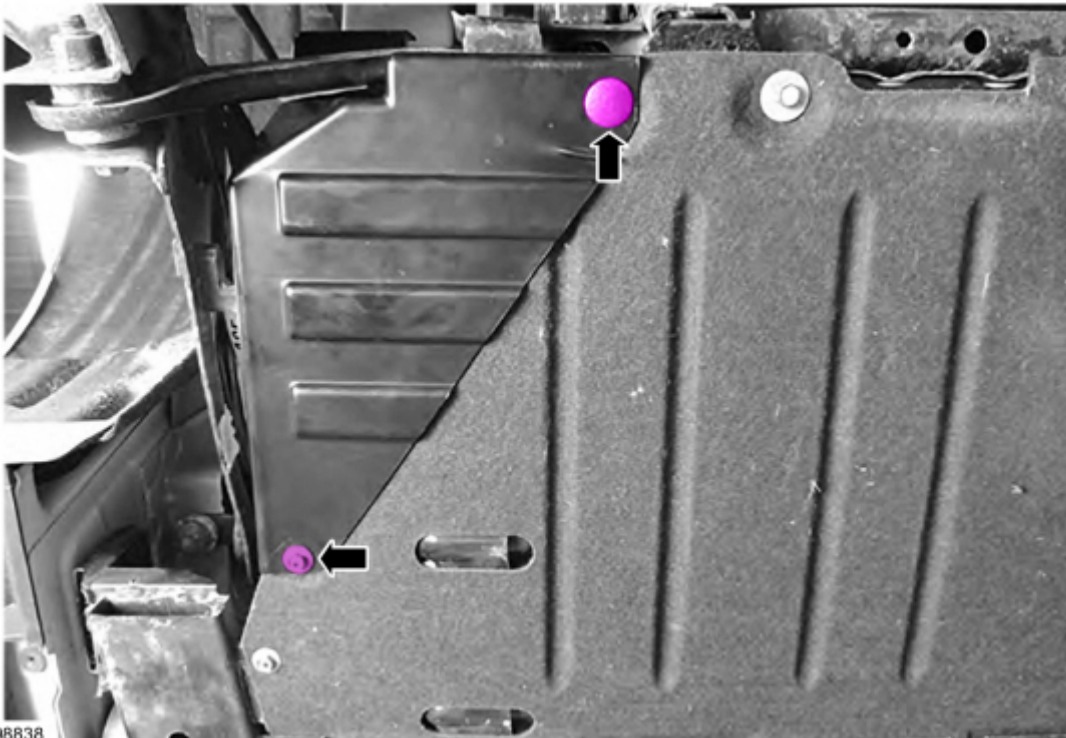

8. Tighten the high voltage battery shield bolt to 27 Nm (20 lb.ft)

9. Install the bolt thread rubber cap. (Figure 14)

10. Install the left rear wheel. Refer to WSM, Section 204-04A.

NOTE: The bolt thread rubber cap must be reinstalled. Failure to install the cap may result in parking brake cable damage.

© 2020 Ford Motor Company

All rights reserved.

NOTE: The information in Technical Service Bulletins is intended for use by trained, professional technicians with the knowledge, tools, and equipment to do the job properly and safely. It informs these technicians of conditions that may occur on some vehicles, or provides information that could assist in proper vehicle service. The procedures should not be performed by "do-it-yourselfers". Do not assume that a condition described affects your car or truck. Contact a Ford or Lincoln dealership to determine whether the Bulletin applies to your vehicle. Warranty Policy and Extended Service Plan documentation determine Warranty and/or Extended Service Plan coverage unless stated otherwise in the TSB article. The information in this Technical Service Bulletin (TSB) was current at the time of printing. Ford Motor Company reserves the right to supersede this information with updates. The most recent information is available through Ford Motor Company's on-line technical resources.