



# SURGE ACTUATORS

HYDRAULIC SURGE BRAKE ACTUATION

## INSTALLATION INSTRUCTIONS

### Model 80LP/85LP Actuator for 8000/8500 lbs Capacity Trailer Brakes

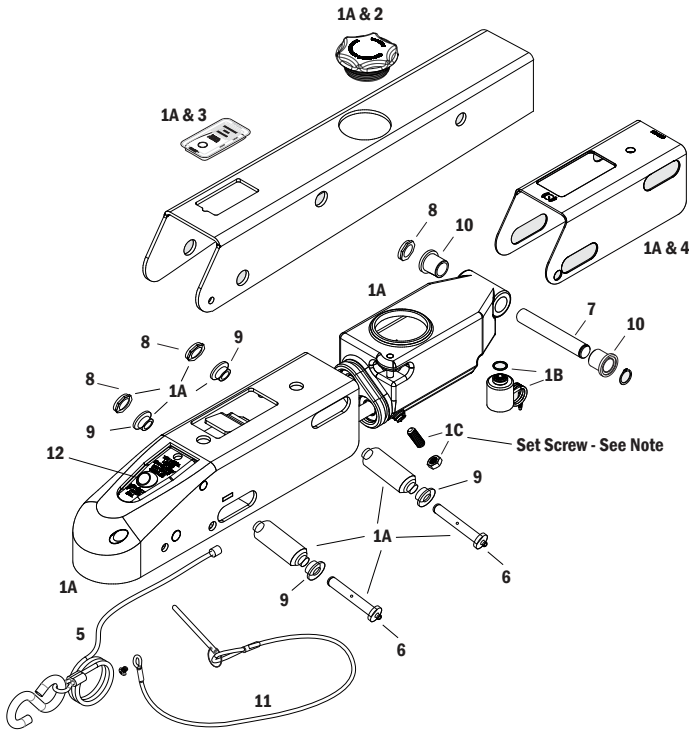

**IMPORTANT: READ AND UNDERSTAND THE ENTIRE INSTRUCTION PROCEDURE BEFORE USING YOUR BRAKES AND ACTUATOR.**

The Model 80LP/85LP works by the “surge” or “push” of the trailer toward the tow vehicle when braking. This automatically synchronizes the trailer brakes with the tow vehicle axle brakes. When the trailer pushes against the tow vehicle, the actuator telescopes together and applies force to the master cylinder, supplying hydraulic pressure to the brakes. The built in dampening shock absorber retards the telescoping shock against the hitch ball.

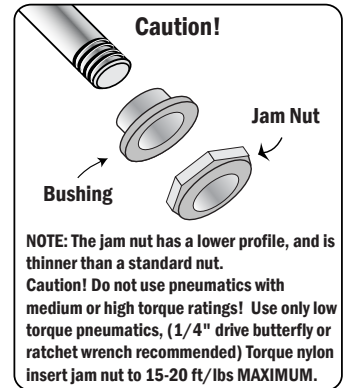

**⚠ CAUTION**

**Brake laws sometimes are minimum standards and you may wish to add additional brakes to your trailer. Read your tow vehicle's owner manual on towing capacity and other towing recommendations before installing brakes or this actuator.**

**Set Screw Note:**

The Set Screw provided in the bottom of the actuator housing should be adjusted to contact the flat provided on the master cylinder casting then backed off 1/4 turn and locked in that adjusted position by tightening the jam nut provided.

#	TDE Part #	DX Part #	Description
1A	17044K	K68-528-00	Disc Brake - Master Cylinder Repair Kit, Includes: all nuts, cuffs, pins and clips
NS	11286	054-240-00	Disc Brake Solenoid - used with disc brake actuators
NS	10880K	007-636-00	Set Screw with lock nut
2	48986A	068-572-00	Master Cylinder Cap with internal bladder
3	48984	068-570-00	Cover - E-Stop
4	48988	068-558-00	Slide Cuff
5	70685	074-498-00	E-Stop Cable
6	11135	019-085-00	Pin Bullet .56 x 4.3" with zerc fitting
7	48989-3	068-692-00	Pin Bullet .62" x 4.3" without zerc fitting
8	10544	006-705-00	Jam Nut for 11135 & 48989-3
9	48753B	014-306-00	Bushing Short
10	48989-4	014-307-00	Bushing Long
11	50301	074-477-00	Safety Cable with stainless steel pin
12	48971	K74-564-00	Latch Kit

This Actuator is completely assembled and ready to install.

- Hydraulic brake lines should be installed on the trailer as described in the installation manual supplied with the brakes. **Note: Some disc brakes require the use of flexible brake lines at the connection point on the brake caliper. Follow brake manufacturer instructions.**
- Use a pressure type brake bleeder to bleed brakes, following manufacturer's instructions or manually bleed the brakes using instructions on page 3.
- Check with your state motor vehicle department for laws concerning minimum trailer brake requirements. Some states may require brakes on all axles.
- Road test trailer a short distance to activate the actuator several times.

**RATED CAPACITY:**

Maximum Actuator Capacity:  
 80LP-8000 lbs. Gross Load, 800 lbs. Maximum Tongue Load  
 85LP-8500 lbs. Gross Load, 850 lbs. Maximum Tongue Load

The actual in-service rating is limited to that of the ball and hitch being used or the trailer manufacturer's GVWR shown on the certification label, whichever is lower (Note: GVWR is the Gross Vehicle Weight Rating which includes the trailer and the load weight as a Total Gross Weight).

## CAUTION

**AVOID sharp turns, which can cause the actuator to bind or jackknife against the tow vehicle or cause a bend in the tongue. Either can damage the actuator causing brake failure. AVOID towing trailer across large bumps or dips that may over stress the connection between the trailer and tow vehicle, as this could result in damage to the actuator.**

### HITCHING TRAILER

1. The vehicle, towing hitch and ball must have a rating equal to or greater than trailer GVWR.
2. Model 80LP/85LP will accept 2" trailer hitch balls rated for 8,000/8,500 lbs or more only. Trailer balls larger than 2.00" or out of round will not fit the coupler or may result in coupler failure. Balls smaller than 1.97" can cause shock loading and sudden disconnection. Make certain ball latch is in correct position to retain the hitch ball. Push latch back until safety latch engages plate below latch. Insert safety pin into forward hole as a safety lock for the hitch ball coupler prior to towing. Do not tow trailer if coupler is damaged.
3. Connect safety cables or chains using crossed pattern under tongue, or follow trailer manufacturer's directions. NOTE: The E-stop cable must have slack to make turns right and left without activating the brakes.
4. Connect actuator breakaway cable S-hook to the tow vehicle only. Do not connect S-hook to the safety cables or chains.
5. The breakaway system is designed to only operate after the trailer detaches from the tow vehicle and the safety chains have failed. The breakaway is not a parking brake. Do not use as such.

## CAUTION

- **The breakaway system is not designed to operate if the trailer does not separate completely from the tow vehicle, or if the tongue goes under the rear of the tow vehicle.**
- **In the event that the breakaway system is used, check all system components (cable, S-hooks, etc.) for proper working order. Replace any damaged parts with genuine Dexter parts only.**
- **When resetting the breakaway system, keep hands and fingers clear as you reset the mechanism. Hydraulic pressure held in the system may cause the assembly to snap back suddenly.**

6. If the E-stop is accidentally applied while unhitching, see the last page for E-stop release instructions.
7. Any control devices that restrict operation of the actuator cannot be used. This includes certain sway control devices. The actuator must be free to telescope in response to braking action of the tow vehicle.

## CAUTION

**A loose fit between the coupler and hitch ball can cause the actuator and hitch ball to separate, causing serious damage, injury or death. Check coupler every time prior to towing and at each stop on long trips. Always make certain that coupler latch safety pin is securely installed into coupler latch.**

## CAUTION

- **A minimum of 5% tongue weight and a maximum 10% tongue weight of the trailer GVWR must be located on the hitch ball. The Trailer tongue should be parallel to the ground. Too much weight can cause premature brake actuation and loss of control of the towing vehicle. Too little tongue weight can cause the trailer to fishtail, resulting in loss of control of the tow vehicle and trailer (total trailer weight GVWR includes weight of the trailer plus load).**
- **Never allow the coupler latch safety pin to remain in the reverse lockout position hole. After reverse maneuvering, always insert coupler latch safety pin back into coupler latch. FAILURE TO REMOVE SAFETY PIN FROM REVERSE LOCK OUT POSITION HOLE WILL PREVENT FORWARD MOVEMENT BREAKING THAT CAN RESULT IN SERIOUS PROPERTY DAMAGE, INJURY OR DEATH.**

8. Equalizing or weight distributing hitches may be used, allow six to eight inches free chain length.

## CAUTION

**Tongue weight beyond rating limits will interfere with performance of actuator, braking system and the tow vehicle.**

9. The actuator is designed for use with Free-Backing trailer brakes. To block braking action, (in order to back up) with other types of brakes, use an electric solenoid. The actuator is designed for use with Free-Backing trailer brakes. To block braking action, (in order to back up) with other types of brakes including disc brakes, use an electric solenoid. Place the safety pin in the hole on the side of the actuator housing to block movement of the actuator for reverse movement without brakes. DANGER: Failure to remove pin will also prevent forward braking. Pin must be in the lower, forward hole as a safety lock for the hitch ball coupler latch when towing at all times.

## CAUTION

**Failure to install the hitch pin before towing can result in accidental opening of the coupler hitch latch, which can lead to the trailer coming off of the hitch ball, causing serious damage, injury or death. If pin will not fit into the front lower hole, the coupler is not attached properly. Reset coupler on hitch ball.**

### VEHICLE WIRING - with Free Backing Brake Solenoid

1. Disconnect trailer hitch and any wiring connectors from the vehicle.
2. Connect a 14 gauge wire to the backup (reverse) light wire of the vehicle. This wire should be of sufficient length to attach to the existing vehicle/trailer wire receptacle. The end of this wire will require a female end that will match the solenoid male connector wire.
3. For ease of use, tape or band the end of the reverse light wire to the vehicle's trailer electrical connector.

**MAINTENANCE**

**⚠ CAUTION**

The exterior of the actuator and brakes should always be rinsed with fresh water after use in corrosive conditions. Before storing trailer, clean brakes and repack the bearings. Failure to properly maintain the actuator could cause serious damage, injury or death.

1. Always check the brake fluid reservoir before using trailer. Make sure it is at least half full. If not, refill to 3/8" below the top of the reservoir with DOT 3 brake fluid. Check for leaks and repair as required. Never reuse brake fluid.

**⚠ CAUTION**

**DO NOT REUSE BRAKE FLUID.** Always use fresh DOT 3 fluid from a fresh container. Failure to maintain proper levels of fluid in the reservoir will cause brake failure.

2. To extend coupler and ball life, coat both with a thin coating of grease. This will also eliminate squeaking. Wipe clean and renew film each time trailer is used.
3. Examine the actuator for bent parts or wear each time the trailer is used. Replace parts as necessary.
4. There are no user adjustments on the actuator.
5. Actuator travel (shown by coupler roller path) over 1" indicates needing to adjust the brakes, adding fluid to the reservoir, needing to bleed the brakes or check connections for leaks. Adjust per instructions found in brake installation manual. In general, back-off adjusters on drum brakes from locked position, as required. Adjust Free-Backing brakes by rotating in forward direction only. Failure to adjust may result in loss of braking. Disc brakes do not require adjustment, check for pad wear.
6. While towing, if the actuator appears to be knocking against the hitch ball while starting or stopping, check brake fluid reservoir and fill if below 3/8" full from the top. Low level could indicate a leak in the brake system.

**Bleeding Model 80LP/85LP Actuator**

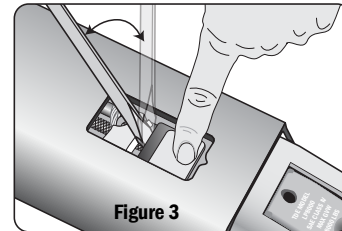
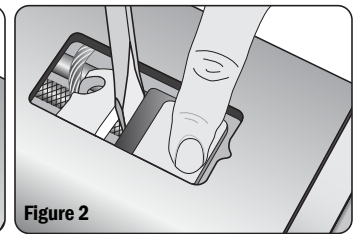
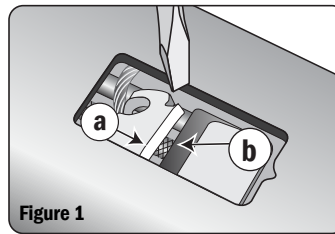

1. Fill the master cylinder with DOT 3 brake Fluid.
2. To pump bleed the master cylinder, remove the access cover. Insert a flat tip screwdriver between the brake release lever (Fig.1-a) and the emergency stop release bracket (Fig.1-b). Hold down the emergency stop release bracket (Fig. 2). Pump the brake fluid by pushing/pulling the screwdriver forward and back to bleed the brakes manually (Fig. 3).
3. To pressurize the master cylinder brake lines & brakes; follow brake bleeding instructions for brakes to complete the bleeding process.

**Emergency Brake Is Engaged:**

Figures 4 and 5 show the top of the actuator/access cover.

1. Figure 4 shows NORMAL POSITION. Be sure that there are no signs of the red EMERGENCY STOP bracket in view.
2. Figure 5 shows the EMERGENCY STOP release bracket (red) is visible, the emergency brake has been engaged.
3. To Release the Emergency Brake: Press down the emergency stop release bracket with a screwdriver (Fig. 3-a) until the E-stop bracket snaps back into the NORMAL POSITION (Fig. 1).

**⚠ CAUTION**

**DO NOT TOW THE VEHICLE IF YOU SEE "RED" .**

**Figure 1: Emergency Stop Disengaged**

**Figure 2: Emergency Stop Engaged. DO NOT TOW**

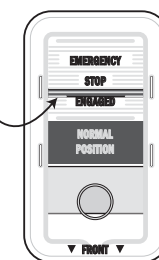
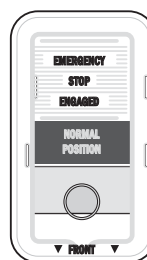

Emergency Stop Bracket (in Red)

**Figure 3**

