



BRAKERITE[®]

ELECTRIC/HYDRAULIC ACTUATION



OPERATION MAINTENANCE SERVICE MANUAL

BRAKERITE ELECTRIC HYDRAULIC BRAKE ACTUATION SYSTEM

Introduction2

 Safety Information.....2

 Overview2

Electrical3

Installation4

Operation6

 Service and Maintenance.....6

 Troubleshooting.....6

Introduction

Thank you for purchasing a Dexter BrakeRite Actuator system. Dexter has been a pioneer in development of brake actuation and brakes. Dexter's BrakeRite systems are state of the art ELECTRIC over HYDRAULIC BRAKE (EHB) systems.

CAUTION

- **Verify wire connections are correct before energizing or powering BrakeRite system. Improper wiring can damage actuation system causing system failure.**
- **Failure to use proper gauge wire can result in improper operation or failure of components and braking ability. For runs of wire more than twenty (20) feet, larger gauge wire should be used.**
- **Proper grounding must be observed. Grounding to trailer frame is not acceptable. See provided diagrams for proper wiring.**

Dexter's BrakeRite systems use electric power from towing vehicle to drive hydraulic power source. In breakaway situations, electric power is supplied by a battery if trailer is completely separated from tow vehicle. This battery is charged by built in control circuitry in Dexter's BrakeRite. All BrakeRite systems are actuated one of three ways; by brake pedal of tow vehicle being depressed, manual over-ride switch on in-cab brake controller, or during breakaway situation when breakaway switch is activated. Both manual override and breakaway systems are required by Federal Law.

All Dexter BrakeRite systems require in-cab electric brake controller which is not provided in these systems. These actuators will operate from most electric brake controllers WHEN PROPERLY INSTALLED.

Proper electrical wiring is critical for performance of any BrakeRite system. Improper wiring can damage actuation system causing system failure. A pure ground and direct power (+12 VCD) with fuse or circuit breaker (30 amp) are necessary for proper performance. Adequate wire size, 12 Gauge Stranded Automotive or heavier, is required as long runs increase line loss. Line loss and poor grounding will result in poor performance or total loss of braking. Connection for BrakeRite II SD and BrakeRite Plug and Play systems are provided by pre-wired harnesses and plug connectors are keyed so they cannot be connected wrong, however, if plug between tow vehicle and trailer is not wired properly, unit will not function properly, or at all. See proper wiring diagram for assistance.

Safety Information

- Installation, maintenance, or repair should ONLY be performed by qualified persons who have training or knowledge of the systems.

- When installing, maintaining, or repairing Dexter equipment, wear eye protection and other necessary personal protective equipment.
- Dexter equipment must be maintained in safe working order at all times. Trailer equipment should be inspected before, during, and after use for wear and damage.
- Inspect trailer and equipment before each use.
- Check that brake fluid level is within 3/8" from filter opening.
- Verify breakaway protection is working properly.
- Confirm breakaway battery is charged properly.
- Confirm brake actuator being used can supply enough hydraulic pressure and volume to actuate disc brakes. As a common rule, disc brakes require more pressure and larger volume of fluid than drum brakes of same size.
- Use DOT3, DOT4 or DOT 5 brake fluid. Failure to use correct brake fluid may result in brake failure.

CAUTION

DOT5 fluid can be used with new systems only. This includes brake lines and brakes. Flush BrakeRite with mineral oil before filling with DOT5 fluid. Once DOT5 brake fluid is used, only use DOT5 fluid and do not use DOT3 or DOT 4 fluids. Do not use DOT5 fluid on a used BrakeRite.

- Be familiar with state laws in operation of towed vehicles, especially with regard to brake and braking requirements. Towing a trailer may require additional braking time and distance. Allow for this in driving habits while towing.
- Make certain equipped trailer is safely supported at all times during installation, maintenance or repair.
- After every hookup, test and confirm trailer brake system is operating correctly and adequately before transportation on roads

Before each towing, perform these steps:

1. Check brake fluid reservoir is within 3/8" from filler opening of fresh, clean DOT3, DOT4 or DOT 5 brake fluid.
2. Check for leaks. Service as required.
3. Examine actuator for wear, or other damage. Have affected components serviced. Verify actuator mounting bolts are tight.
4. Test actuator and brake function before transport. Failure to properly adjust brakes will result in loss of braking.

There are no adjustments on BrakeRite actuators. BrakeRites are shipped with tamper proof seals between cover and casting. Warranty is void if seals are broken. Dexter genuine replacement parts are available at dexteraxle.com

Overview

All BrakeRite units are similar, differences are with electronics. BrakeRite EHB has an ECB (electronic control board) built within unit and has five wires exiting. Termination of these five wires is performed by installer per wiring diagram. If not properly connected, unit will not perform properly or at all. BrakeRite II has no ECB and has a 3 wire cable with Female Weather Pack plug; therefore it requires a control module. With

BrakeRite II SD (Severe Duty) control modules are used.

All BrakeRite models use the same electric motor driven piston pump and electronic controlled pressure relief valve. Exterior appearance between them is very similar, only wires exiting housing, control board, and distinct Model Markings are different.

SD Control Kit for BrakeRite II is same control circuitry as BrakeRite EHB. However efforts to improve installation efficiencies and reliability SD Control kit consists of; one SD control module, one I/O harness with 7-pin RV plug 7-pin RV receptacle with three wiretap with Weather Pack plug, and one battery cable with Weather Pack plug. All electrical circuitry are individual circuits are keyed so wires cannot be connected improperly. Great importance must be placed upon proper wiring in tow vehicle plug.

Brake pressure for all BrakeRite models are controlled by most in-cab electronic brake controllers. Brake performance is selected by driver. Manual override can also be applied if driver wishes to apply only trailer brakes.

Federal law requires ALL trailers with brakes have ability to apply brakes in event trailer become uncoupled from tow vehicle. This requires a breakaway switch and power source (battery) on trailer. All BrakeRite systems have circuitry for breakaway, however, breakaway switches are provided only with SD control kits and no breakaway batteries are supplied with any kits.

Electrical

All BrakeRite models are 12 Volt DC with negative ground. Improper connections and grounding may result in system damage. For both BrakeRite EHB & BrakeRite II SD, 12 gauge or larger wire must be run from tow vehicle battery to BrakeRite with a fuse or circuit breaker for protection.

Control leads for BrakeRite EHB & BrakeRite II SD require 16 gauge or larger wires be used. If undersized wiring is used for power leads, low voltages may occur with slow response times and poor performance of brake system.

All BrakeRite models must use a BREAKAWAY BATTERY OF AT LEAST 9 AMP HOURS. For RV applications, the house battery may be used as the breakaway battery as long as the above conditions are met at all times. Breakaway battery serves to operate all BrakeRite models as a peaking battery for applications and to supply power in a breakaway condition. BrakeRite II supplies power for both breakaway conditions and also supplies power to operate the brake system. All three systems have internal chargers to maintain charge on battery from tow vehicle.

Breakaway switch (circuit) is required by law. For standard BrakeRite EHB kits, neither switch nor batteries are included. For standard BrakeRite II kits, breakaway switch is included while batteries are not. Breakaway cables and batteries can be ordered separately if needed. When properly installed, breakaway switch applies trailer brakes in event trailer becomes un-coupled from tow vehicle. Closing of a circuit is required to activate breakaway function. Breakaway switch is normally close switch held OPEN by a plastic key. A cable is attached to key and to tow vehicle. If units become uncoupled, cable pulls key from switch closing circuit activating breakaway function and applying trailer brakes.

ECB (electronic control board) has a battery protection circuit to assure breakaway (auxiliary) battery maintains a charge at all times and prevents a surge charge which could damage battery. Protection is also designed into board to prevent power draw from auxiliary battery to tow vehicles electrical system.

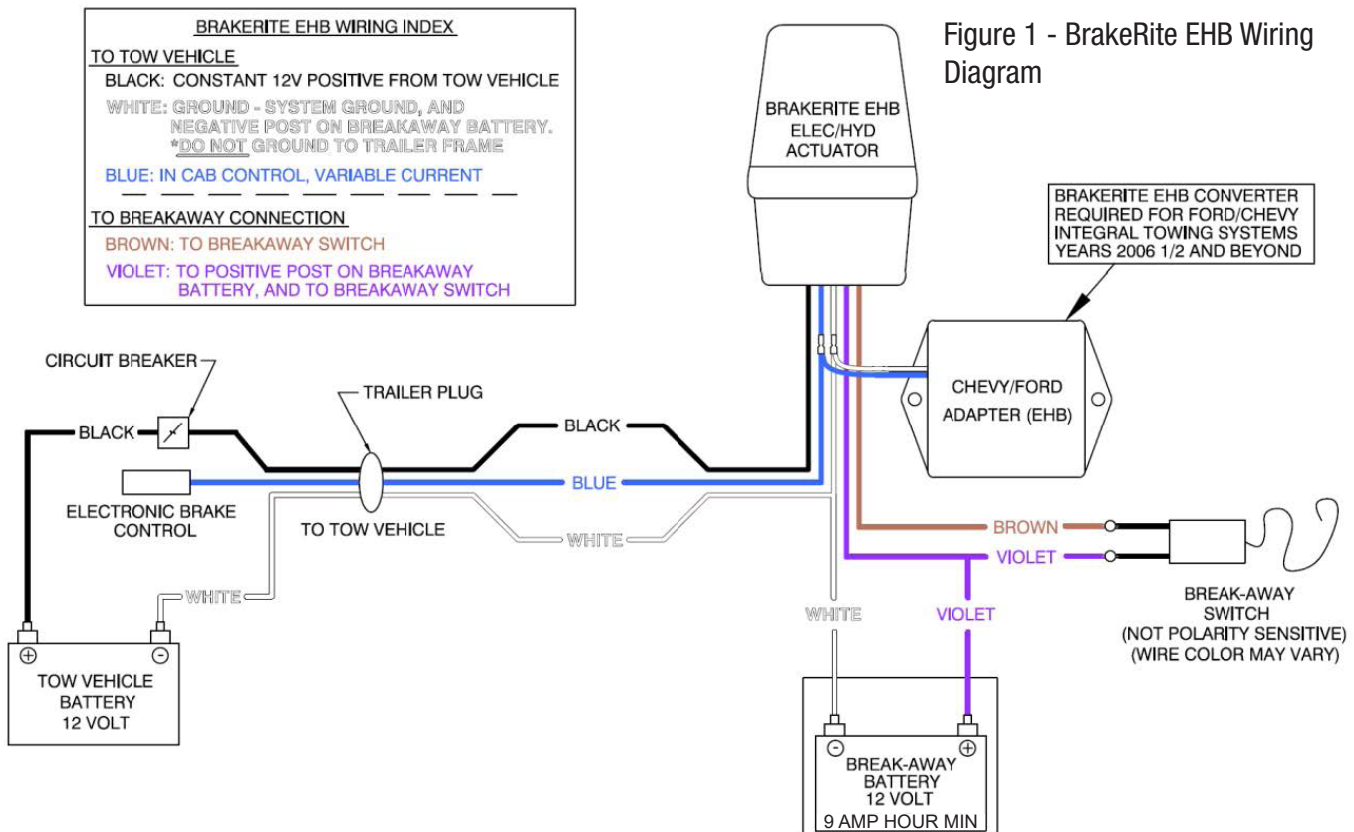
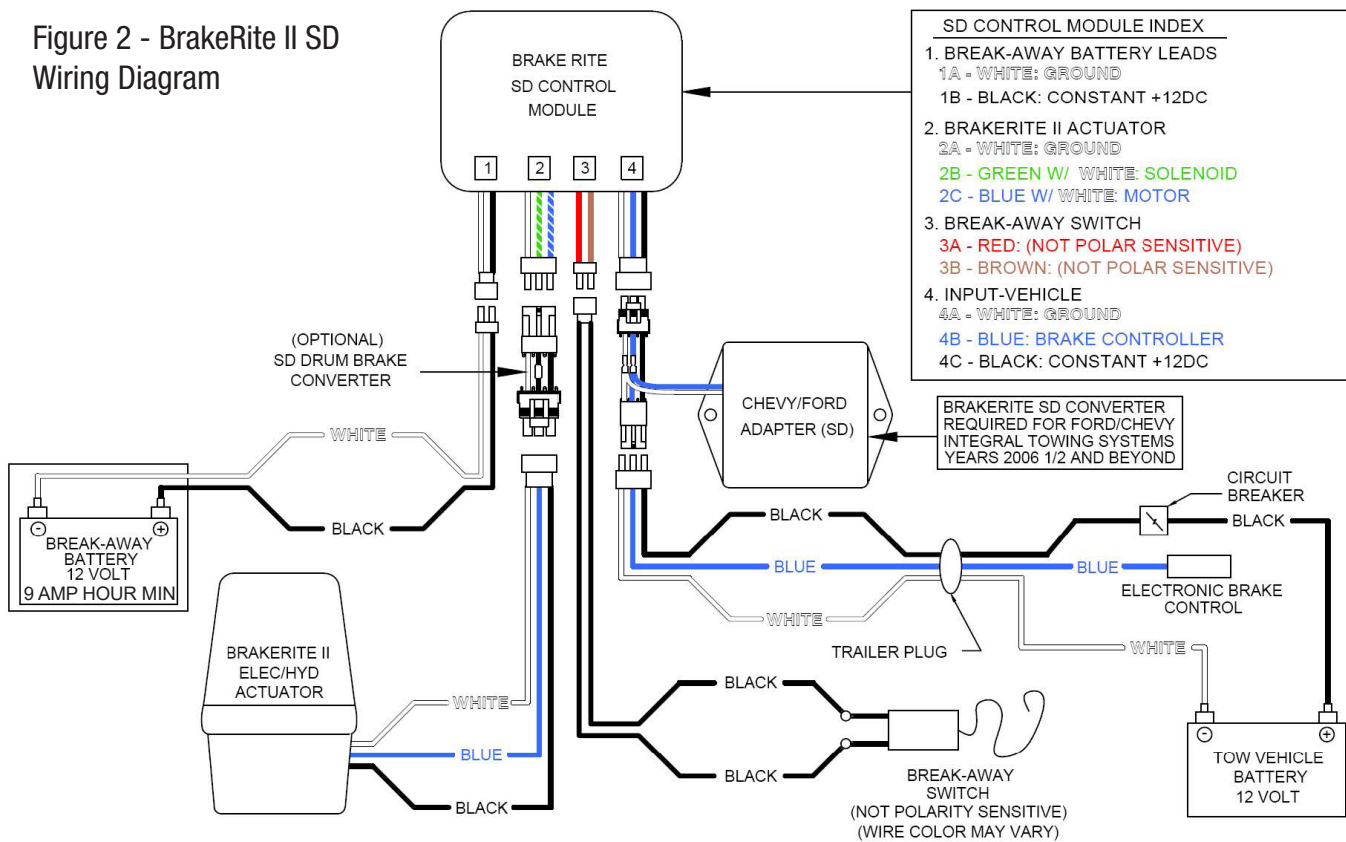

Figure 2 - BrakeRite II SD Wiring Diagram



Installation

Mounting location of any BrakeRite model is at discretion of installer, however accessibility for service, protection from damage, and ability to minimize length while protecting brake lines are factors to be considered. Approximate physical envelope for power unit is 6" front to back, 7-1/4 left to right, and 9-1/8 high. Two sets of mounting holes are provided in power unit; one set of four located on bottom (1/4 - 20 UNC x 5/8 deep) and one set of three located on back (5/16 - 18 UNC x 5/8 deep). The last page of this manual has a 1:1 scale drawing of power unit mounting holes. Drawing can be used as a marking and drilling diagram for custom bracketry and mounting hardware. Verify scale before use.

All BrakeRites have a 1/8 - 27 NPTF port located on lower front of housing and a straight 1/8 - 27 NPTF Male by #3 Female Inverted Tube seat (3/4 - 24 NPTF) adapter. When installing any adapter, DO NOT USE TEFLON PIPE TAPE as properly mated brass fitting joints DO NOT require a sealant. Route brake lines to axles per Brake Line Fitting Kit manufacturer's instructions. Use of flexible tubing/hose should be kept to a minimum. Using too much flexible tubing will cause brake delay. Secure all tubing for maximum protection from pinching, vibration, corrosion, or road hazards. When bending and flaring steel tubing, always use proper tools to assure sound connections and prevent kinked lines. Kinked and/or damaged brake lines can cause restriction in flow resulting in poor braking or no brakes at all.

Depending on brake system chosen, there are various approaches to be considered for electrical connections. Though Dexter produces BrakeRite systems, Dexter has NO control over how towing vehicle or trailer has been wired or its color coding. Therefore, when installing any BrakeRite system, it is important that all wiring is connected per

these instructions. While it is desirable to establish a ground between frame, BrakeRite unit, and negative side of breakaway battery, NEVER RELY SOLELY ON FRAME GROUNDING. Always use good ground leads between ALL specified points. If rewiring from electric brakes, start wiring as close to front of trailer as possible. A junction box, pin box, or 7-way plug, are preferred starting locations. As electrical portion of installation is carried out, make certain wires are properly routed, wrapped, anchored, and protected to prevent damage, catching on road hazards, or rubbing on frame components. When making connections in circuits, other than plug-in connectors, desirable joint is a solder joint. If using crimp-type joints, always use manufacturer's recommended crimping tools in accordance with manufacturer's directions and always properly wrap and protect all joints to prevent shorting and corrosion. Heat shrinking joints also help prevent water causing shorts or corrosion.

BrakeRite EHB requires installer assure all wire are connected properly. See wiring diagram Figure 1 for preferred method for electrical wiring. This method requires an independent battery solely for brake system. However, towed vehicle auxiliary batter can be used in place of breakaway battery if it is in good condition and fully charged. NOTE: If trailer has set for an extended period of time, auxiliary battery may have been discharged excessively resulting in poor or no braking. If system is being converted from electric brakes, remove as much old brake wiring as possible and run new wires. This will ensure wires used are of adequate size and give better operation of BrakeRite.

Function and size of five (5) wires exiting BrakeRite EBH are as follows:

- White: 12 gauge, 12 VDC negative (-) system ground
- Black: 12 gauge, 12 VDC positive (+) system power in

- Blue: 16 gauge, Brake Control Input (from in cab electronic brake controller)
- Brown: 16 gauge, Breakaway Input (from one lead of breakaway switch)
- Violet (Mauve): 14 gauge, 12 VDC Input/Output between Unit and Breakaway battery. (2nd lead of breakaway switch is also connected to 12 VDC positive of breakaway battery)

BrakeRite II SD and BrakeRite Plug and Play kits have a complete wiring harness as a plug-in system and all connections within have been preselected so that upon installation connections are simply plugged in. It is crucial that 7-pin RV receptacle on tow vehicle is wired per Figure 4.

Two basic options are whether to use an auxiliary battery on trailer, if one is available, or to install a separate breakaway battery (preferred). No battery is supplied with standard kits. Figure 2 illustrates preferred method (separate breakaway battery). Trailer auxiliary battery can be used in place of breakaway battery if it is in good condition, fully charged.

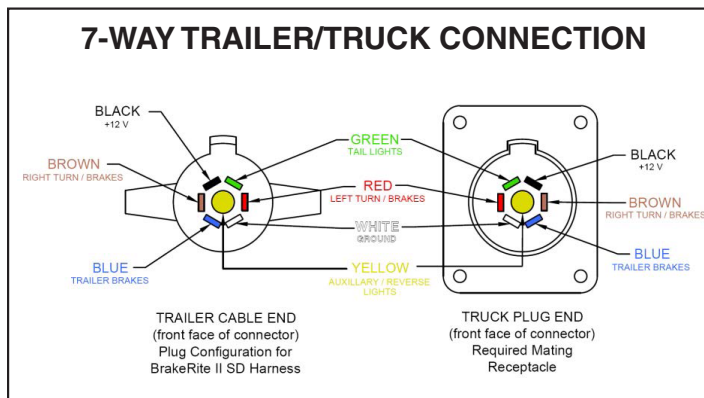

Figure 4 - Most Common Factory Installed Wiring Arrangement

4-Pin Flat Connector on tow vehicle must be wired as shown in Figure 5. Similar to SD kit, options that are left is whether to use an auxiliary battery on trailer, if one is available or to install a separate breakaway battery (preferred). No battery is supplied with standard kit. Figure 2 illustrates preferred method (separate breakaway battery) however; trailer auxiliary battery can be used in place of breakaway battery if it is in good condition, fully charged and meets amperage requirements.

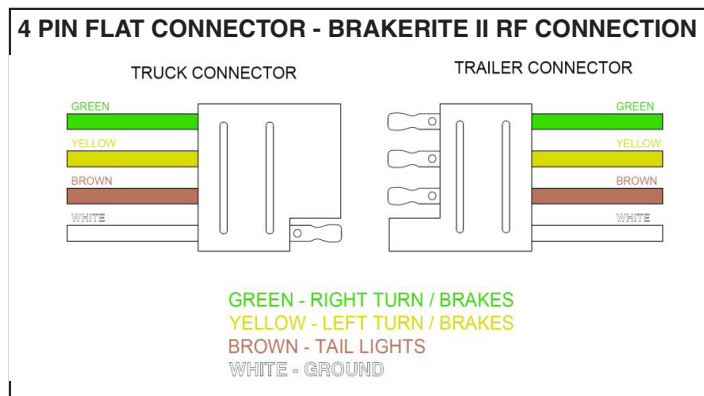

Figure 5 - Industry Standard Four Pin Configuration

After unit has been mounted, brake lines installed, and electrical connection completed, system start-up can begin. Remove one filler cap and fill reservoir to within 3/8 of filler cap opening. (Either cap can

be used as both fill same reservoir) Fill reservoir with NEW DOT3, DOT4 or DOT5 BRAKE FLUID. Never reuse brake fluid that has been salvaged or removed from another system. Contaminated brake fluid may cause damage resulting in system failure. Never mix grades of DOT fluid.

All air must be removed from brakes and brake lines prior to trailer operation. To bleed brakes, remove key from breakaway switch to start unit. Starting with brake furthest from actuator, open bleeder screw and allow it to remain open until brake fluid releases free of air bubbles. Close bleeder screw and move to next brake closer to BrakeRite until all brakes have been bled. While performing bleeding process, monitor fluid level in reservoir so air is not pumped into brake lines because of low fluid. Running BrakeRite pump dry can damage motor. To prevent spilling brake fluid on ground, place one end of length of plastic tubing over end of bleeder screw and other end should be placed into a container so that fluid flow can be monitored for bubbles.

⚠ CAUTION

- Use fresh DOT3 or DOT4 brake fluid from sealed container. **DO NOT** reuse brake fluid. Failure to use fresh brake fluid increases chance of brake failure.
- Use care when handling brake fluid. **DO NOT** allow brake fluid to contact painted surfaces. It will damage surface finishes. Wipe up spills immediately and wash area with water.
- This is a high pressure system. **ALL** air must be removed. Any air in brake lines will cause brakes not to function properly. **Bleed** brake system completely.

After all brakes have been bled, replace key in breakaway switch.

⚠ CAUTION

DOT5 fluid can be used with new systems only. This includes brake lines and brakes. Flush BrakeRite with mineral oil before filling with DOT5 fluid. Once DOT5 brake fluid is used, only use DOT5 fluid and do not use DOT3 or DOT 4 fluids. Do not use DOT5 fluid on a used BrakeRite.

Operation

When coupling trailer to tow vehicle always assure that two vehicles are coupled in accordance with vehicle manufacturer's instructions and that all coupling devices and procedures conform to applicable state and federal regulations. After units are properly coupled, connect electrical plug. Assure that safety cable from breakaway switch on trailer is connected to tow vehicle.

To assure proper connections have been made, most in-cab controllers have some type of indicator showing electrical connections are adequate. Consult in-cab controller manufacturer's operator manual for proper checking and setting procedures. Before moving vehicle depress tow vehicle brake pedal, BrakeRite unit should start (audibly hear unit). Release tow vehicle brake pedal and activate BrakeRite unit by operating manual override on in-cab controller. Again, unit will be heard running. With manual override, a tone change will occur as pressure builds relative to activation amount initiated from override switch. Do not attempt to move unit or trailer until brake system performs properly in described tests above.

After system responds to tests previously described, proceed with moving vehicle to establish feel for brake system and also to calibrate brake response based upon instructions given in brake controller manual. This adjustment should be performed in a parking lot or low traffic area. Do not attempt to operate unit in congested traffic or on major through fares until familiarized with feel and performance of brake system. Every operator and every vehicle have unique requirements and characteristics. Take time to be familiar with how unit feels, performance, and proper operation and setting selections of brake controller.

Trailer brakes are meant to assist tow vehicle in stopping of combined units and are not intended to stop entire combined unit. Two basic types of In-Cab Electronic Brake Controllers exist. Inertia based controllers create a small bias braking force when activated and modulates braking forces of trailer relative to braking reaction created by tow vehicle. Inertia controllers offer most desirable braking effect. Another type is time based controllers. Time based controllers turn on when tow vehicle's brake pedal is applied and braking for increases at a selected rate until it reaches a maximum set point. This does not produce as smooth of braking as inertia based controllers and is very speed sensitive. Time based brake controllers are NOT recommended for this reason.

Manual override is required by law and should be fully understood for proper and safe operation. This allows trailer brakes to be activated without depressing tow vehicles brake pedal.

Service and Maintenance

Periodic inspection of electrical connectors, wiring, brake lines, and hose for entire brake system to insure no abraded or bare wires, damaged steel lines, or damaged hoses exist. During inspection assure there are no loose or hanging objects that might drag or catch on during transport.

EVERY time trailer is coupled to tow vehicle, check following items:

- Check fluid level in reservoir. Fluid level must be maintained within 3/8 below filler opening. If brake fluid is required, add only new, clean DOT3, DOT4 or DOT5 brake fluid. Use caution when removing reservoir cap to prevent admission of any

contaminants into fluid reservoir.

- Check breakaway battery is charged and breakaway system works. Test by pulling cable on breakaway switch. If vehicle has been parked for long periods, breakaway battery may be discharged. If this situation occurs, charge battery per trailer manufacturer's recommendations prior to using trailer. If battery is discharged in cold environments, freezing battery, damage may have occurred to battery.
- Inspect coupler and safety chains to assure they are fully functional and for wear or damage. All equipment must meet manufacturer's specifications and all applicable laws.

All BrakeRite models are shipped from factory with tamper proof seals between cover and casting. Warranty is void if these seals have been broken. Genuine Dexter replacement parts are available at dexteraxle.com.

Troubleshooting

Experience has shown that virtually all problems with BrakeRite unit are results of INCORRECT or FAILED WIRING. If problems arise, consult applicable wiring diagram and inspect all wiring and terminations.

A bench test can be performed as follows. Connect Black wire to positive (+) and White to negative (-) power source. Proceed to momentarily tap Blue wire to positive (+) side of power source. Motor should switch on briefly. Next momentarily tap Brown wire to positive (+) side of power source. Motor should switch on briefly. If both tests work, problems are not in BrakeRite unit. Wiring and other components should be checked for problems.

ISSUE	SOLUTION
Indicator on In-Cab Controller shows no connection between tow vehicle and trailer	Inspect plug and wiring for open circuit. Consult applicable wiring diagram for proper connections.
Poor response time	Check and add brake fluid as required. Bleed brake lines and devices. Check input for adequate Charge (12VDC).
Inadequate or excessive trailer braking	Adjust gain control on In-Cab Controller
BrakeRite unit runs but does not build pressure	Assure proper brake fluid level, add fluid and bleed system as required
BrakeRite unit does not run when breakaway is pulled	Check breakaway battery charge and assure wires are properly connected
BrakeRite unit does not run when in-cab manual override is activated	Verify and connect wire connections in entire electrical circuit.

REAR MOUNTING HOLES

TOP ←
BOTTOM →

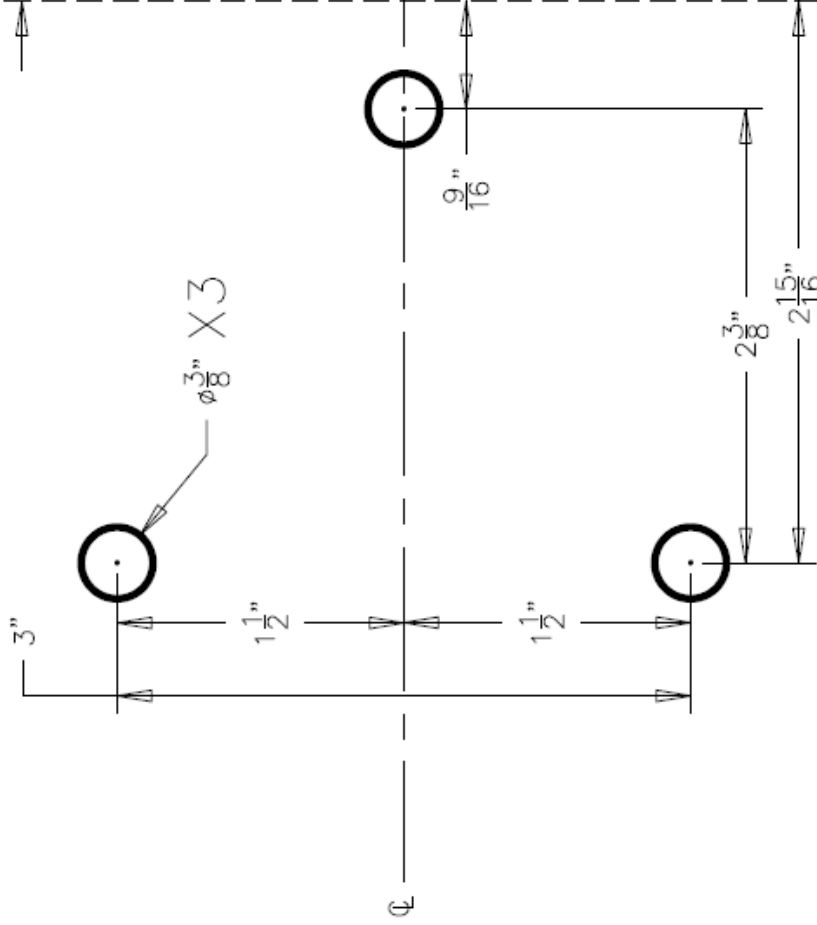

$\phi \frac{3}{8}$ " X 3

BOTTOM MOUNTING HOLES

BACK ←
FRONT →

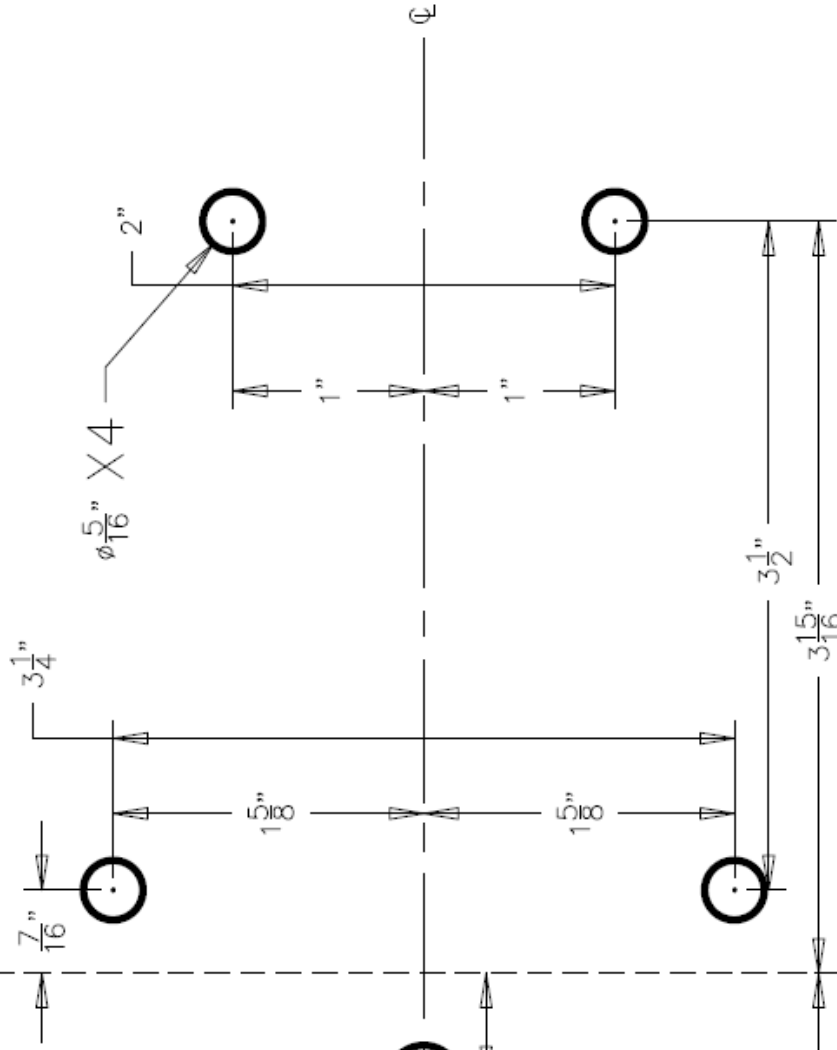

$\phi \frac{5}{16}$ " X 4

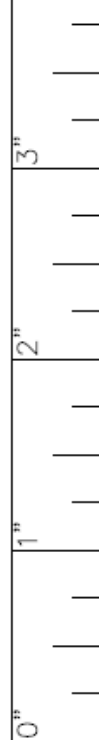

4" Use page for drilling template if needed.
Measure printed ruler for correct scale.
Page must be printed at 100% scale.
Fold along dashed line for mounting on both sides.

BRAKERITE MOUNTING
HOLE DIAGRAM



Together. Carrying what matters most.



www.dexteraxle.com

2900 Industrial Parkway East - Elkhart, IN 46516
Phone: 574-295-7888 - Fax: 574-295-8666

ISO 9001:2015 Certified

