

PREVOST

Instruction Sheet

IS-17900A

WHEEL FENDER STAINLESS STEEL PROTECTOR

H SERIES VEHICLES – B-1721- Today

REVISION:A This revision replaces all previous versions
2017-04-07 **Changed vehicle effectivity. Was 2004.**

MATERIAL

Kit #7770321 includes the following parts:

Part No.	Description	Qty
470933	FENDER PROTECTOR	8
506869	TAPE RUB ADH2 POL .031" x 1/4" x 300' / BLACK	1
684517	ADHESIVE SIMSON #ISR 70-03 / GREY / 310ml CARTRIDGE	1
504643	RIVET POP DOME OE 1/8x.640 SS	40
5001067	WASHER FL .128x.312x.032 SS	40
IS-17900	Instruction Sheet	1
FI-17900	Feuille d'instructions	1

NOTE

Material can be obtained through regular channels.

Other parts that may be required:

Part No.	Description	Qty
682986	STANDOX Anti-Silicone cleaning fluid, 4 liter	1

PROCEDURE



DANGER

Park vehicle safely, apply parking brake, stop engine. Prior to working on the vehicle, set the ignition switch to the OFF position and trip the main circuit breakers equipped with a trip button. On Commuter type vehicles, set the battery master switch (master cut-out) to the OFF position.

GLUING – BEST PRACTICES

Health & Safety

<p>DISCARD</p>  <p>WASTE PROPERLY</p>	<p>WEAR</p>  <p>GLOVES</p>	<p>WEAR</p>  <p>SAFETY GLASSES</p>
--------------------------------------------------------------------------------------------------------------------------------------	----------------------------------------------------------------------------------------------------------------------------	-------------------------------------------------------------------------------------------------------------------------------------

Work environment

- Free from excessive dust (ensure ventilation).
- Air jet prohibited. (Propels dust into the working environment and causes surface contamination from the oil of the pneumatic system).
- All products containing silicone are prohibited.

Temperature and % humidity: The standard is established at 23 °C (73°F) and 50% relative humidity.





Effect of temperature;

> 23 °C and/or > 50%, drying time and working time are reduced

< 23 °C and/or < 50%, drying time and working time are increased

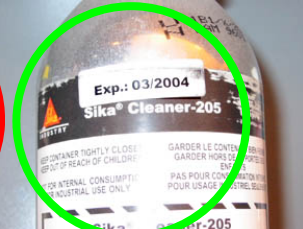
On the other hand, usage of products, parts, surface preparation and/or bonding is not allowed below 15°C.

General information for cleaning / surface preparation products

 <p>Do not rub back and forth</p>	 <p>Check the expiry date</p>	 <p>Do not pour directly from the bottle</p>	
			

NOTE

The kit includes the required material to install 8 stainless steel fender protectors on a vehicle.

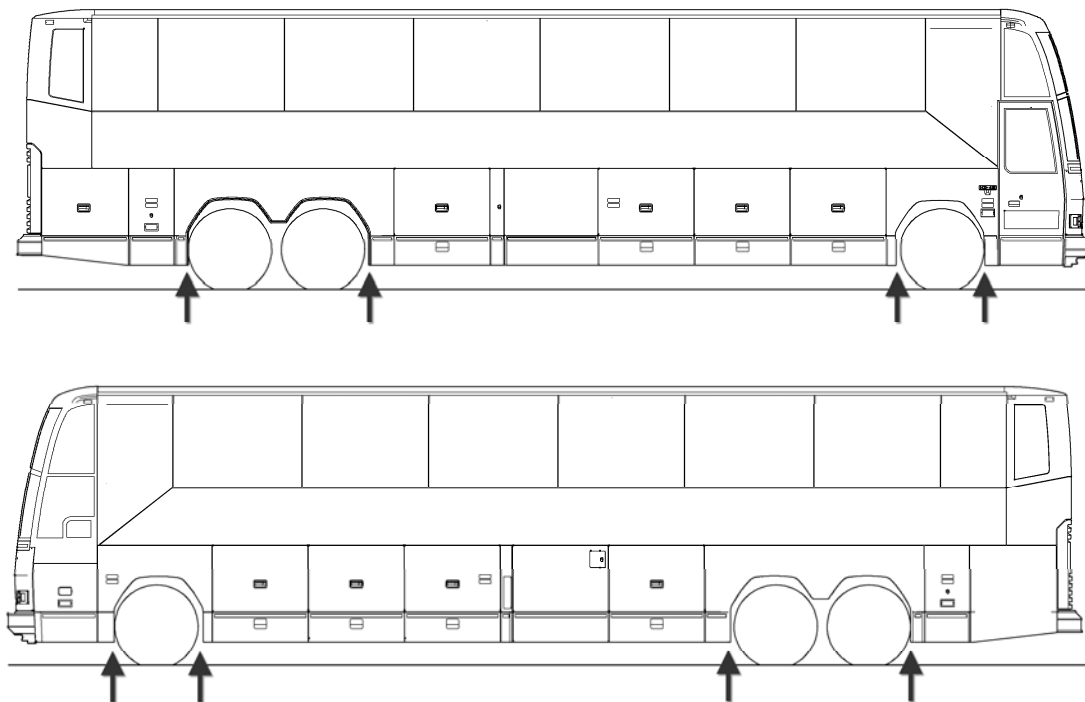

FIGURE 1 PROTECTOR LOCATIONS

1. Water-clean the fender's lower edge. Clean the inner and outer faces thoroughly, removing any dirt, salt, sand or road material. Dry the surface.
2. Next, clean the protector, removing any dust or residue.
3. Once dry, use anti-silicone to prepare the fender and protector surfaces for bonding.

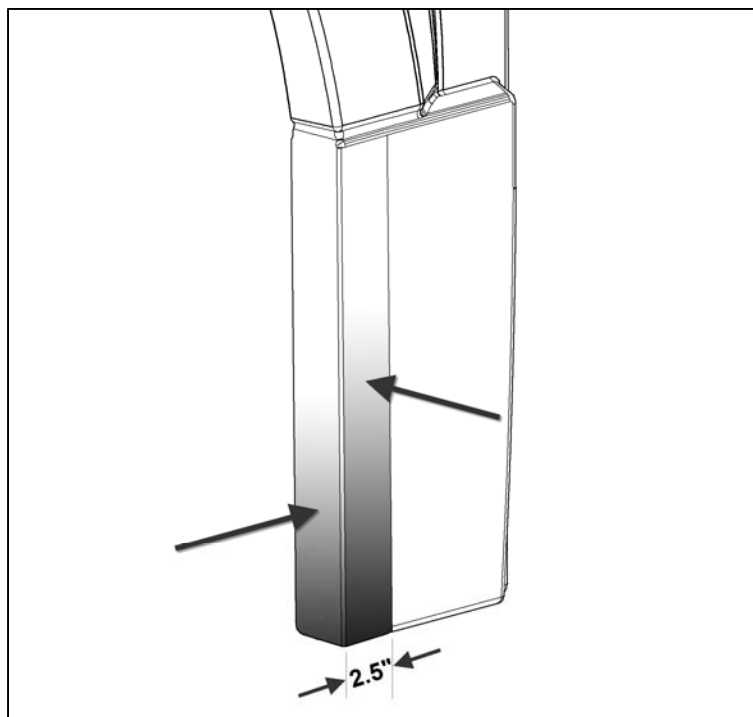

FIGURE 2 :CLEAN THESE AREAS ON FENDER

4. Select a glue applicator nozzle that creates 8mm high glue beads. (Figure 3)
5. If unavailable, cut an 8mm high triangular opening in the tip. (Figure 3)

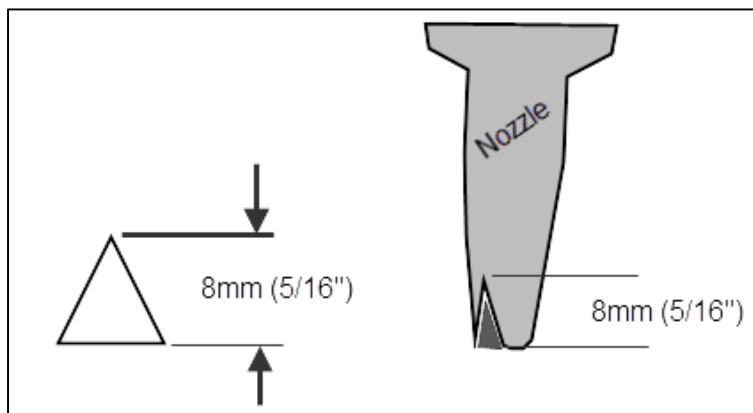

FIGURE 3 TRIANGULAR BEAD OF GLUE

6. Perform a dry fit of the protector on the fender. Mark tape positions with masking tape according to Figure 4.
7. Prepare two 14-1/4" lengths of double-face tape.
8. Immediately position the tapes on the fender.
9. Apply a bead of Simson glue between the tapes Figure 4.

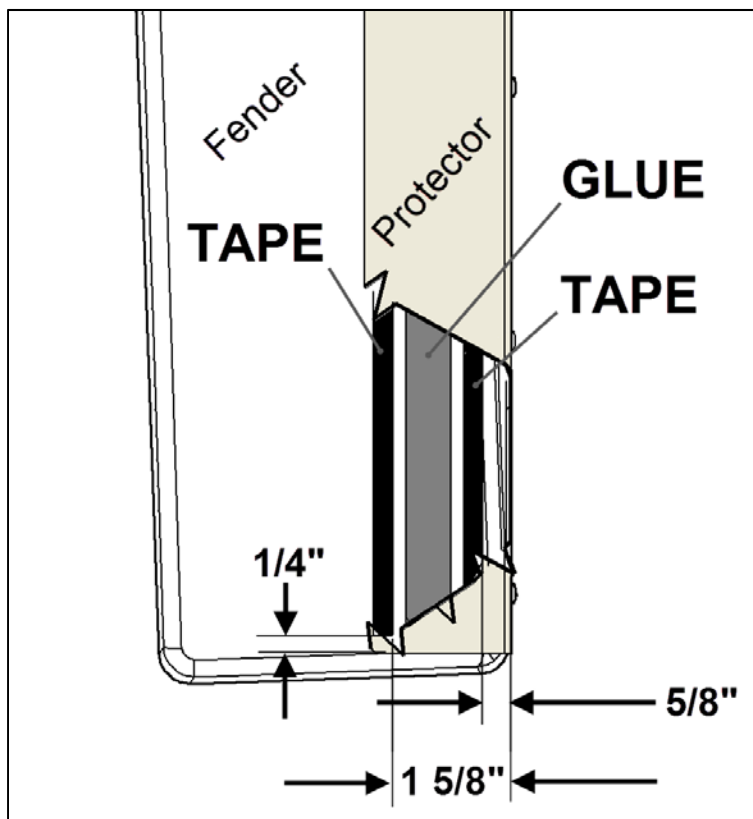

FIGURE 4 : TAPE PLACEMENT UNDER PROTECTOR.

10. Within 10 minutes of glue application, place protector against inner face of fender (1, Figure 5). Then, push against outer face (2, Figure 5).

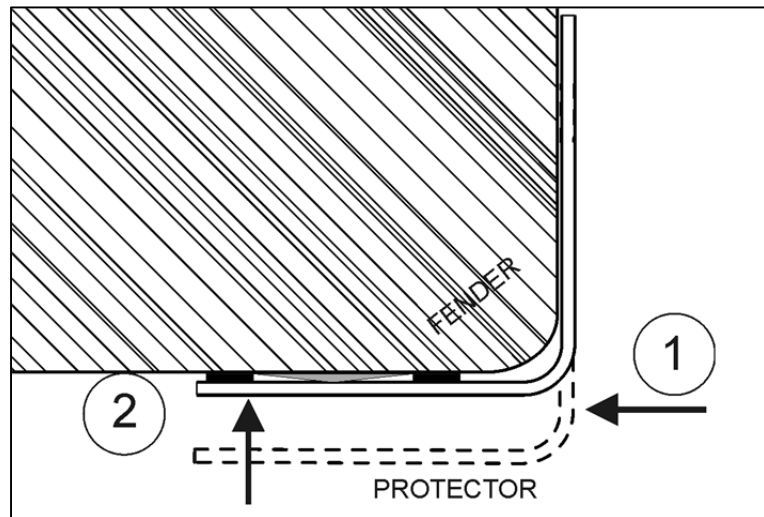

FIGURE 5 INSTALLATION SEQUENCE

11. Using the protector as a template, drill 1/8" holes for rivets. (5x)
12. Install the rivets.

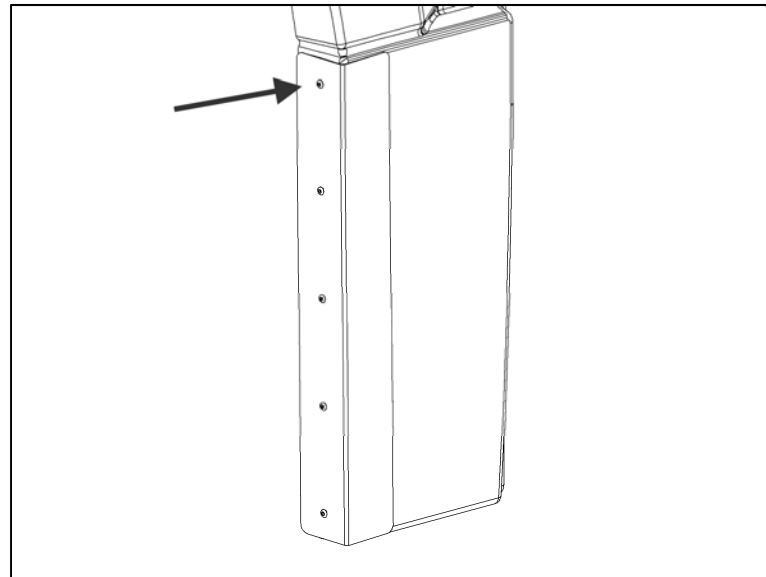

FIGURE 6

13. Full curing time: **9 1/2h @ 73°F (23°C), 50% Relative Humidity.**
Curing time may be shorter or longer depending on temperature and humidity.

PARTS / WASTE DISPOSAL

Discard waste according to applicable environmental regulations (Municipal/State[Prov.]/ Federal)