

- ATTENTION:**
- GENERAL MANAGER
 - PARTS MANAGER
 - CLAIMS PERSONNEL
 - SERVICE MANAGER

IMPORTANT - All Service Personnel Should Read and Initial in the boxes provided, right.

©2018 Subaru of America, Inc. All rights reserved.



QUALITY DRIVEN® SERVICE

SERVICE BULLETIN

APPLICABILITY: 2015-2018MY Legacy and Outback
 2012-2018MY Impreza
 2013-2018MY Crosstrek
 2014-2018MY Forester
 2015-2018MY WRX

NUMBER: 16-112-18R

DATE: 03/15/18

REVISED: 02/20/19

SUBJECT: Ignition Key Sticking / Design Change to CVT Shifter / Selector Lever Components

INTRODUCTION:

This bulletin announces a design change to the CVT select lever (shifter) mechanism in response to isolated customer concerns of not being able to remove the key from the ignition switch when the vehicle is in Park. The cause is contamination of the Park-Range switch internal components.

PRODUCTION CHANGE INFORMATION:

The new select lever components were incorporated into production as per the table below:

Vehicle / Model	Starting VIN
Legacy	J*017478
Outback	J*245513
Impreza 4-Door	J*605062
Impreza 5-Door	J*712211
Crosstrek	J*209256
Forester	J*441815
WRX	J*808100

PART INFORMATION:

IMPORTANT NOTES:

- The term PLATE-GUIDE B refers to the Park-Range switch which is a serviceable part of the select lever assembly on all models listed above **EXCEPT** Legacy and Outback. See the illustrations provided below for more details.

Continued...

<p>CAUTION: VEHICLE SERVICING PERFORMED BY UNTRAINED PERSONS COULD RESULT IN SERIOUS INJURY TO THOSE PERSONS OR TO OTHERS.</p> <p>Subaru Service Bulletins are intended for use by professional technicians ONLY. They are written to inform those technicians of conditions that may occur in some vehicles, or to provide information that could assist in the proper servicing of the vehicle. Properly trained technicians have the equipment, tools, safety instructions, and know-how to do the job correctly and safely. If a condition is described, DO NOT assume that this Service Bulletin applies to your vehicle, or that your vehicle will have that condition.</p>	<p style="text-align: center;">Subaru of America, Inc. is ISO 14001 Compliant</p> <p>ISO 14001 is the international standard for excellence in Environmental Management Systems. Please recycle or dispose of automotive products in a manner that is friendly to our environment and in accordance with all local, state and federal laws and regulations.</p>
--	--

- For **Legacy and Outback**, the shifter assembly (SELECT LEVER COMPLETE) must be replaced if the Park-Range switch is found to be faulty.

Description	Part Number	Applicability
PLATE-GUIDE B	35122FJ033	2012-2016MY Impreza
		2013-2017MY Crosstrek
		2014-2018MY Forester
		2015-2018MY WRX
	35122AJ162	2018MY Crosstrek
	35122FL00B	2017-2018MY Impreza
CLAMP	35164AJ000	1-Time Use items, must be replaced whenever installing PLATE-GUIDE B on above models, 1 of each required.
	35164AJ010	
SELECT LEVER COMPLETE	35111AL00B	2015-2017MY Legacy & Outback

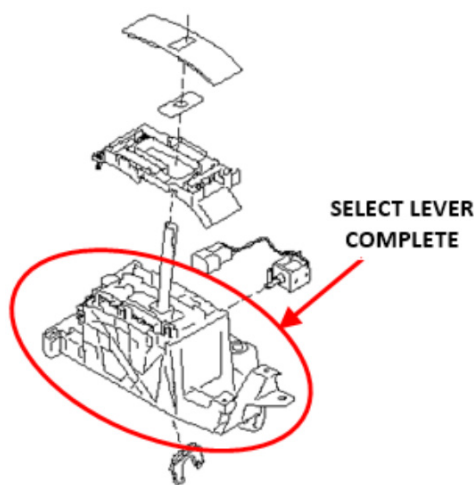

For Legacy and Outback:

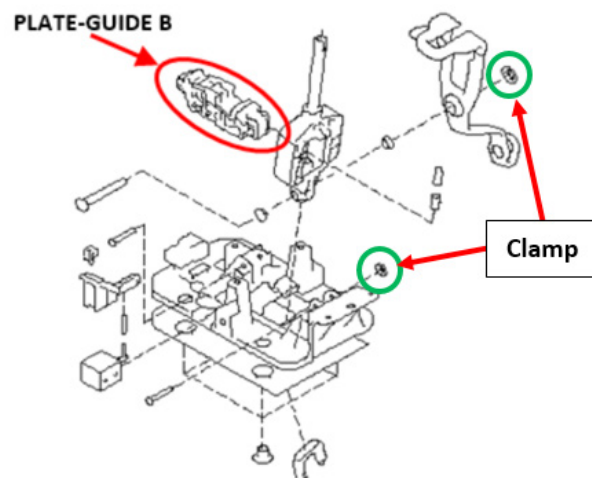

For all other models listed:

SERVICE PROCEDURE / INFORMATION:

NOTE: The diagnostics below were previously supplied in the June 2017 issue of TIPS.

- After confirming the customer concern of not being able to remove the key from the ignition switch, check the following PID for **Key lock solenoid output** (**Figure 1** below) in the Body Integrated Unit (BIU) current data display.

Figure 1

Key lock solenoid output	Key lock solenoid output ON/OFF status. Body integrated unit output value. Solenoid is activated to set this item to ON when the key is inserted with the shift lever in other than P range.	Lock/Unlock	Model without keyless access with push button start system
--------------------------	--	-------------	--

Continued...

- If the Key lock solenoid output is displayed as **Lock**, the next step in diagnosis should be to check the following PID (Figure 2 below).

Figure 2		
P SW	P range switch ON/OFF status. Body integrated unit input value. Set to ON in the P range.	ON/OFF

- P SW is the park range switch, located in the AT shifter assembly. If the shifter is in the Park position and this PID remains OFF, suspect an issue with either the park range switch or the related wiring. Check for drink spills, previous interior repairs, modifications and the shift lever position itself. Troubleshooting procedures can be found in the applicable Service Manual under the AT Shift Lock Control System > KEY INTERLOCK CANNOT BE LOCKED OR RELEASED.

After diagnosis has confirmed the Park-Range switch to be faulty, either:

- Replace the SELECT LEVER COMPLETE assembly (on Legacy and Outback models) or,
- Replace the Park-Range switch (PLATE-GUIDE B) following the Select Lever disassembly / assembly procedure in the applicable Service Manual.

IMPORTANT TIP: After removing the shift knob there will be a white plastic rod / plunger protruding from the top of the chrome lever. Use a permanent marker and mark its position as shown in the photo so it can be put back in the same place during reassembly. The bottom end has a notch in it which **must** be in the correct position for proper operation of the mechanism.

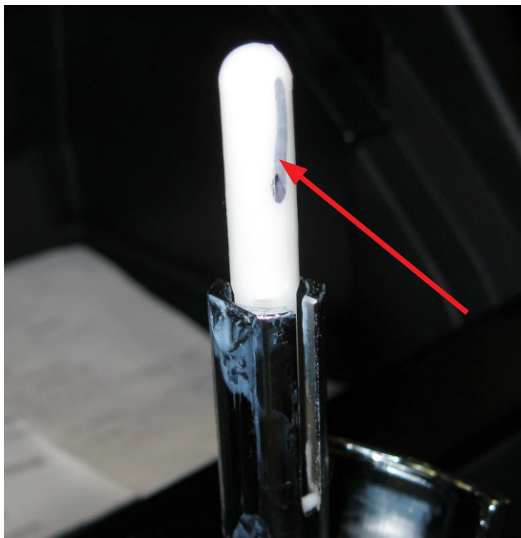

After Select Lever reassembly is complete, be sure to confirm the following:

- the combination meter indicator matches the select lever position when changing from “P” range to “D” range
- the select lever position and indicator match each other
- the select lever operates smoothly from “P” to “D” and back to “P” range
- the ignition key can be removed from the ignition lock when the vehicle is in Park.

Continued...

WARRANTY / CLAIM INFORMATION:

For vehicles within the Basic New Car Limited Warranty period or covered by an active Subaru Added Security Gold plan, this repair may be submitted using the following claim information:

Labor Description	Labor Operation #	Labor Time	Fail Code
A/T SHIFT LOCK TESTING	B308-001	0.4	MJX-43
PARK-RANGE SWITCH (SELECT LEVER COMPLETE) R&R LEGACY & OUTBACK ONLY	C308-161	0.6	
PARK-RANGE SWITCH R&R, (ALL OTHER MODELS LISTED IN THIS BULLETIN)		1.3	

IMPORTANT REMINDERS:

- SOA strongly discourages the printing and/or local storage of service information as previously released information and electronic publications may be updated at any time.
- Always check for any open recalls or campaigns anytime a vehicle is in for servicing.
- Always refer to STIS for the latest service information before performing any repairs.