

- ATTENTION:**
- GENERAL MANAGER
  - PARTS MANAGER
  - CLAIMS PERSONNEL
  - SERVICE MANAGER

IMPORTANT - All Service Personnel Should Read and Initial in the boxes provided, right.

© 2018 Subaru of America, Inc. All rights reserved.



QUALITY DRIVEN® SERVICE

## SERVICE INFORMATION BULLETIN

**APPLICABILITY:** 2017-2018MY Impreza  
2018MY Crosstrek

**NUMBER:** 07-141-18

**DATE:** 10/15/18

**SUBJECT:** Engine Harness Retaining Clip Change

### INTRODUCTION:

This Service Information Bulletin announces a change to the retaining clip used to secure the engine harness on the models listed above. The change to a “Tree Type” clip from an “Anchor Type” was made to secure the harness tighter and improve assembly line productivity. Comparison images are provided below.

### PRODUCTION CHANGE INFORMATION:

The new clip was incorporated into production per the table below:

Model	Starting VIN
Impreza 4-Door	J3614364
Impreza 5-Door	J3730861
Crosstrek	J8266602

### PART INFORMATION:

In a RARE case where the harness clip requires replacement, the new part number is: **24226AA310**.

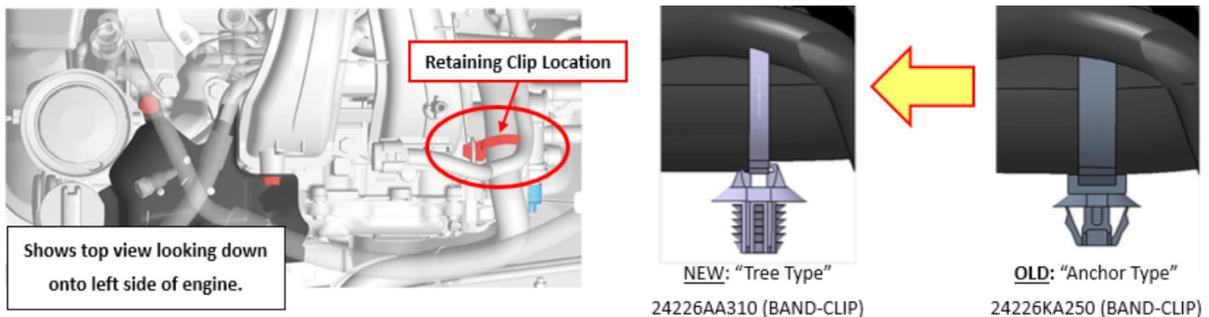

*Continued...*

**CAUTION: VEHICLE SERVICING PERFORMED BY UNTRAINED PERSONS COULD RESULT IN SERIOUS INJURY TO THOSE PERSONS OR TO OTHERS.**

Subaru Service Bulletins are intended for use by professional technicians ONLY. They are written to inform those technicians of conditions that may occur in some vehicles, or to provide information that could assist in the proper servicing of the vehicle. Properly trained technicians have the equipment, tools, safety instructions, and know-how to do the job correctly and safely. If a condition is described, DO NOT assume that this Service Bulletin applies to your vehicle, or that your vehicle will have that condition.

**Subaru of America, Inc. is ISO 14001 Compliant**

ISO 14001 is the international standard for excellence in Environmental Management Systems. Please recycle or dispose of automotive products in a manner that is friendly to our environment and in accordance with all local, state and federal laws and regulations.

## SERVICE PROCEDURE / INFORMATION:

**REMINDER:** Customer satisfaction and retention starts with performing quality repairs.

Always refer to the applicable Service Manual and review the full requirements of the repair being performed. The Service Manual procedures contain information critical to performing an effective repair the first time and every time. This includes but is not limited to: important SAFETY precautions, proper inspection criteria, necessary special tools, required processes and related one-time-use parts needed for a complete and lasting repair.

### IMPORTANT:

- Whenever removing the clip from the mounting bracket, ALWAYS use a clip removal tool as shown in the illustrations below to avoid damaging it.
- When installing the clip, it must be inserted into the bracket firmly with no more than 3MM clearance between the bracket and the underside of the clip.

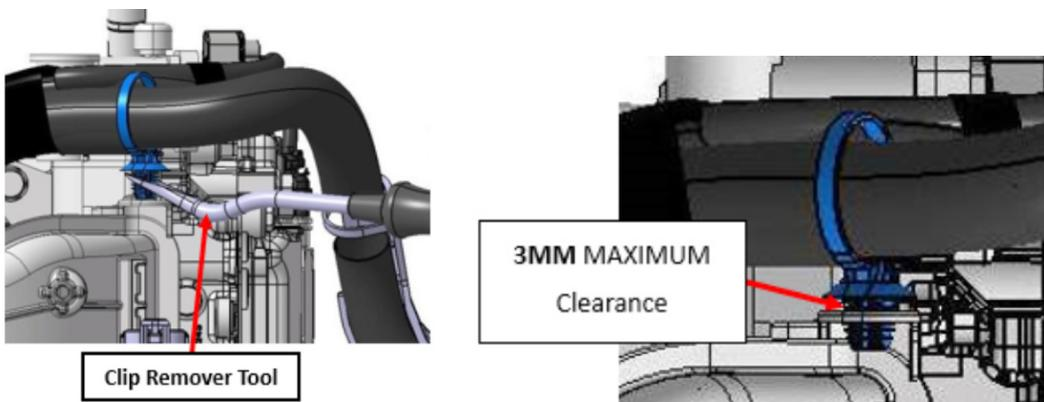

**NOTE:** If the clip is replaced, put a reference mark on the harness before removing the original so the new clip can be positioned properly. After tightening the band of the new clip around the harness, trim off any excess (5mm max.) band remaining.

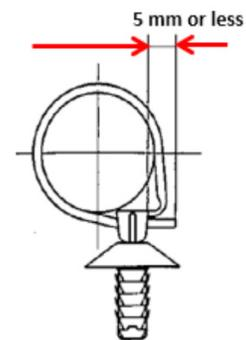

### IMPORTANT REMINDERS:

- SOA strongly discourages the printing and/or local storage of service information as previously released information and electronic publications may be updated at any time.
- Always check for any open recalls or campaigns anytime a vehicle is in for servicing.
- Always refer to STIS for the latest service information before performing any repairs.