



Preliminary Information

PIT5438E Click / Rattle / Tick / Pop / Creak / or Squeak Noise from Dash Area

Models

| Brand: | Model: | Model Years: | VIN: | | Engine: | Transmissions: |
|-----------|---------------------|--------------|------|-----|---------|----------------|
| | | | from | to | | |
| Cadillac | Escalade | 2015 - 2019 | All | All | All | All |
| Chevrolet | Silverado 1500 | 2014 | All | All | All | All |
| Chevrolet | Silverado | 2015 - 2018 | All | All | All | All |
| Chevrolet | Silverado 1500 LD | 2019 | All | All | All | All |
| Chevrolet | Suburban | 2015 - 2019 | All | All | All | All |
| Chevrolet | Tahoe | 2015 - 2019 | All | All | All | All |
| GMC | Sierra 1500 | 2014 | All | All | All | All |
| GMC | Sierra | 2015 - 2018 | All | All | All | All |
| GMC | Sierra 1500 Limited | 2019 | All | All | All | All |
| GMC | Yukon | 2015 - 2019 | All | All | All | All |

Supersession Statement

This PI has been updated to add condition 7 and add a graphic and update model years. Please discard PIT5438D.

The following diagnosis might be helpful if the vehicle exhibits the symptom(s) described in this PI.

Condition / Concern

Condition 1: Tinny or metallic rattle type noise from the IP area to the left of the steering column.

The noise may be caused by the 110 Volt Power Inverter Module not being seated properly in the mounting bracket (if equipped with RPO K14).

Condition 2: Rattle, squeak or itch type noise from the center of the dash in the radio area.

The instrument panel accessory bezel may be rattling due to insufficient tension of retainers. Press on the bezel while duplicating noise to see if it is eliminated.

Condition 3: Rattle or itch type noise from the dash area near the windshield

Defroster grill may be rattling due to insufficient retention of retainers. Press on defroster grill (# 1 in illustration) while duplicating concern to see if it is eliminated.

Condition 4: Rattle, tick, knock type noise from the front center floor or center of dash area (Applies to trucks equipped with

center console subwoofer speaker)

This concern could be caused by the radio subwoofer speaker mounting nuts either being loose or missing.

Condition 5: Creak, ticking or popping type noise heard from the left center stack area. (This issue only applies to Full Size Utilities built before November 18, 2016)

This concern could be caused by the use of an incorrect screw that secures the instrument panel carrier in place. The screw that may have been used is too long, and it may contact the instrument panel tie bar. In some cases, this noise may only occur after the vehicle has been driven for a period of time.

Condition 6: Chirp or squeak noise coming from the lower left side of the center stack area.

This concern could be caused by loose retaining nuts on the chassis harness retention bracket that is located below the brake booster.

Condition 7: Rattle noise coming from the drivers footwell area.

This concern could be caused by the IP junction block cover moving and causing a rattle noise.

Recommendations / Instructions

Correction 1 (for vehicles equipped with 110 Volt AC Converter - RPO K14):

Follow SI to locate the Accessory AC and DC Power Control Module located to the right of the steering column.

See #1 in photos below:

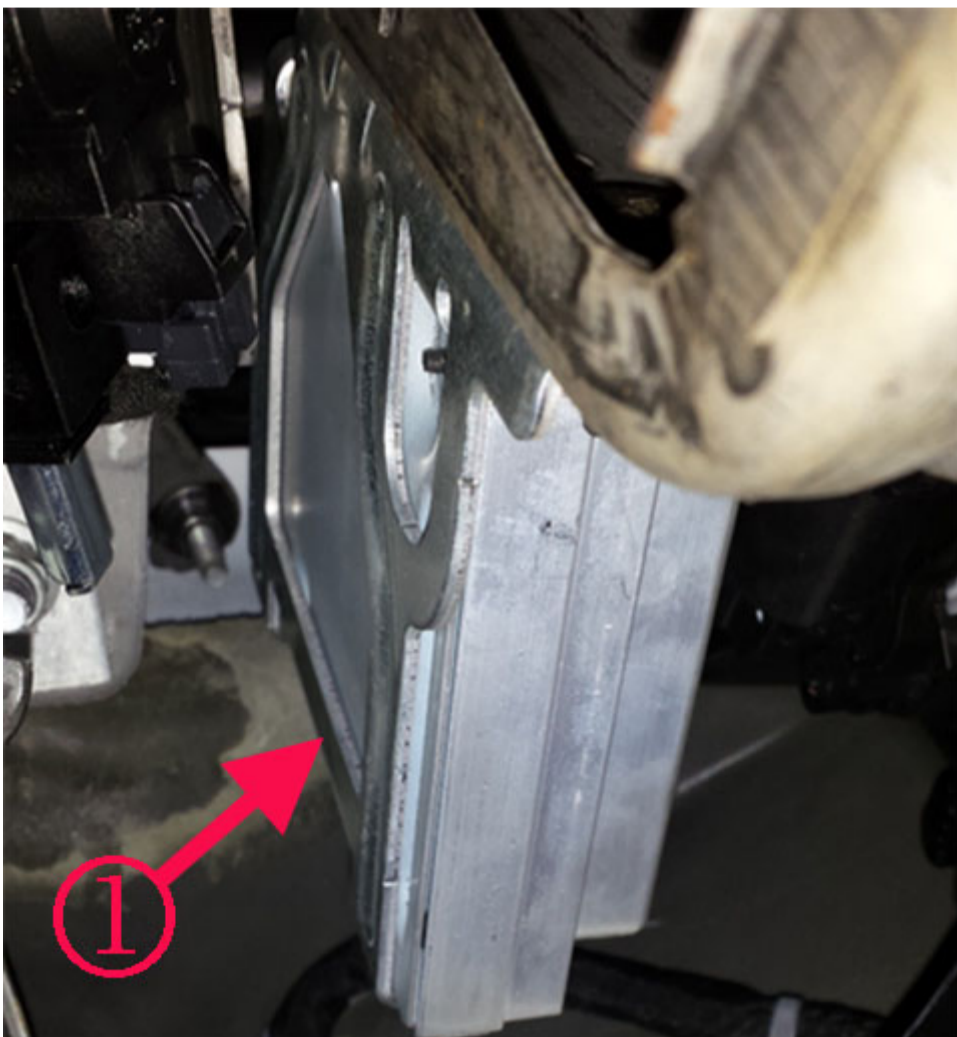



Inspect the power inverter module for possibly moving slightly against mounting bracket and creating the noise.

Remove the K14 power inverter module and apply two sided tape to the module bracket to insulate it from the mount.

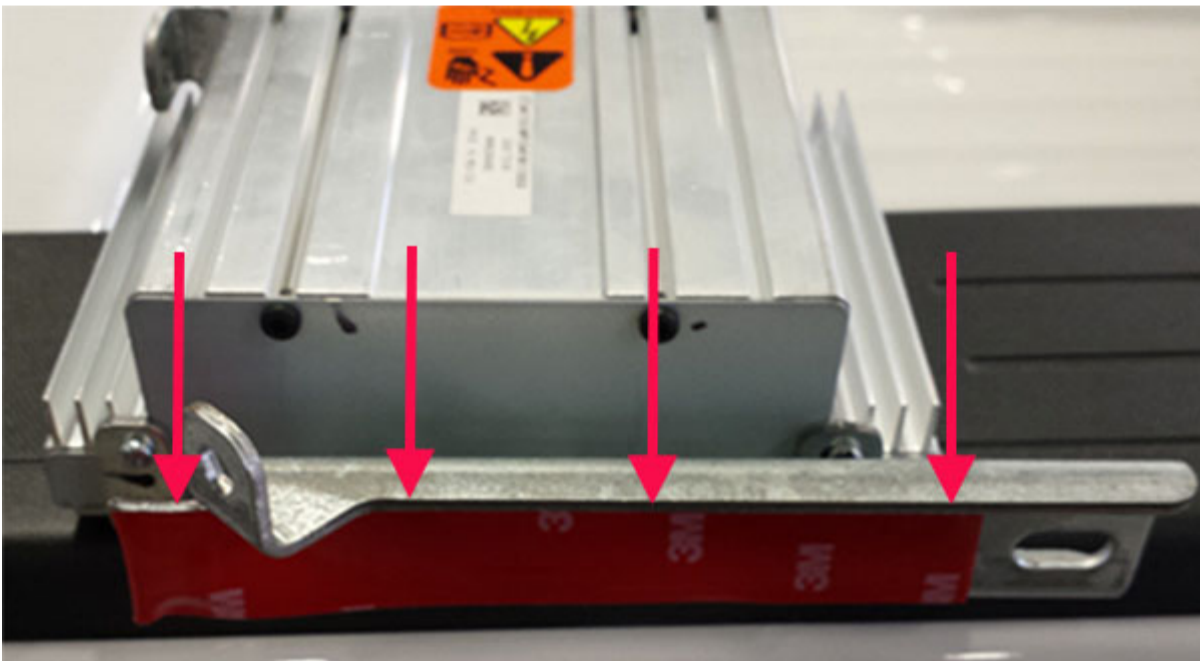

Two sided tape is available through Kent Automotive, part # P40519 which is a ½" x 50' roll or it may be obtained locally.

Correction 2:

Wrap Kent automotive BRS flocking tape part number KT13487 over retainers (#1 in illustration) and reinstall bezel.

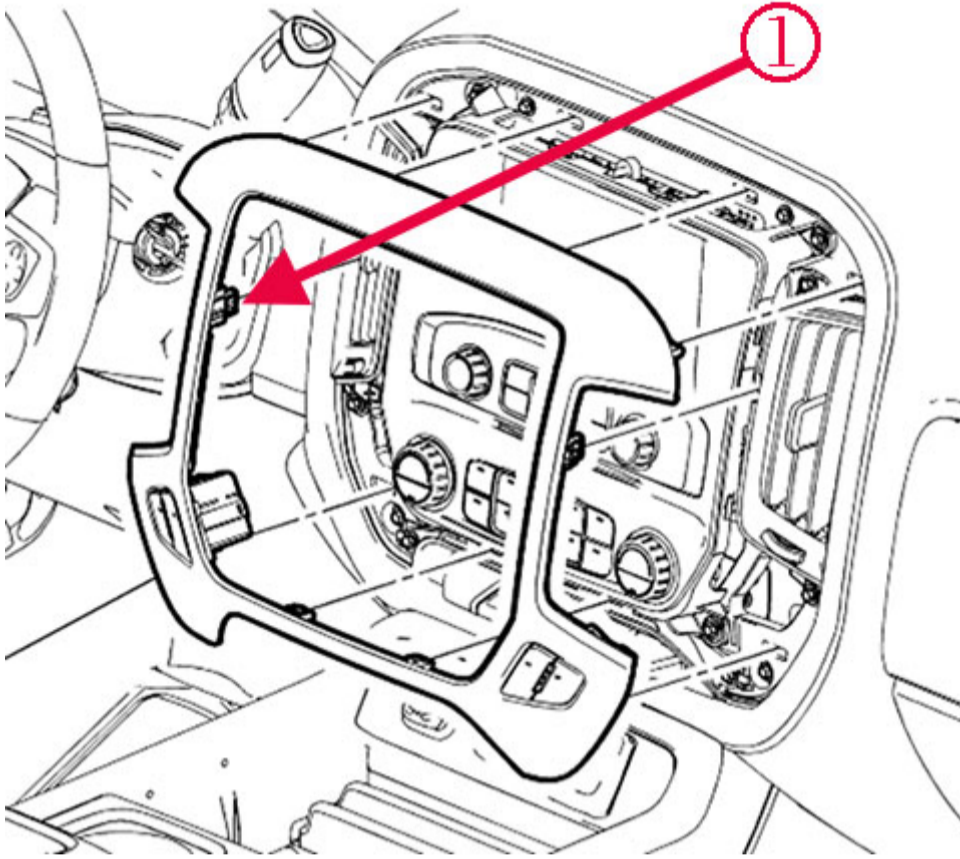

This will require an application of BRS flocking tape on ten retainers (one strip @ 1" x 10").
Two sheets should repair 16 vehicles.

Correction 3:

Remove defroster grill.

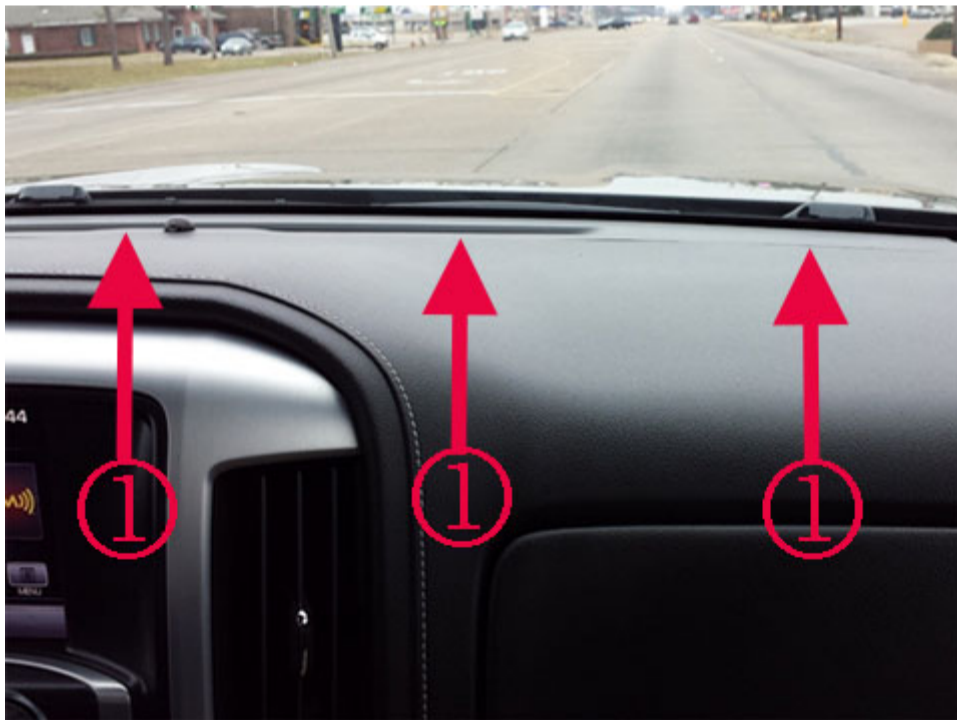

Apply foam tape around connectors located under grill to prevent them from rattling on grill.
See # 1 in illustrations.

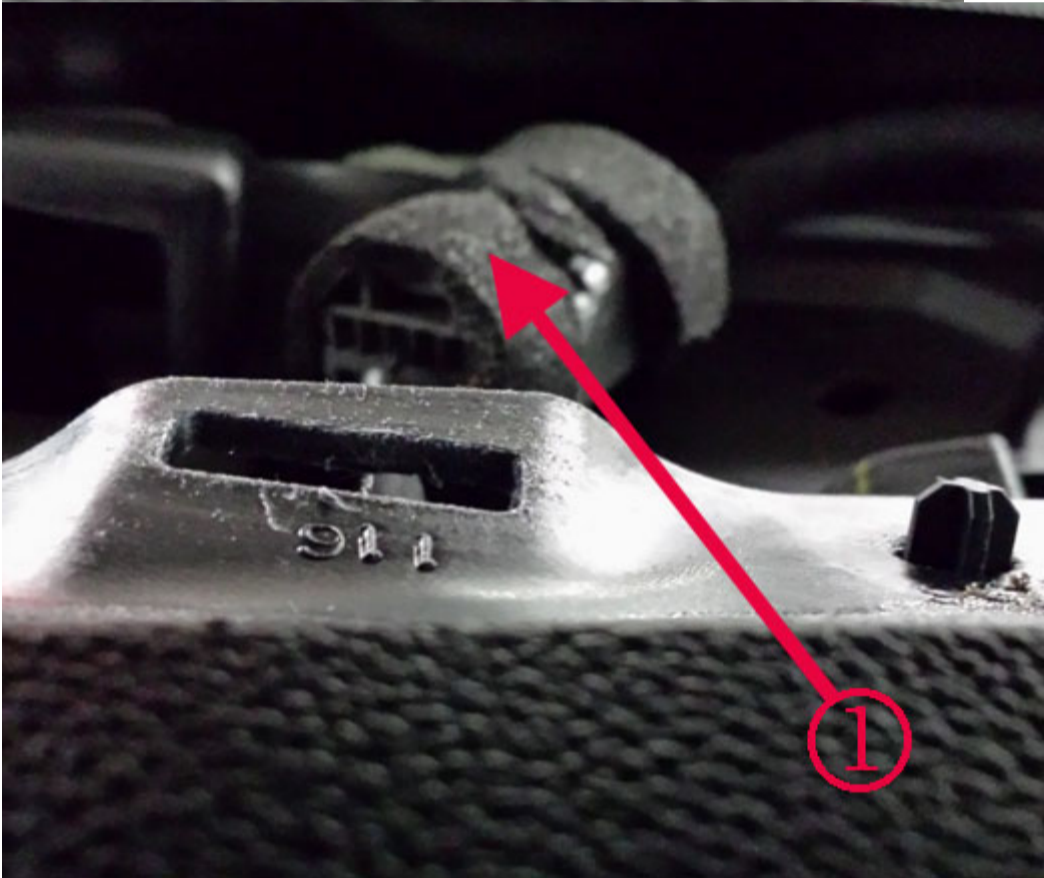
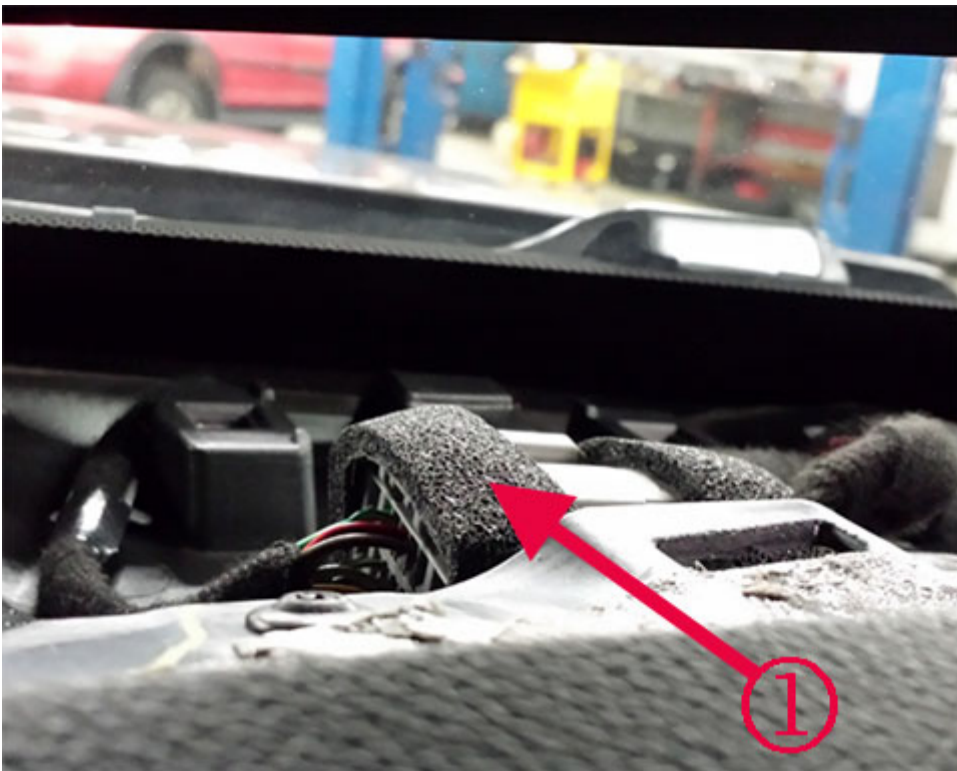

Apply foam tape to all mounting hooks in the front of the defroster grill # 1 and apply a strip of foam tape along the edge of the grill to isolate the grill from the dash #2.

Wrap Kent automotive BRS flocking tape part number KT13487 over the metal retaining tabs that secure defroster grill in position #3.

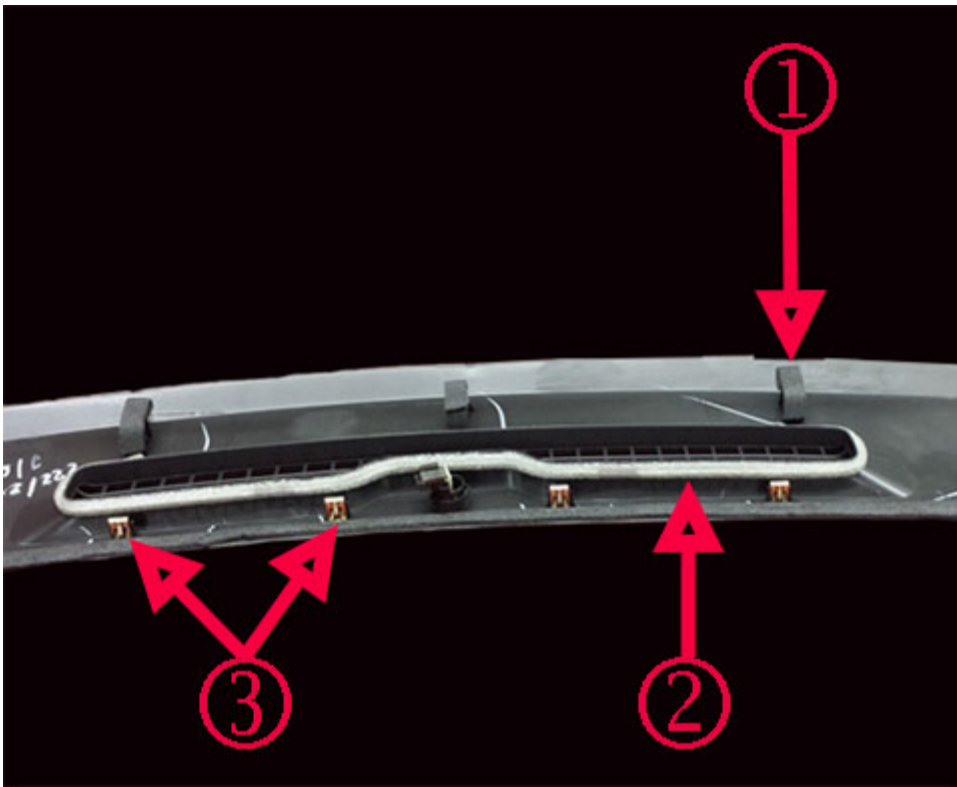

Foam tape can be obtained from Kent Automotive, part # KT15103 (40 ft roll) or it may be obtained locally.

This repair will require 1 ½ meters with a 40 foot roll covering approximately 25 vehicles per roll. There are 22 retaining tabs that will each require an application of 1" of BRS flocking tape for a total of 20". Two sheets will repair 7 vehicles.

Correction 4:

To correct this issue, inspect the center console subwoofer speaker (2) mounting nuts (1) for being loose or missing. Subwoofer speaker mounting is shown below. Install and tighten the subwoofer speaker mounting nut(s) to 6 Nm (53 lb in).

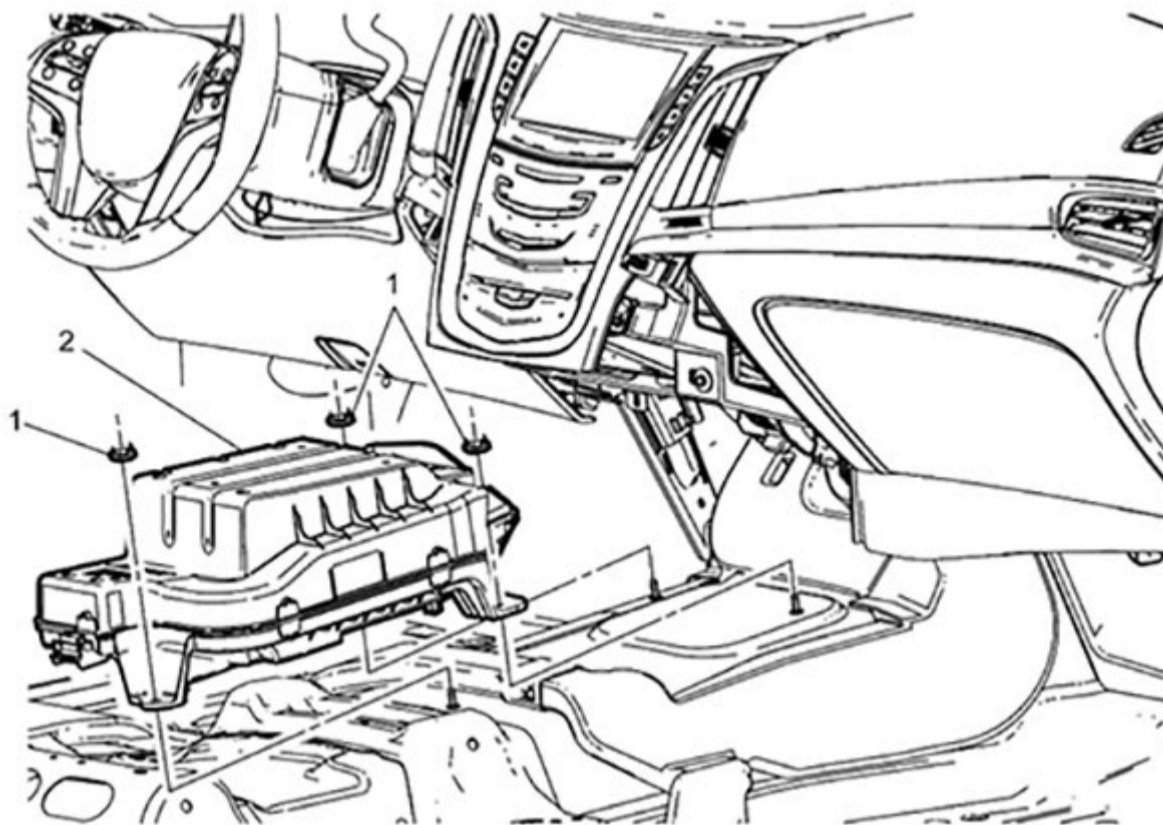

Correction 5: (This issue only applies to Full Size Utilities built before November 18, 2016)

The screw shown in the photos below may be too long and the screw tip actually contacts the instrument panel tie bar. This contact is shown as item #4 below. This screw secures the instrument panel carrier to the instrument panel tie bar.

Chevrolet/GMC models are shown as item# 1 and a close-up of this fastener can be seen as item #2. Replace this screw with a shorter fastener, GM part number 11547755, which is approximately 24 mm in length.

Cadillac models can be seen in item #3 below. Replace this screw with a shorter fastener, GM part number 11547755, which is approximately 24 mm in length as well.

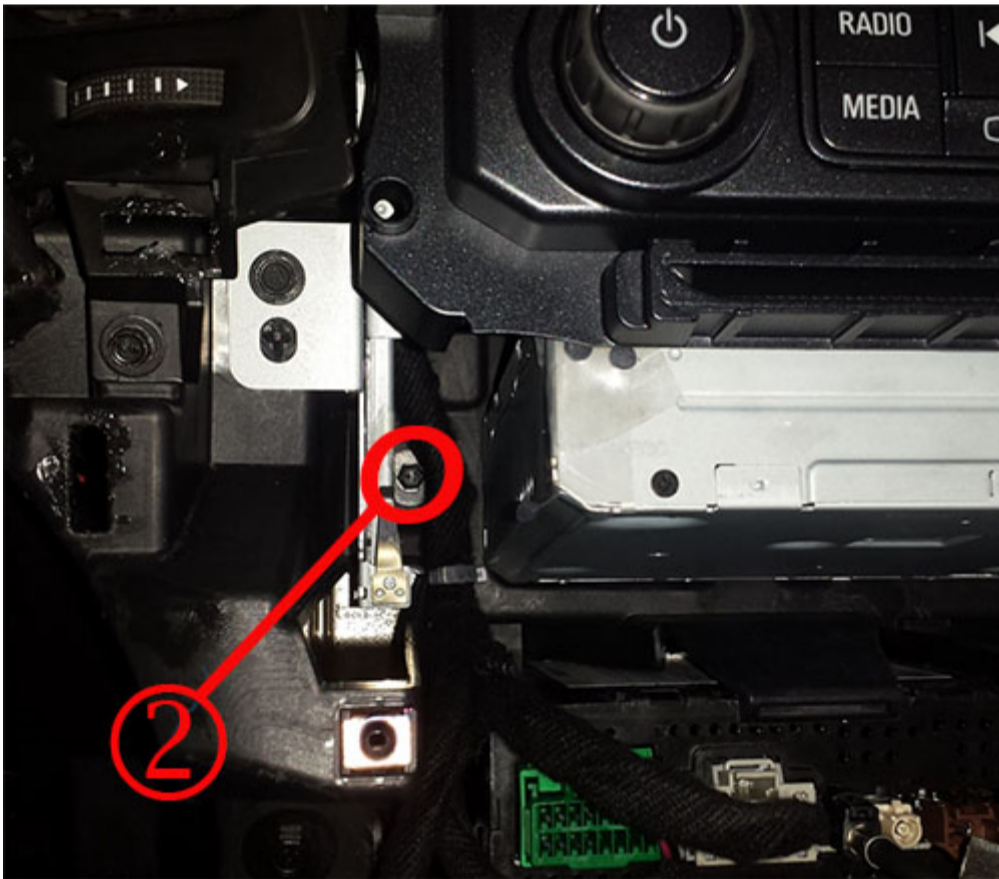

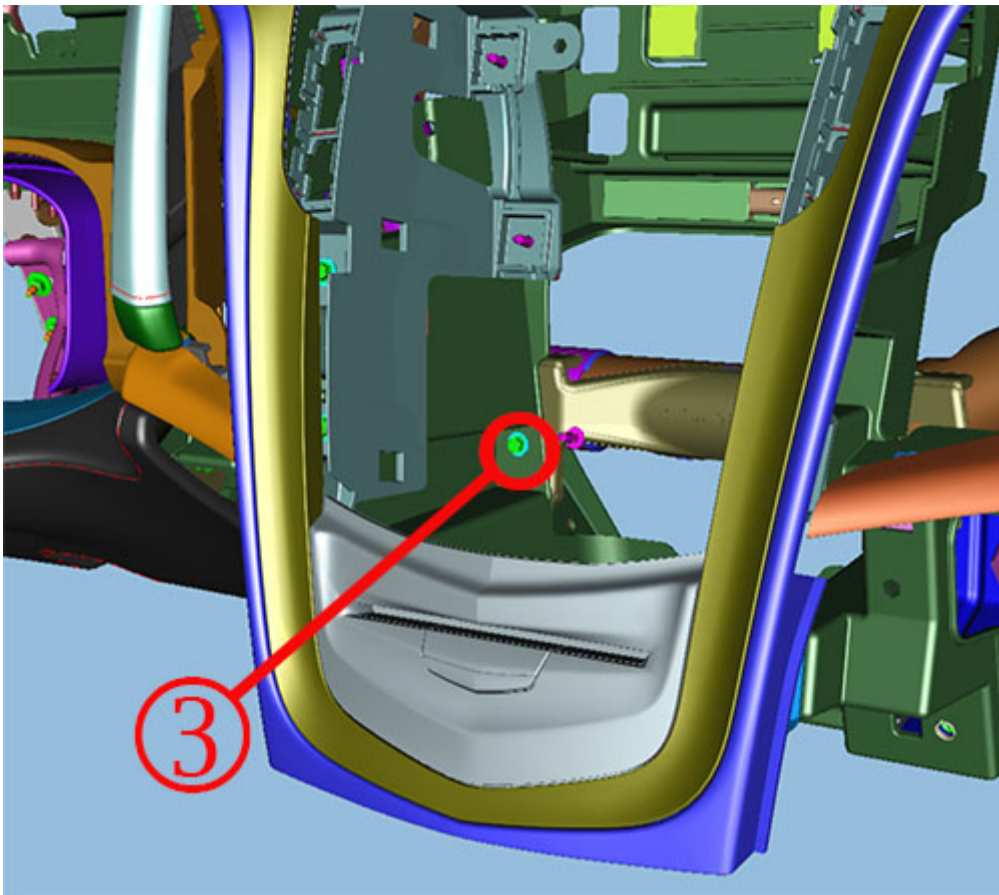

Correction 6:

The following picture shows the chassis harness retaining bracket and nuts (2) below the brake booster (1). Verify the retaining nuts are tight.

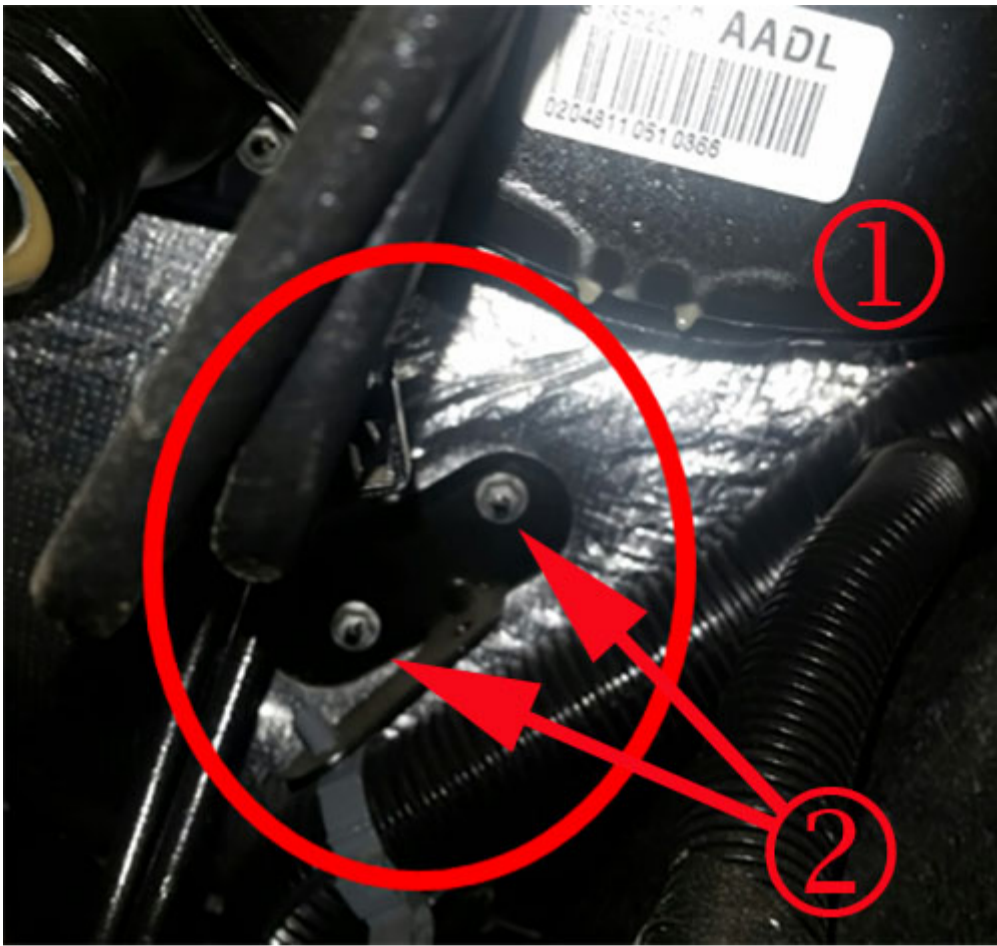

Correction 7:

To correct this issue use foam tape to insulate the IP junction block cover to prevent movement which is causing the rattle type noise.

Parts Information

| Part Number | Description | Qty |
|---|--|-------------|
| * P40519 | Two Sided Tape | As Required |
| * KT13487 | BRS Flocking Tape | As Required |
| * KT15103 | Foam Tape | As Required |
| 11547755 | Screw - Instrument panel carrier to instrument panel tie bar | 1 |
| * Contact Kent Automotive at 1-888-YES-KENT ☎ or online at www.kent-automotive.com | | |

Warranty Information

For vehicles repaired under warranty, use:

| Labor Operation | Description | Labor Time |
|-----------------|---|------------------------------------|
| 5420220 | Condition 1 Accessory AC and DC Power Control Module Replacement | Use Published Labor Operation Time |
| 1030730 | Condition 2 Instrument Panel Accessory Bezel Replacement | Use Published Labor Operation Time |
| 1032590 | Condition 3 Instrument Panel Extension Replacement | Use Published Labor Operation Time |
| 3421660 | Condition 4 Radio Front Floor Console Speaker Replacement | Use Published Labor Operation Time |
| 1080418* | Condition 5 | 1.2 hrs |

| | | |
|---|---|---|
| | Replace one instrument panel carrier to instrument panel tie bar screw | |
| 5430170 | Engine wiring harness junction replacement | Use Published Labor Operation Time |
| 1030630 | Condition 7 Instrument panel fuse block access hole cover replacement | Use Published Labor Operation Time |
| * This is an unique labor operation for bulletin use only. This will not be published in the Labor Time Guide. | | |

Please follow this diagnostic or repair process thoroughly and complete each step. If the condition exhibited is resolved without completing every step, the remaining steps do not need to be performed.



GENERAL MOTORS

© 2018 General Motors. All Rights Reserved.