



**NEW FLYER**

## ***SERVICE MANUAL BULLETIN***

This Service Manual Bulletin is prepared by the Publications Department of New Flyer Industries Canada ULC. Refer to details below.

### **SMB-128**

ISSUE DATE: Sep 13 2013

<b>APPLICABILITY</b>					
<b>VEHICLE LENGTH</b>	<input type="checkbox"/> 30ft.	<input type="checkbox"/> 35ft.	<input type="checkbox"/> 40ft.	<input type="checkbox"/> 60ft.	<input checked="" type="checkbox"/> ALL
<b>VEHICLE TYPE</b>	<input type="checkbox"/> High Floor	<input checked="" type="checkbox"/> Low Floor	<input type="checkbox"/> Invero	<input checked="" type="checkbox"/> Xcelsior	<input type="checkbox"/> ALL
<b>FUEL TYPE</b>	<input type="checkbox"/> Diesel	<input type="checkbox"/> Electric	<input type="checkbox"/> CNG	<input type="checkbox"/> LNG	<input checked="" type="checkbox"/> ALL
	<input type="checkbox"/> Diesel/Electric	<input type="checkbox"/> Gas/Electric	<input type="checkbox"/> Fuel Cell		
<b>SUBJECT</b>	<b>Door Sensitive Edge Preventive Maintenance &amp; Functional Test</b>				
<b>SECTION TITLE</b>	<b>16 - Entrance &amp; Exit Doors</b>				
<b>DETAILS</b>	<p>This bulletin provides revised information on testing the sensitive edges located on the exit door as installed on your New Flyer vehicle.</p> <p>This information supersedes any prior information on this subject already provided in your New Flyer Manuals. Make this Service Bulletin available to service personnel to inform them of changed information.</p>				



# 1. Door Sensitive Edge Inspection & Test

## 1.1. Preventive Maintenance

Inspect and test the door sensitive edge function daily and perform a complete inspection every year or 100,000 miles (160,000 km), whichever occurs first. Visually inspect door sensitive edge for cuts, tears, or other damage. Replace sensitive edge if damaged.

- Inspect for properly connected tubing from sensitive edge to pressure wave switch.
- Inspect electrical connections on pressure wave switch.
- Perform a functional test on the sensitive edge system as outlined in the following Functional Test procedure

## 1.2. Functional Test

1. Ensure that the system is at full air pressure, the vehicle is parked and the parking brake is set
2. Open the doors to be checked.
3. Set the doors to close.
4. Standing outside the bus and while the doors are closing, firmly pinch the sensitive edge seal on the left hand door panel. The doors should reopen. See "Fig. 1: Pinch Test."
5. Repeat steps 3 and 4 for the right hand door panel.
6. Standing outside the bus with the door closing, hold a 1 inch diameter rod (hardwood or metal approx. 18 in. (45.72 cm) long) perpendicular to the side of the bus at the vertical centerline of the door opening, 12 inches above the bottom of the door panels. See "Fig. 2: Rod Test."
7. The doors should reopen when the door edges contact the rod.
8. Repeat steps 6 and 7 two more times. First with the rod held at the mid point of the door opening and again with the rod held

at a point 12 inches below the top of the door panels.

9. If the doors open when tested according to steps 4 through 8, the sensitive edge system is working properly.
10. If the doors fail to open at any testing step, this may indicate a problem with a component of the sensitive edge system (sensitive edge seals, pressure wave switches, tubing or connection point). Verify proper operation of these components and then repeat this test procedure.

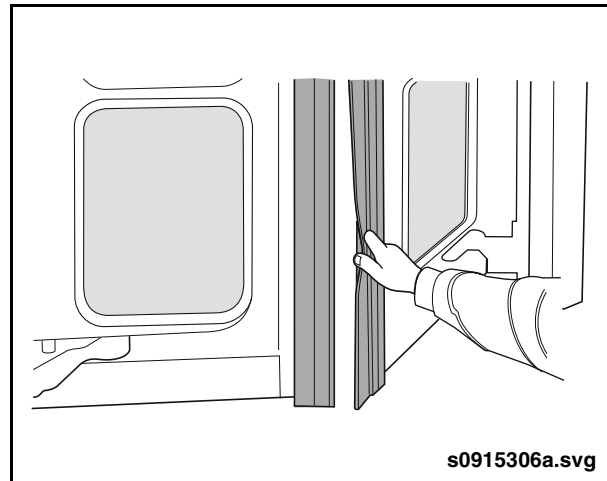

Fig. 1: Pinch Test

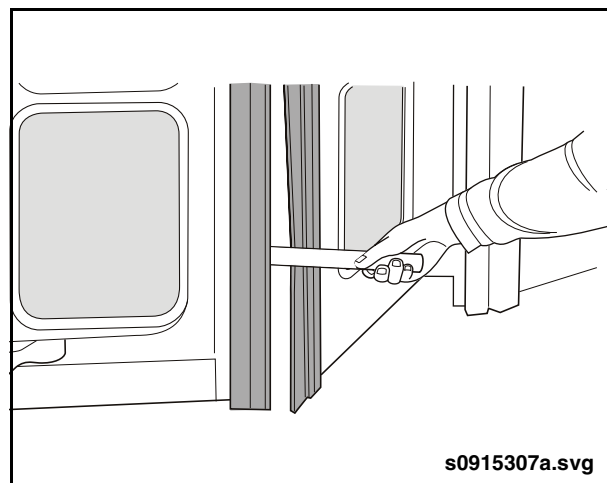

Fig. 2: Rod Test