

HDSS™

HEAVY DUTY SUSPENSION SYSTEM

SMOOTH OUT THE TOUGHEST ROADS

HDSS SPECIFICATIONS

- Provides the ability for axle alignment through the adjustable trailing rods reducing dog tracking and increasing tire life
- Heavy duty mechanical suspension designed for axles from 10,000 to 25,000 lbs. in tandem sets
- Industry standard 49.00" axle spacing provides better load balance and trailer stability
- Double slipper springs for better tracking and less maintenance
- Heavy duty hangers and equalizers are made from high yield fabricated light weight steel resulting in a lighter more durable trailer suspension
- Extended life equalizer bushing leads to lower maintenance time and cost
- 5-year limited warranty on suspension system combined with original Dexter axles

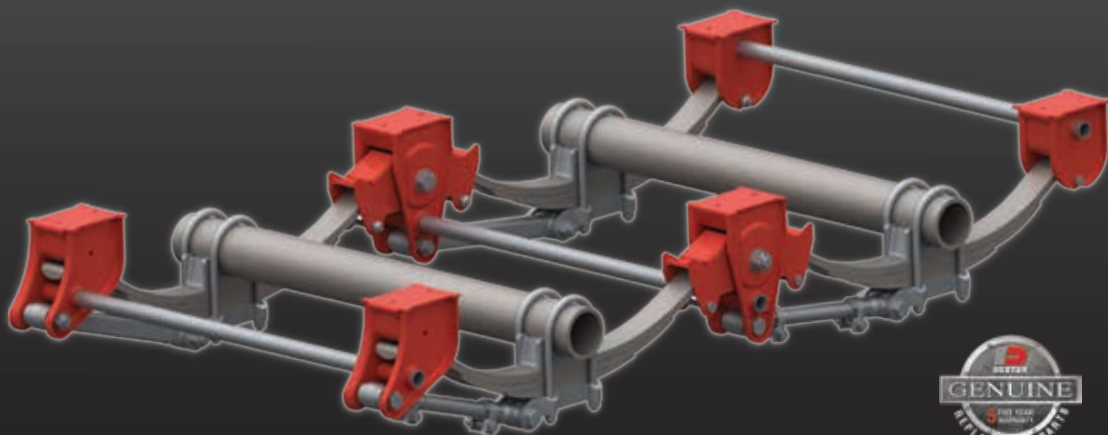

ISO 9001:2015 Certified

