

L83X-
A.07.14
+
L83X-
A.08.14

To: Official After Sales Network
Subject: Coolers and air ducts replacement
Date: 11/07/14
Pages: 11



Subject
Coolers and air ducts replacement

Model
All Lamborghini Model Aventador LP-700 MY 12 13 e 14 Coupè e Roadster from VIN CLA00091 to VIN ELA02377.

Warning: some vehicles included in this VIN range may not be involved, so check carefully on the Lamborghini WEB Portal (at the section named VIN Info) if the cars in your workshop or in your dealer stock are involved before performing any other operation.

Information to the field
As a result of continuous product monitoring, Automobili Lamborghini Spa has found that on some vehicles used in hot climate may slightly leak.

Field solution
Replace coolers and their ducts.

Spare Parts

P/N	Description	Q
OR8340120	Air duct and cooler kit:	1
	- RH air duct;	(1)
	- LH air duct;	(1)
	- cable tie;	(8)
	- Clamp;	(3)
	- A/C sealing;	(1)
	- m16x11 plug;	(1)
	- sealing washer	(1)
	- RH water cooler	(1)
	- LH water cooler	(1)

Replaced parts management.
Store replaced parts properly, and tagged them with bar code for their identification during Area Manager visits.

Warranty Claim data
The warranty reimbursement request for this rework action will be managed by the following standard Warranty Claim procedures.

A. Aventador Coupe MY 2012:
Campaign Code: L83X-A.07.14
Campaign Des.: Coolers and air ducts replacement.
Cost code: 50
Component code: CCAX0714
Trouble code: 220
Labor code: CCA0714100
Labor Time: 7 h

B. Aventador Coupe and Roadster MY 2013 and beyond:
Campaign Code: L83X-A.08.14
Campaign Des.: Coolers and air ducts re-placement.
Cost code: 50
Component code: CCA0814
Trouble code: 220
Labor code: CCA0814100
Labor Time: 7,2 h

Remember to fill all data in the section “Service and Recall Campaign” in the War-ranty booklet of the vehicle as shown below.



Repair instructions:

WARNING.



Operations to be performed at cold engine!

1. Secure vehicle to the lift appropriately before jacking in order to work safe from risks.
2. Trunk closing frame disassembly.

Remove 6 screws that fix front hood cover and then the cover itself.

Screw tightening.

Torque: **2.5 Nm.**



3. Trunk disassembly.

Unscrews 4 screws. .

Screw tightening.

Torque: **8 Nm.**

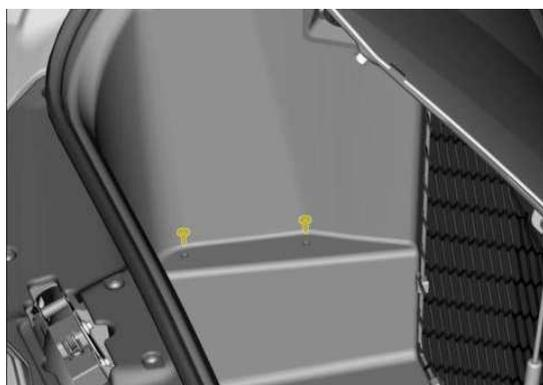

Lift trunk and disconnect plug from the 12V socket.

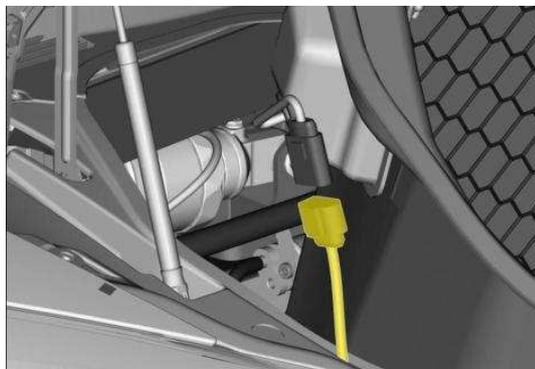

Remove trunk to get access to battery.



4. A/C system discharge.

- Connect hoses of A/C charging station to vehicle through HP and LP quick connectors.
- Operate phase of refrigerant fluid savage.



5. Rear tire disassembly.



Remark.

In order to avoid rims and brake discs damages use centring tool (p/n. 65395009) as shown in picture. This procedure must be performed on both sides.

Wheel bolt tightening.
Torque: **160 Nm**



6. Wheelhouse disassembly.

Each wheelhouse panel consist of 2 sections front and rear. It is recommended to disassemble both elements.

Screw tightening.
Torque: **9Nm M6 screws,
5Nm others.**



7. Flat central bottom disassembly.

Unscrew 16 screws so remove the central panel section.

Tightening screw.
Torque: **9 Nm.**

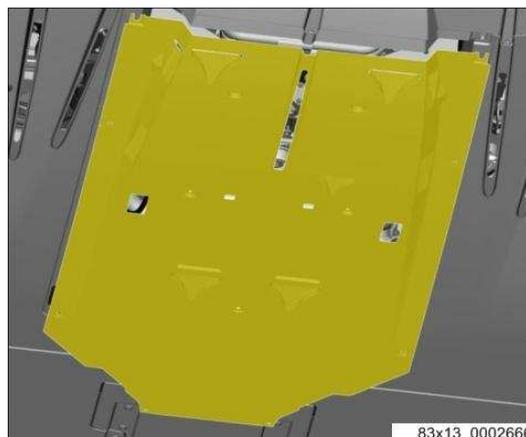

8. Side flat bottom disassembly.

Remove 11 screws then take side flat bottom panel.



Remark.

Perform this operation on both vehicle sides.

Screw tightening.
Torque: **9 Nm**

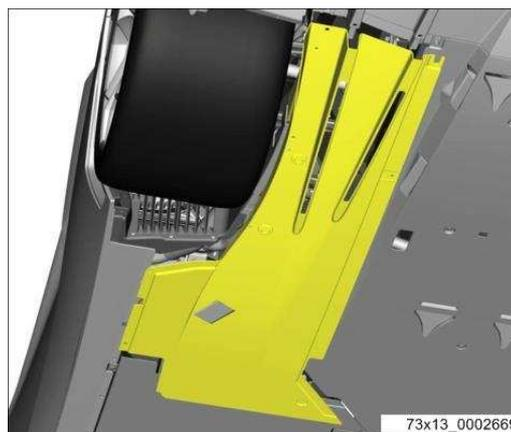

9. Cooling system draining.

Twist coolant cap off .

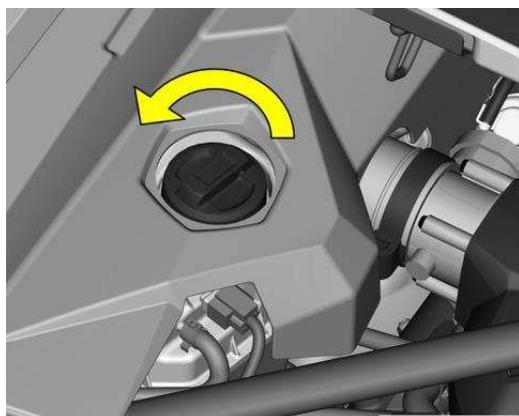

Prepare a suitable container to collect fluids, then remove coolant drain plug.



Remark.

It is necessary to replace draining plug and sealing while reassembling.

Plug tightening.

Torque: **23Nm.**

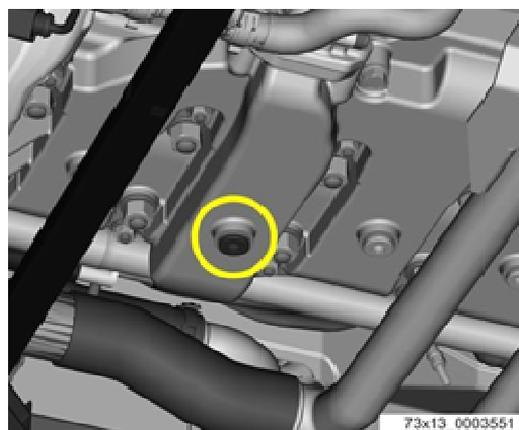

Remark.

Be extremely careful in avoiding coolant contamination, because it will be re-used.
Before starting engine up, perform draining and refilling then twist coolant tank cap on.

Left side operation.

10. Disassembly of E-GEAR control unit bracket.

Remove 2 nuts and then take ecu bracket off.

Free control unit from rear mount and lean it on suspension arm.

Nut tightening.

Torque: **9Nm.**



Remark.

Be extremely careful **to not disconnect** E-gear control unit plug and not damage it.

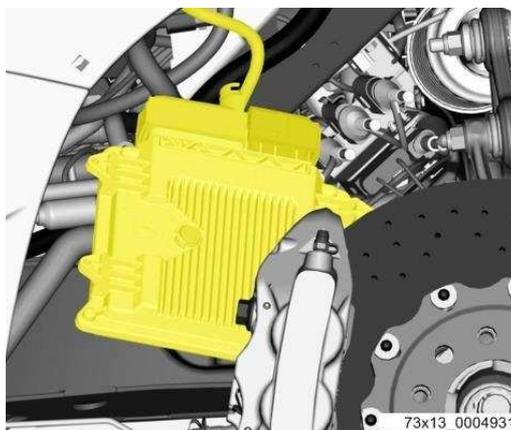

11. Disassemble of left cooler assembly.

Disconnect plug of electric radiator fan, remove screw that holds cable clamp and release wiring harness from cooler.

Screw tightening.

Torque: **9Nm.**

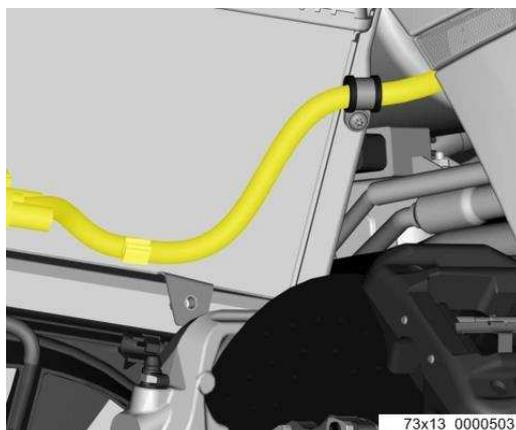

Open 2 cable clamps and extract 2 cooling pipes.

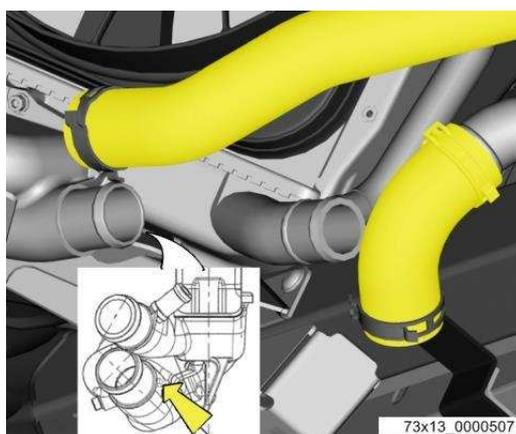

Remark.

During reassembly align marks respectively present on radiator and pipe, to install component as it was in origin. **If any marks are present**, use a **marker pen** to sign them before disassembly.



Remark.

Replace at each reassembly **cable clamps**

Open 2 cable clamps of coolant lines still connected to cooler and extract two pipes..

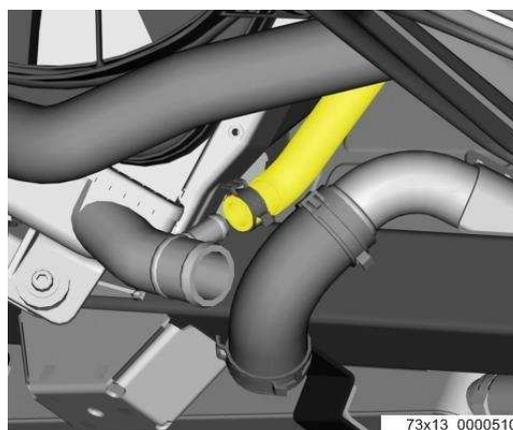

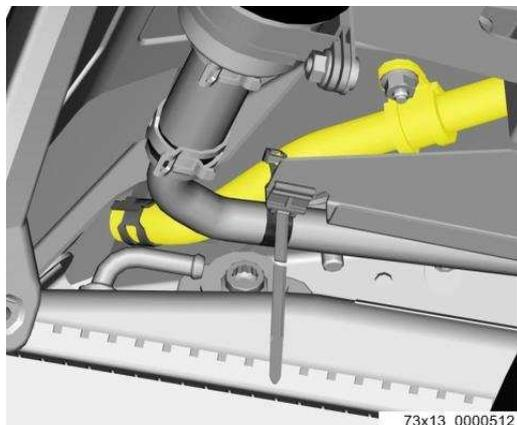

Remove screw that fixes hose clamp and then extract hose from cooler.

Screw tightening.

Torque: **10Nm**.

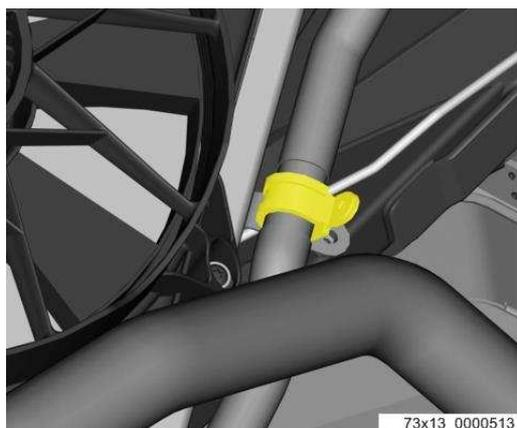

Remove 4 screws that hold left cooler group, free it from chassis then extract it from vehicle.

Screw tightening.

Torque: **20Nm**

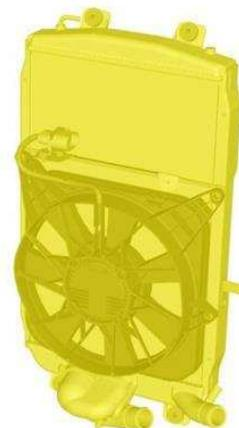

Left radiator group which includes fan, clamp brackets, washers, spacers and buffers has been just removed, it is now necessary to disassembly in order to replace cooler.



12. Disassembly of left radiator assembly and cooler replacement.



Remark.

Operation to be performed on bench

Remove 2 screws that holds clamp mount and free cooler mount.

Screw tightening.

Torque: **10Nm.**



73x13_0000519

Release wiring harness plug of electric radiator fan from mount, remove 4 screws and then separate radiator fan from left cooler

Screw tightening.

Torque: **10Nm.**

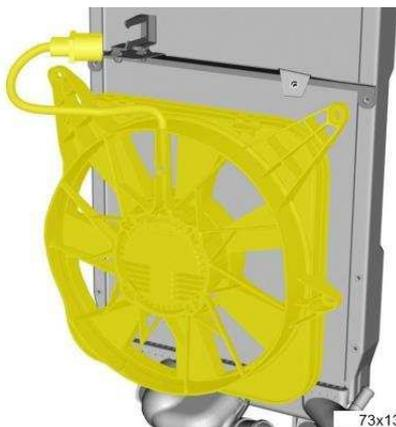

73x13_0000523

Remove bracket that bears wiring harness

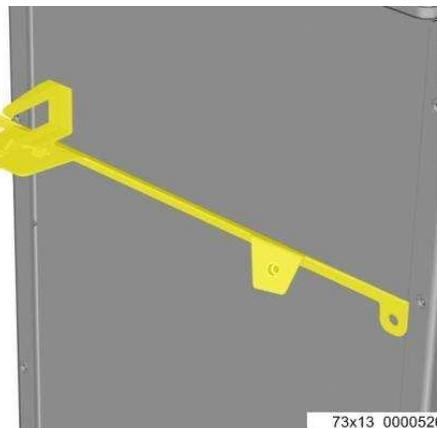

73x13_0000526

Remove washer, buffers, spacers and brackets which fix cooler to chassis.

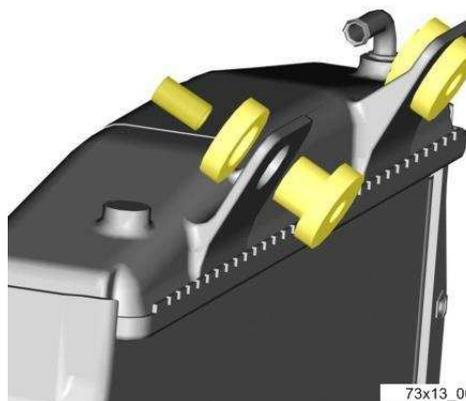

73x13_0000527

Now replace cooler.

13. Air duct disassembly.

Remove 4 screws and take component off.

Screw tightening.

Torque: **9Nm**



Replace air duct .

14. Reassembly components in reverse order.

Right side

15. Disassembly of right air conveyor grille.

Unfasten grill from interlocking joint and remove it from vehicle.

16. Disassembly of engine control unit (LIE) bracket..

Unscrew 2 nuts and remove bracket that holds control unit mount.

Release ecu from rear mount and lean it on suspension arm..

Nut tightening.

Torque: **9Nm**.



Remark.

Be extremely careful **to not disconnect** electronic control unit plug and not damage it.

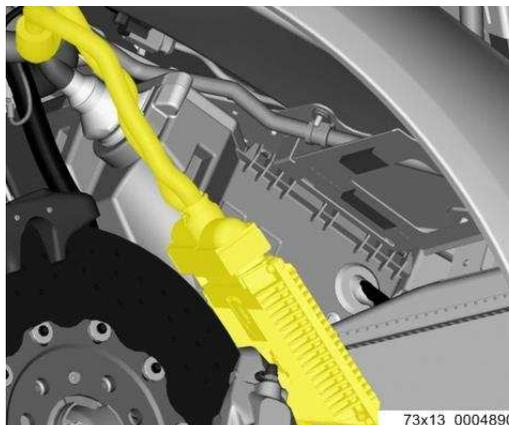

17. Disassembly of right radiator assembly.

Disconnect plug of electric radiator fan, remove screw that holds cable clamp and release wiring harness from cooler.

Screw tightening.

Torque: **9Nm**.

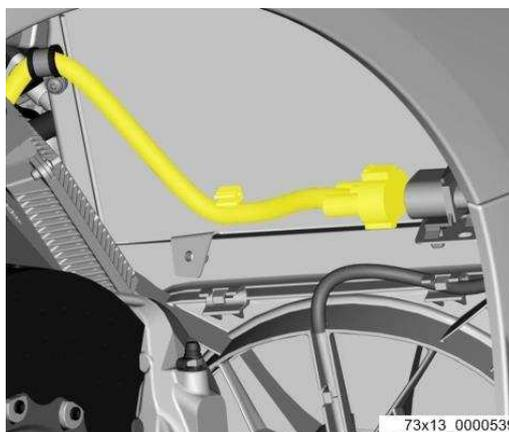

Open clamp that holds coolant line and then extract pipe.

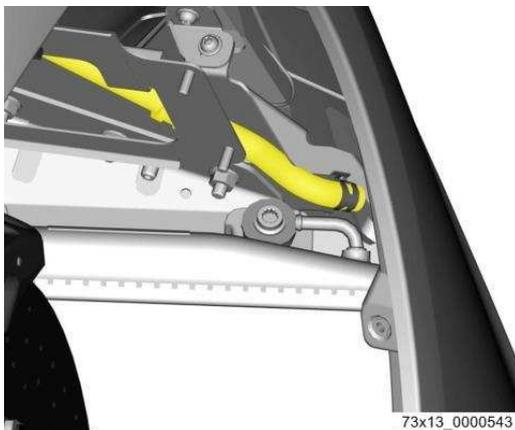

Open 2 cable clamps that holds coolant lines which are still connected then extract 2 pipes.

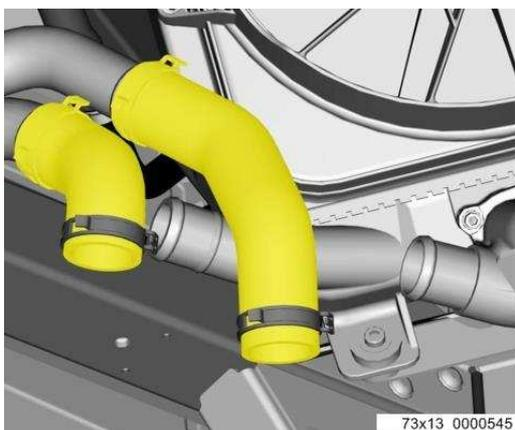

Remark.

During reassembly align marks respectively present on radiator and pipe, to install component as it was in origin. **If any marks are present, use a marker pen to sign them before disassembly.**



Remark.

Replace at each reassembly **cable clamps**

Remove 4 screws that hold right radiator group, free it from chassis without removing it from car.

Screw tightening.

Torque: **20Nm**

Getting access to radiator group from air intake on right side, remove 2 screws that secure A/C hose then disconnect it from condenser.

Screw tightening.

Torque: **9Nm**

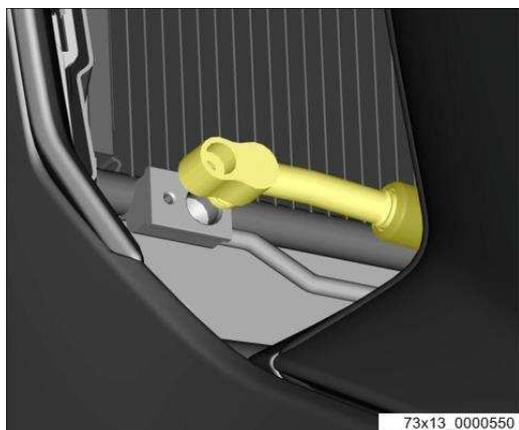

Now remove right radiator assembly that includes electric fan, cable clamp bracket, washers, spacers, buffers and condenser; now it is necessary to disassembly in to parts to replace cooler.



73x13_0000517

18. Disassembly of left radiator assembly.



Remark.

Operation to be performed on bench.

Disconnect wiring harness plug and remove 4 screws and separate electric fan from radiator assembly, then remove bracket plug.

Screw tightening.

Torque: **10 Nm**

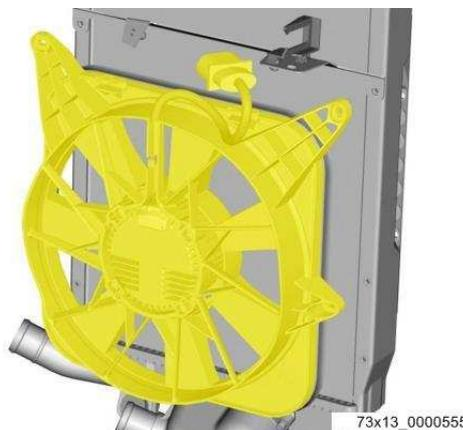

Remove 4 screws that hold condenser and separate it from radiator assembly.

Screw tightening.

Torque: **5 Nm.**

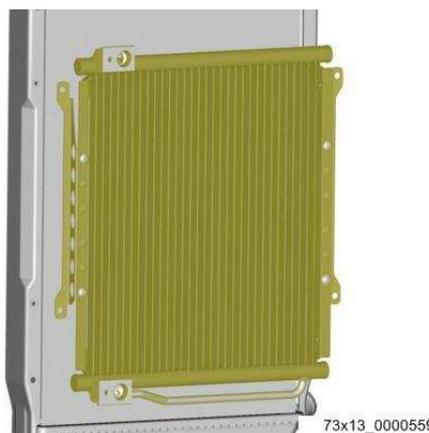

73x13_0000559

Remove washer, spacers, buffers and brackets which fix radiator onto chassis.

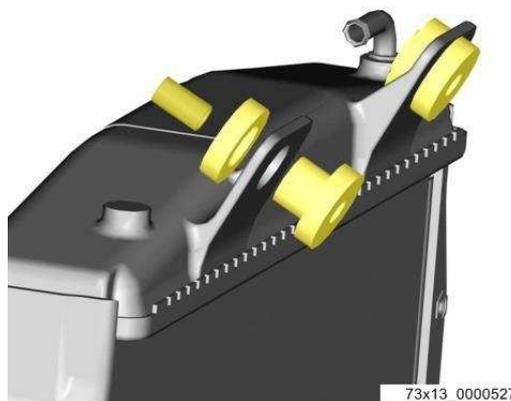

73x13_0000527



Replace cooler.

19. Air duct disassembly .

To remove easily left duct, release from chassis and remove a part of air conditioning hose.



Disconnect plug of pressure switch.

Release cable clamp that fix it to chassis.

At last remove screw that fix hose and then take it off.

Screw tightening.
Torque: **9Nm**

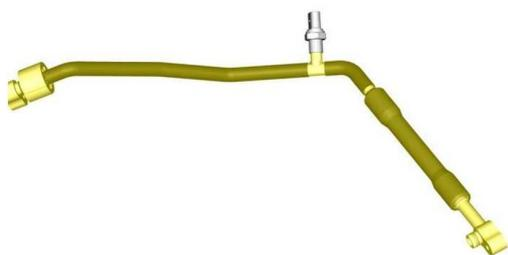

73x13_0003509

Remove 4 screws that hold duct and separate it from vehicle.

Screw tightening.
Torque: **9Nm**



Replace air duct .

20. Reassembly parts in reverse order on right side.

Your Area Manager is at full disposal for further information.

Best regards

Customer Service