

L83X-
A.03.14

To: Official After Sales Network
Subject: Cross member bolts.
Date: 14th/03/2014
Pages: 4



Subject

Cross member bolts.

Model

All Lamborghini Aventador Coupè & Roadster LP700 Model Year **12,13** and **14** From VIN **CLA00091** to **ELA02427**.

Warning: some vehicles included in this VIN range may not be involved, so check carefully on the Lamborghini WEB Portal (at the section named VIN Info) if the cars in your workshop or in your dealer stock are involved before performing any other operation.

Information to the field

As a result of continuous product monitoring, Automobili Lamborghini Spa has found that on some vehicles, the bolts which secure the engine cross member may get loosen and consequently cause noise.

Field solution

Replace the bolts as prescribed in the following instruction.

P/N	Description	Q
0R8340099	Cross member bolts Kit - M8X22 bolt (pink thread locker) Q 2. - M8X25bolt (green thread locker) Q 2.	1

Warranty Claim data

The warranty reimbursement request for this re-work action will be managed by the following standard Warranty Claim procedures.

Campaign Code: L83X-A.03.14
Campaign Des.: Cross member bolts.
Cost code: 50
Component code: CCA0314
Trouble code: 220
Labor code: CCA0314100
Labor Time: 0.65 h

Remember to fill all data in the section “Service and Recall Campaign” in the Warranty booklet of the vehicle as shown below.

Necessary material

- T45 standard torx wrench.
- Ratchet wrench.
- 13 mm socket.
- 27 Nm torque wrench,

Working area Identification

1. Locate working area: engine bay.
2. Identify bolts to be replaced with new ones.

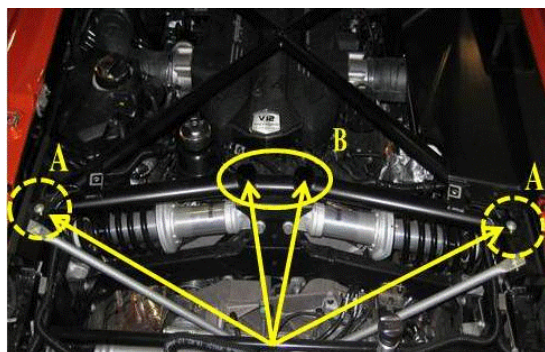

A. At the sides:

- Bolt to be replaced (X2)

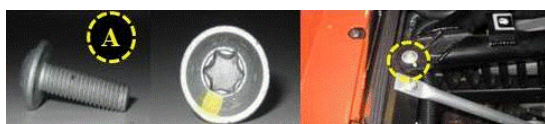

Rev.01

The information and procedures published below are strictly confidential and intended exclusively for authorized operators and individuals. All copyrights are the property of Automobili Lamborghini S.p.A based on copyright law. The company reserves the right to make updates and modifications. The reprinting, reproduction, forwarding to unauthorized people and/or to third parties and partial or entire translation thereof are prohibited without written authorization from Automobili Lamborghini S.p.A.

doc. nr: L/V6_M06 Rev.[02]

1/4



- New type (X2).



GREEN thread locker.

B. In the middle:

- To be replaced (X2).

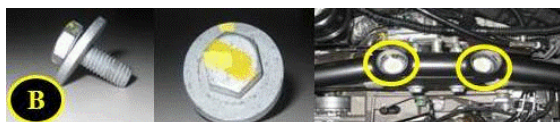

- New type (X2).



PINK thread locker.

Instructions.



WARNING.



Operation to be performed at cold engine!

3. Fit protections onto coachwork to avoid accidental damages

4. Unscrews 2 screws of .engine bay rear es-
thetical cover.

Screws tightening.
Pressure torque: **6 Nm.**



5. Remove 8 screws that secure rear es-
thetical cover in engine bay.





6. Remove 2 Buffers.

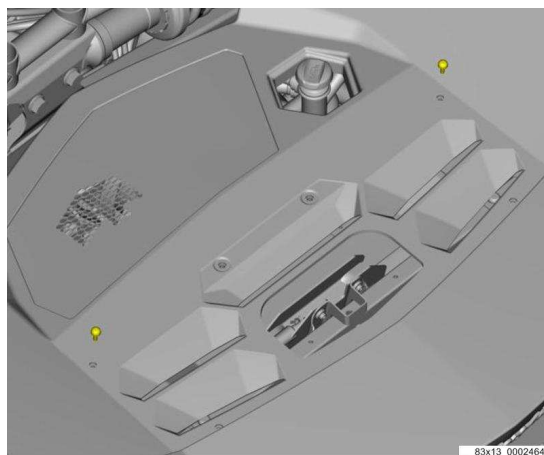

7. Remove esthetical cover.

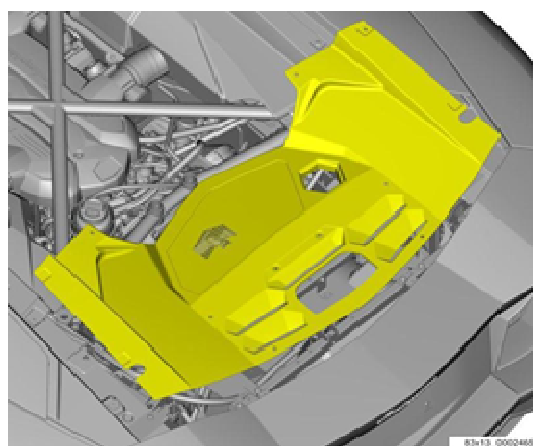

Screw replacement.



Caution.

This instruction refers to both sides, left and rear.

8. Unscrew and replace engine cross member side bolts with new green coloured thread-locker ones (p/n N0195306).

Bolt tightening.

Pressure torque: **27 Nm ± 10%**.

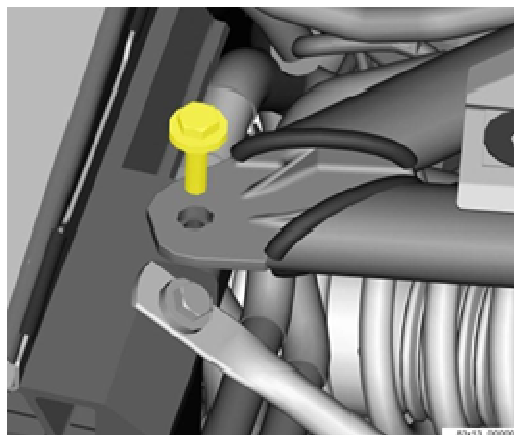

9. Replace 2 central bolts with pink threadlocker ones.

Bolt tightening.

Pressure torque: **27 Nm ± 10%**.

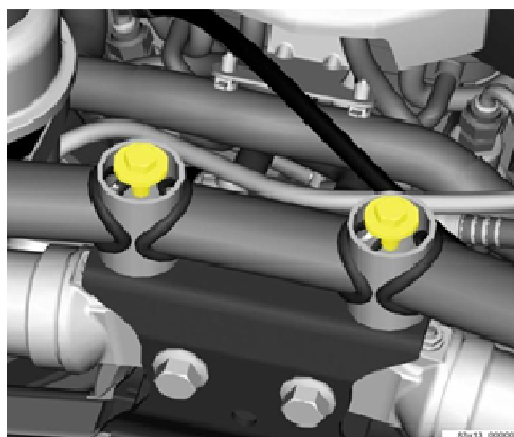

L83X-
A.03.14

To: Official After Sales Network
Subject: Cross member bolts.
Date: 14th/03/2014
Pages 4



10. Re-assembly esthetical rear engine cover following the instruction in reverse order.

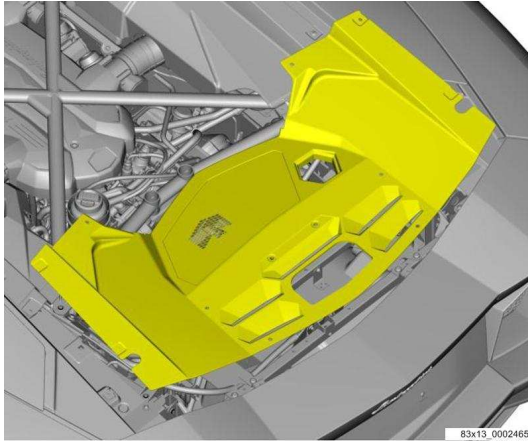

Rev.01

The information and procedures published below are strictly confidential and intended exclusively for authorized operators and individuals. All copyrights are the property of Automobili Lamborghini S.p.A based on copyright law. The company reserves the right to make updates and modifications. The reprinting, reproduction, forwarding to unauthorized people and/or to third parties and partial or entire translation thereof are prohibited without written authorization from Automobili Lamborghini S.p.A.

doc. nr: L/V6_M06 Rev.[02]

4/4