

L735-A.01.15	To:	Official After Sales Network	
	Subject:	Headliner bonding	
	Date	4/17th/2015	
	Pages	5	

Subject

Headliner bonding

Model

All Lamborghini Model Aventador Roadster all versions MY 2013, 2014 and 2015 from VIN **DLA00510** until VIN **FLA03345**

Warning: some vehicles included in this VIN range may not be involved, so check carefully on the Lamborghini WEB Portal (at the section named VIN Info) if the cars in your workshop or in your dealer stock are involved before performing any other operation.

Information to the field

As a result of continuous product monitoring, Automobili Lamborghini S.p.A. has found that on some cars exposed to extreme environmental conditions, the bonding spot of headliners to the panels which compose the hard top may get weak and noisy.

Field solution

Headliner bonding

Parti di ricambio

Cod*.	Desc. codice	Q
n/a	n/a	n/a

Replaced parts management.

Not required.

Warranty Claim data

The warranty reimbursement request for this rework action will be managed by the following standard Warranty Claim procedures.

Campaign Code: L735-A.01.15
Campaign Description: Headliner bonding
Cost ode: 55
Component code: CCA0115
Trouble code: 220
Labour Code: CCA0115
Labour time: 2,5 h

Remember to fill all data in the section “Service and Recall Campaign” in the Warranty booklet of the vehicle as shown below.

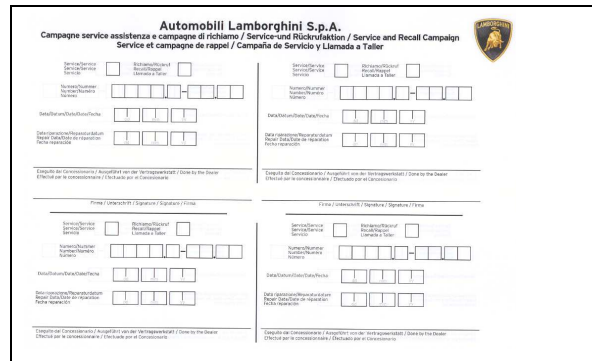

Necessary material

All the materials listed below are available commercially in your market. If you find difficulty in finding them ask your Service Area Manager for assistance. The campaign labor time is increased as a means to arrange this cost locally.

1. 3M™ Dual Lock™ Reclosable Fastener SJ3550.	
2. Henkel TEROMIX-6700 (also known as TEROSON PU 6700)	
3. Isopropyl alcohol (IPA).	
4. Primer: 3M™ Automotive Adhesion Promoter-Sponge Applicator 4298.	

Rev.02	The information and procedures published below are strictly confidential and intended exclusively for authorized operators and individuals. All copyrights are the property of Automobili Lamborghini S.p.A based on copyright law. The company reserves the right to make updates and modifications. The reprinting, reproduction, forwarding to unauthorized people and/or to third parties and partial or entire translation thereof are prohibited without written authorization from Automobili Lamborghini S.p.A.	1/5
	doc. nr: L/V6_M06 Rev.[02]	

L735-
A.01.15

To: Official After Sales Network
Subject: Headliner bonding
Date: 4/17th/2015
Pages: 5



Repair Method

1. Primaries

The hardtop is composed by two panels, left and right following called “panel” in short.

This instructions details the rework of a single panel one at a time.

Fold with foam or other soft material your working bench to keep panels safe from scratches or dents once they have been laid upon it.

Cut **16** dual lock adhesive pieces sized **25mm long** and **19mm wide** each.



Remark!

- Headliner is attached to each panel in **8** spot with **3M Dual Lock SJ3550** (Velcro type): general purpose acrylic adhesive on the back of a black reclosable fastener.
- Fasteners (**3M Dual Lock SJ3550**) are bonded to one half of hard top and headliner by acrylic adhesive while the black fasteners keep both parts attached.

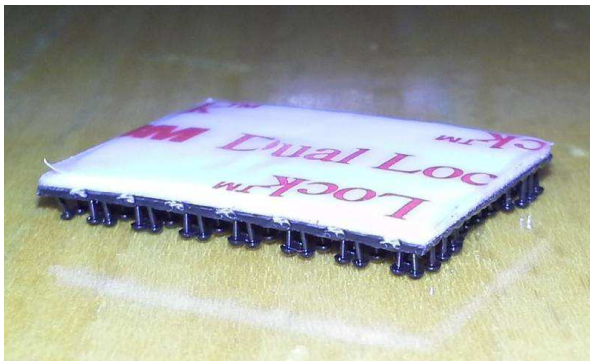

2. Dual lock inspection

Lay panels over your folded bench one at a time.

Separate headliner from panel.

If Dual Lock present on both appears in good status and well attached skip at the step nr 7.

3. Removal of old Dual Lock Reclosable Fastener.

Dual Locks on panel can be replaced relatively easily.

Remove any white acrylic foam left on panel with a fingernail or a very blunt plastic scraper.



If necessary remove coupling dual lock on headliner.



4. Cleaning of bonding Surfaces on hard top.

Operation to be performed storing hard top and cleaning agent (isopropyl alcohol) for at least 1 hour at **20-27 °C**.

Rub 8 bonding surfaces, positioning tabs and their inner perimeters with a cloth soaked with **50:50 solution of isopropyl alcohol (IPA) and water** (previously prepared).

Wipe off the remaining solvent with a clean cloth and let them cleaned surface dry.

Rev.02

The information and procedures published below are strictly confidential and intended exclusively for authorized operators and individuals. All copyrights are the property of Automobili Lamborghini S.p.A based on copyright law. The company reserves the right to make updates and modifications. The reprinting, reproduction, forwarding to unauthorized people and/or to third parties and partial or entire translation thereof are prohibited without written authorization from Automobili Lamborghini S.p.A.

doc. nr: L/V6_M06 Rev.[02]

2/5

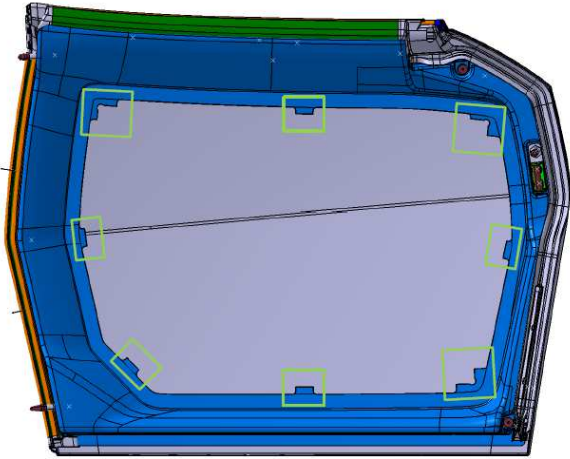

5. Primer application on bonding Surfaces.

To ensure a strong bond for the Dual Lock attachment, panel contact surfaces are to be primed with **3M 4298 Adhesion Promoter**. Make sure all cleaning solvent has dried from the Panels surface before application.



Apply a uniform layer of primer on the bonding surfaces.

Allow to dry at least 3 minutes or until completely dry.



Remark!

The primer will stain panel, so If it unintentionally gets on visible surfaces, clean them with the cleaning solvent used at the former step.

6. Dual Locks application panel.

Bond Dual Lock pieces within 1 hours from primer application on panel.

Remove the backing liner from Dual Lock pieces and, without touching the bonding surfaces, press each pieces to a corresponding mating surface on panel, leaving a small gap, approximately of **1,8 mm**; from positioning tabs.





With a rolling motion of the finger, press each Dual Lock firmly to the Panel.

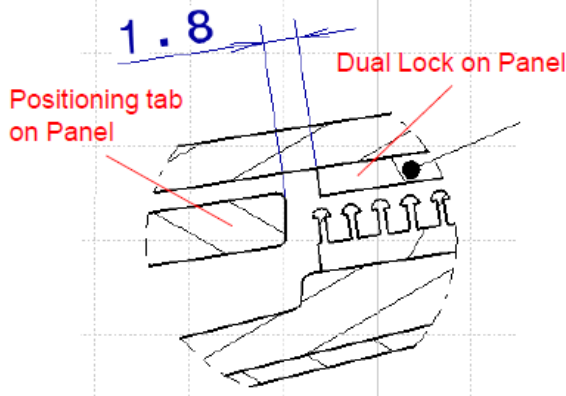
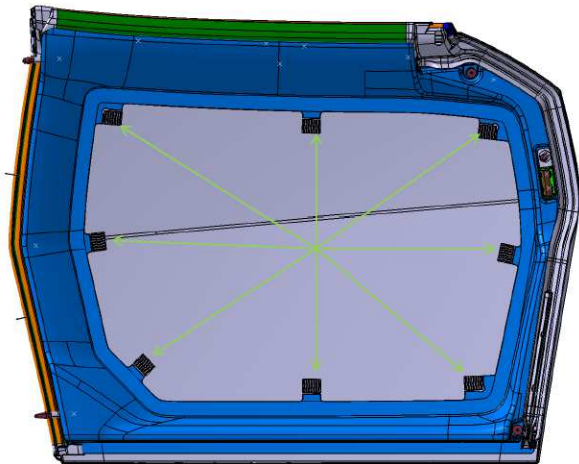

Before going on with the next step **let dual lock adhesive cure for 24 hours** (to achieve the maximum bonding strength are necessary 72 h).

7. Adhesive application for Very Hot Climates; **Henkel Teromix-6700.**



Prior to Teromix-6700 application it is necessary to read:

- the Safety Data Sheet for information about precautionary measures and safety recommendations. Also, for chemical products exempt from compulsory labelling, the relevant precautions should always be observed.

- The instruction sheet for correct application procedure.
- Dual lock must have been cured for **24 hours** if replaced.

Teromix-6700 is a polyurethane-based two-component adhesive which cures at room temperature.

Apply adhesive to eight positions next to the Dual Lock pieces on panel positioning tabs, to make sure the adhesive will not be visible.

The bead of the adhesive must be at least **5mm high**, to ensure contact to the Headliner.



Remark!

Once headliner has been bonded to the panel, it is not possible to remove it without damages to both items.

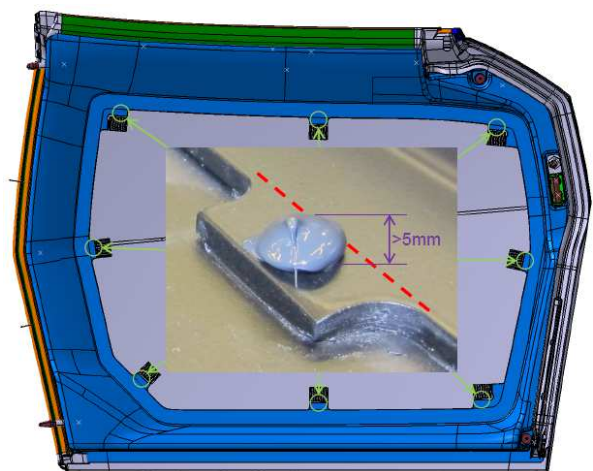

8. Headliner mating to panel



Remark!

- Operation to be performed on a soft surface to avoid damages.
- Use special care in mating parts because it will be no longer possible separate them after Teromix has been cured.

L735- A.01.15	To: Official After Sales Network Subject: Headliner bonding Date: 4/17th/2015 Pages: 5	
--------------------------	--	---

Match dual lock present on headliner with the one present on panel to guarantee the perfect mating

Let adhesive cure for **6 hours**, at room temperature to reach 85% of its final strength.



Rev.02	<p>The information and procedures published below are strictly confidential and intended exclusively for authorized operators and individuals. All copyrights are the property of Automobili Lamborghini S.p.A based on copyright law. The company reserves the right to make updates and modifications. The reprinting, reproduction, forwarding to unauthorized people and/or to third parties and partial or entire translation thereof are prohibited without written authorization from Automobili Lamborghini S.p.A.</p> <p style="text-align: right;">doc. nr: L/V6_M06 Rev.[02]</p>	5/5
--------	---	-----