

L624-
A.03.16

To: Official After Sales Network
Subject: Cowl cover update
Date: March 18, 2016
Pages: 3



Subject.
Cowl cover update .

Model.
Huracàn Coupè

Model year.
2015 .

Special or Limited Versions.
Right hand Drive vehicles.

Markets.
All where RHD cars are present.

VIN identification
 From **FLA00163** to **FLA03641**.

Warning: some vehicles included in this VIN range may not be involved, so check carefully on the Lamborghini WEB Portal (at the section named VIN Info) if the cars in your workshop or in your dealer stock are involved before performing any other operation.

Information to the field.
 As a result of continuous product monitoring, Automobili Lamborghini Spa has found that the cowl cover of some RHD cars is missing of the panel which aims to protect the pump of the Lifting system from humidity.

Field solution.
 Update the car following the herein reported instructions.

Spare parts.

P/N	Description	Q
4T2698010	Lifting pump cover Kit. It includes: - 1 Cover; - 1 Screw.	1

Replaced parts management.

Store properly and tagged the parts replaced with bar code form for their identification during Area Manager visits.

Warranty Claim data.

The warranty reimbursement request for this rework action will be managed by the following standard Warranty Claim procedures.

Campaign Code: L624-A.03.16
Campaign Des.: Cowl cover update
Cost code: 50
Component code: CCA0316
Trouble code: 220
Labor code: CCA0316100

Labor Time: 2 h

Remember to fill all data in the section “Service and Recall Campaign” in the Warranty booklet of the vehicle as shown below.

Necessary tools/material.

P/N	Description	Q
-	Drilling Machine	1
-	<u>8mm drill bit</u>	1

Rev.01

The information and procedures published below are strictly confidential and intended exclusively for authorized operators and individuals. All copyrights are the property of Automobili Lamborghini S.p.A based on copyright law. The company reserves the right to make updates and modifications. The reprinting, reproduction, forwarding to unauthorized people and/or to third parties and partial or entire translation thereof are prohibited without written authorization from Automobili Lamborghini S.p.A.

doc. nr: L/V6_M06 Rev.[02]

1/3



Preliminary operations:



Warning!



- a) Operation to be performed at cold engine.
 - b) Wear protective outfits such us mask, goggle ...etc
1. Secure the vehicle by engaging the parking brake.
 2. Luggage compartment disassembling.

Disassemble the luggage compartment following the instructions reported at the Chapter 08, paragraph 63 from the workshop manual related to the subject vehicle's market.

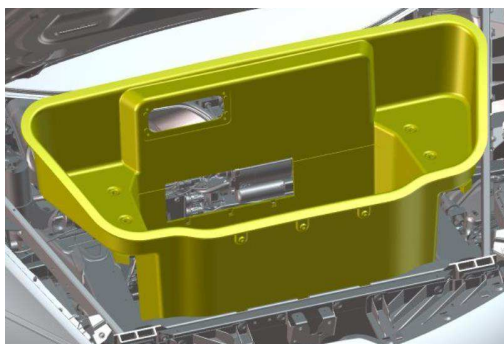

3. Compressor fastener removal.

Remove the compressor screw which is present over the unit's right side close to the intake filter.



Notes for the reassembly.

Screw tightening;
torque: **30Nm**



Cover installation:



Warning.

To assemble the cover it is necessary to perforate the cowl cover using a drilling machine equipped with the 8mm drill bit.

4. Working area identification.

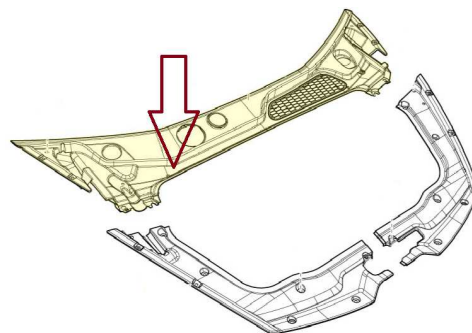

5. Drill point marking.

Use a gauge and a marker to sign the point to be drilled as shown in the figure, observing the following measures:

- Distance from the cowl edge: **28mm**
- Distance from the water drain hole: **50mm**

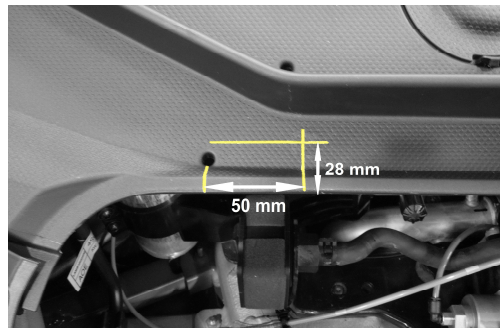
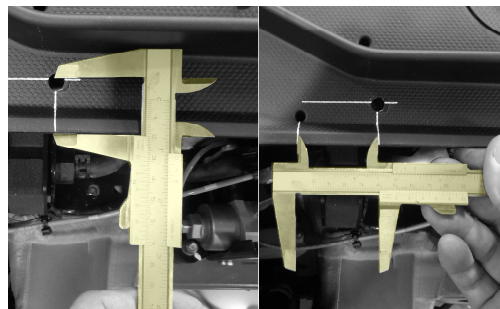



6. Cowl cover drilling.

Make a hole (\varnothing 8mm) by a drilling machine with the appropriate drill bit in the previously marked point, and clean the working area from residual marker traces.

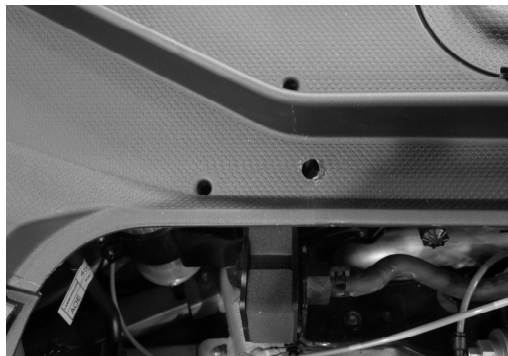

7. Install the cover and place the Lifting System conduit as shown in the figure.

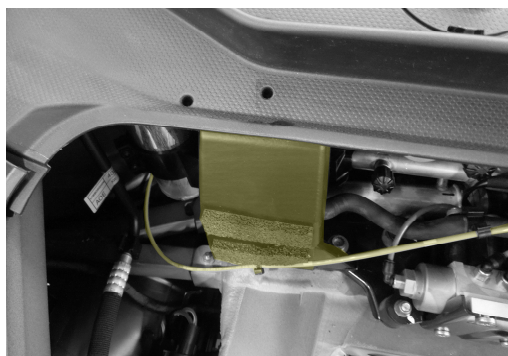

8. Fix the cover to the cowl cover with the screw provided in the kit.

Screw tightening;
Torque: **2,5Nm**



Warning

Complete the cover and compressor fastening with the screw removed at point 3.

9. Final steps.

After having installed, the cover restore the vehicle performing the preliminary operations in reverse order.