

Brake Booster Vacuum Check Valve Rattle/Buzz Noise

Service Category Brake

Section Brake System

Market USA

Lexus Supports
ASE Certification 

Applicability

YEAR(S)	MODEL(S)	ADDITIONAL INFORMATION
2004 – 2010	RX330, RX350	

Introduction

Some RX 330/350 vehicles may exhibit a rattle or buzz type noise coming from the driver's side instrument panel area. The noise can be duplicated when lightly accelerating and then decelerating, or when depressing the brake pedal with the shift lever in Park and then releasing the brake pedal. An improved vacuum check valve is now available to reduce this noise.

Parts Information

VALVE SHAPE	PREVIOUS PART NUMBER	CURRENT PART NUMBER	PART NAME	QTY
Straight Valve	44730-22150	44730-20080	Vacuum Valve Assembly	1
90 Degree Valve	44730-12070	44730-14050		1

Warranty Information

OP CODE	DESCRIPTION	TIME	OFF	T1	T2
BR9004	R & R Brake Booster Vacuum Check Valve	0.4	44730-#2##0	91	99

APPLICABLE WARRANTY

- This repair is covered under the Lexus Comprehensive Warranty. This warranty is in effect for 48 months or 50,000 miles, whichever occurs first, from the vehicle's in-service date.
- Warranty application is limited to correction of a problem based upon a customer's specific complaint.

Brake Booster Vacuum Check Valve Rattle/Buzz Noise

Repair Procedure

1. Confirm the noise is coming from the brake booster vacuum check valve.

NOTE

Replace vacuum check valve with the same type as originally equipped (straight or 90°).

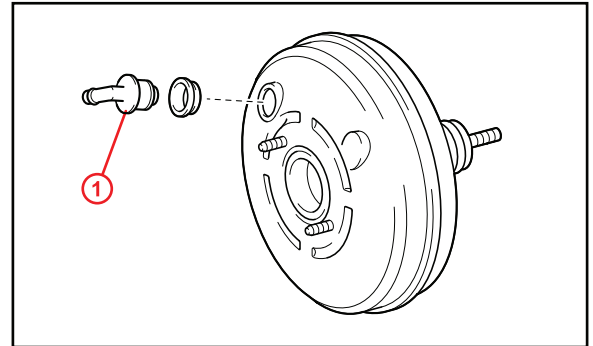
Figure 1.**1** Vacuum Check Valve

2. Remove the vacuum tube clip from the brake booster check valve.
3. Remove and replace the brake booster vacuum check valve.

NOTE

Make sure **NEW** valve is fully seated into brake booster grommet and returned to original condition.

4. Reconnect vacuum hose to the brake booster check valve and secure with clip.
5. Confirm that there are no vacuum leaks.
6. Confirm the noise has been eliminated.