



Technical Service BULLETIN

October 27, 2007

Title:

M.I.L. "ON" DTC P0171, P030#, AND/OR P0133 ENGINE RUNNING LEAN IN SUBFREEZING AMBIENT TEMPERATURES

Models:

'03 - '08 Corolla & Matrix (1ZZ-FE)

ENGINE
EG045-07

Introduction Following a cold soak in subfreezing ambient temperatures, some 2003 - 2008 model year Corolla and Matrix vehicles equipped with a 1ZZ-FE engine may exhibit a M.I.L. "ON" with one or more of the following Diagnostic Trouble Codes (DTCs) as the result of a vacuum leak at the intake manifold.

- P0171 - System Too Lean (Bank 1)
- P0300 - Random Multiple Cylinder Misfire Detected
- P030# - Cylinder (1-4) Misfire Detected
- P0133 - Oxygen Sensor Slow Response (Bank 1 Sensor 1)

Please use the following procedure to repair the vehicle.

- Applicable Vehicles**
- **2003 - 2008** model year **Corolla** and **Matrix** vehicles equipped with the **1ZZ-FE engine**.

Parts Information

| PREVIOUS PART NUMBER | CURRENT PART NUMBER | PART NAME | QTY |
|----------------------------|---------------------|--|-----|
| 17171-22030 17171-0D020 | 17171-22060 | Gasket, Intake Manifold to Head, No. 1 | 1 |

Warranty Information

| OP CODE | DESCRIPTION | TIME | OFF | T1 | T2 |
|---------|------------------------------|------|----------------------------|----|----|
| 170051 | R & R Intake Manifold Gasket | 1.0 | 17171-22030 17171-0D020 | 04 | 13 |

Applicable Warranty*:

- This repair is covered under the Toyota Federal Emission Warranty. This warranty is in effect for 36 months or 36,000 miles, whichever occurs first, from the vehicle's in-service date.**
- For California specification vehicles sold, registered, and operated in California, Maine (starting with 2004 model year), Massachusetts, and Vermont, this repair is covered under the California Emission Warranty, which is in effect 36 months or 50,000 miles, whichever occurs first, from the vehicle's in-service date.

* Warranty application is limited to correction of a problem based upon a customer's specific complaint.
 ** Due to a misprint in the *Owner's Warranty Information* booklets, the Warranty Department will honor claims under the 60 months or 60,000 mile Powertrain Warranty for 2000 - 2004 model year vehicles.



**Required
Tools &
Equipment**

| REQUIRED EQUIPMENT | SUPPLIER | PART NUMBER | QTY |
|--|----------|-------------|-----|
| TIS techstream* NOTE: Software version 2.20.015 or later is required.  | ADE | TSUNT | 1 |

* Essential SST.

NOTE:

- Additional techstream units may be ordered by calling Approved Dealer Equipment (ADE) at 1-800-368-6787.
- The Toyota Diagnostic Tester and CAN Interface Module may also be used to perform the service procedures listed in this bulletin.

**Inspection
Procedure****NOTE:**

The vehicle **MUST** be diagnosed following a cold soak. If the vehicle is at operating temperature, the condition will **NOT** be present.

1. Monitor the following Data List parameter: Short FT #1 (Short Term Fuel Trim for Bank 1).

Using TIS techstream, select:

Connect to Vehicle/Engine and ECT/Data List/Short FT #1.

2. Following conventional diagnostic procedure, confirm if there is a leak where the intake manifold and cylinder head meet between each intake runner.

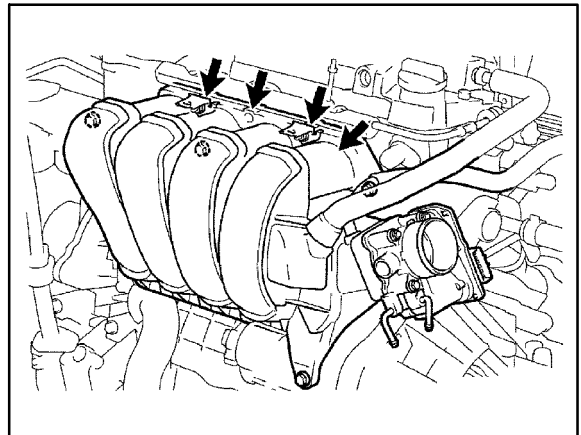

3. Did the short term fuel trim change to a rich reading (negative fuel trim) in step 2?
 - If **YES** — Replace the intake manifold gasket.
 - If **NO** — Check for other vacuum leaks or lean running conditions per the Technical Information System (TIS).

Repair Procedure

1. Drain the engine coolant.

Refer to TIS:

- 2003 or 2004 model year Corolla Repair Manual, *Engine/Hybrid System - Cooling - "Coolant: Replacement"*
- 2005 model year Corolla Repair Manual, *Engine/Hybrid System - Cooling - "Engine Coolant (1ZZ-FE): Replacement"*
- 2006, 2007, or 2008 model year Corolla Repair Manual, *Engine/Hybrid System - Cooling - "1ZZ-FE Cooling: Coolant: On-Vehicle Inspection"*

2. Remove the air cleaner hose No. 1.

- A. Disconnect the VSV connector.
- B. Remove the clamp of the engine wire.
- C. Disconnect the fuel vapor feed hose No. 1 from the VSV.
- D. Disconnect the fuel vapor feed hose No. 3 from the VSV.

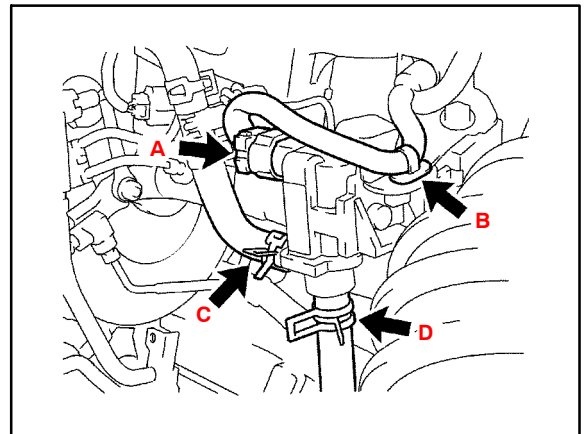

- E. Loosen the 2 hose clamp bolts, then remove the air cleaner hose No. 1.

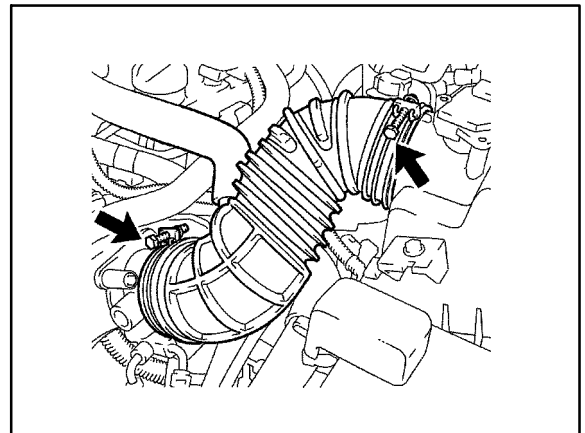

3. Remove the intake manifold.

- A. Remove the 2 clamps of the engine wire from the clamp bracket.

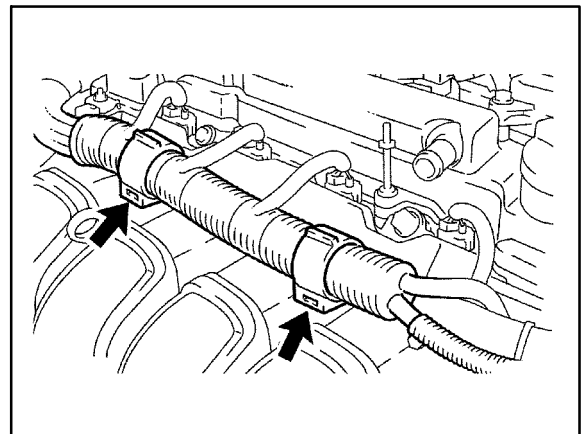

**Repair
Procedure**
(Continued)

- B. Disconnect the throttle control motor connector or accelerator cable (if equipped).

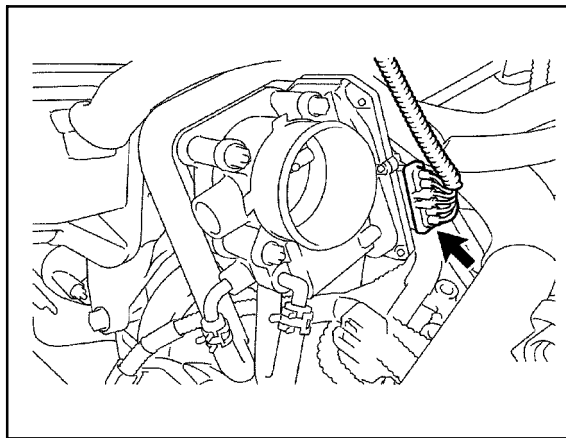

- C. Disconnect the water bypass hose from the throttle body.
D. Disconnect the water bypass hose No. 2 from the throttle body.

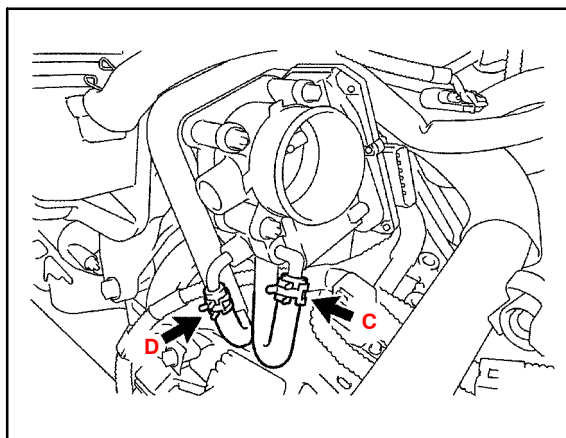

- E. Disconnect the union to check valve hose from the intake manifold.

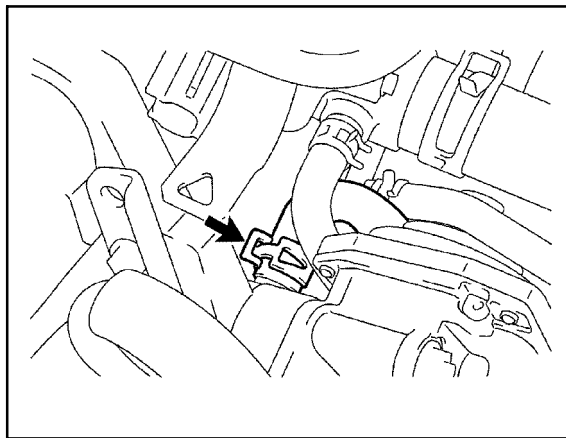

**Repair
Procedure**
(Continued)

- F. Remove the 4 bolts, 2 nuts, and 2 clamp brackets.
- G. Remove the intake manifold and throttle body.
- H. Remove the gasket from the intake manifold.

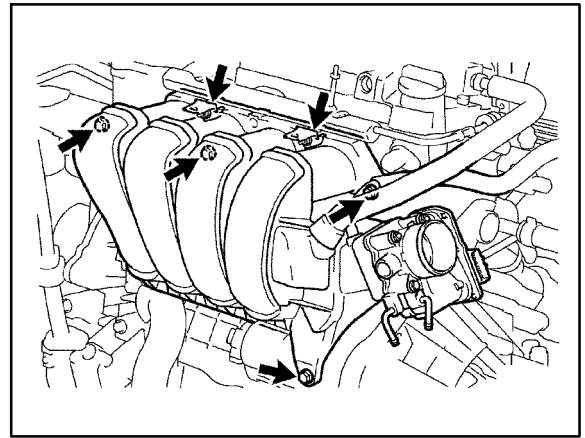

4. Clean the mounting surface of the intake manifold.
5. Install the intake manifold.
 - A. Install a NEW gasket onto the intake manifold.
 - B. Install the intake manifold and throttle body assembly with the 2 brackets, 4 bolts, and 2 nuts. Uniformly tighten the bolts and nuts in several passes.
Torque: 30 N•m (306 kgf•cm, 22 ft•lbf)
 - C. Connect the union to check valve hose to the intake manifold.
 - D. Connect the water bypass hose No. 2 to the throttle body.
 - E. Connect the water bypass hose to the throttle body.
 - F. Connect the throttle control motor connector.
 - G. Install the 2 clamps of the engine wire onto the clamp bracket.
6. Reinstall the air cleaner hose No. 1.
 - A. Install the air cleaner hose No. 1 with the 2 hose clamp bolts.
 - B. Connect the fuel vapor feed hose No. 3 to the VSV.
 - C. Connect the fuel vapor feed hose No. 1 to the VSV.
 - D. Install the clamp of the engine wire.
 - E. Connect the VSV connector.
7. Fill and check the engine coolant.
Refer to TIS:
 - 2003 or 2004 model year Corolla Repair Manual, *Engine/Hybrid System - Cooling - "Coolant: Replacement"*
 - 2005 model year Corolla Repair Manual, *Engine/Hybrid System - Cooling - "Engine Coolant (1ZZ-FE): Replacement"*
 - 2006 or 2007 or 2008 model year Corolla Repair Manual, *Engine/Hybrid System - Cooling - "1ZZ-FE Cooling: Coolant: On-Vehicle Inspection"*
8. Clear the fuel trim values by disconnecting the negative (-) battery cable for 90 seconds.
9. Test drive the vehicle and confirm normal operation.