

September 18, 2015

02365 Version 1

Security System Sounds or May Not Set

AFFECTED VEHICLES

Year	Model	Trim	VIN Range
2014–15	MDX	ALL	ALL
2016	MDX	ALL 2WD	5FRYD3H..GB000001 to 5FRYD3H..GB007326
2016	MDX	ALL SH-AWD	5FRYD4H..GB000001 to 5FRYD4H..GB029373

SYMPTOM

The factory security system may sound on its own or the system may not set. The client may also notice that the horn does not sound or the lights do not flash when setting the alarm (security system is not set).

POSSIBLE CAUSES

Excessive clearance in the hood latch causes the hood latch switch to indicate the hood is open when it is not.

CORRECTIVE ACTION

Replace the hood latch assembly.

PARTS INFORMATION

Part Name	Part Number	Quantity
Hood Latch Assembly	74120-TZ5-A01	1

WARRANTY CLAIM INFORMATION

The normal warranty applies.

Operation Number	Description	Flat Rate Time	Template ID	Failed Part Number
8121E5	Replace hood latch assembly. (includes HDS diagnosis)	0.4 hr	15-046N	74120-TZ5-A01

Defect Code: 03214

Symptom Code: 03217

Skill Level: Repair Technician

CLIENT INFORMATION: The information in this bulletin is intended for use only by skilled technicians who have the proper tools, equipment, and training to correctly and safely maintain your vehicle. These procedures should not be attempted by “do-it-yourselfers,” and you should not assume this bulletin applies to your vehicle, or that your vehicle has the condition described. To determine whether this information applies, contact an authorized Acura automobile dealer.

DIAGNOSIS

1. If the client complaint is alarm goes off by itself, check the security system history data using the HDS. If the **Alarm Device** shows **Security Hood Switch**, go to REPAIR PROCEDURE. If the history data does not show **Security Hood Switch**, this bulletin does not apply.

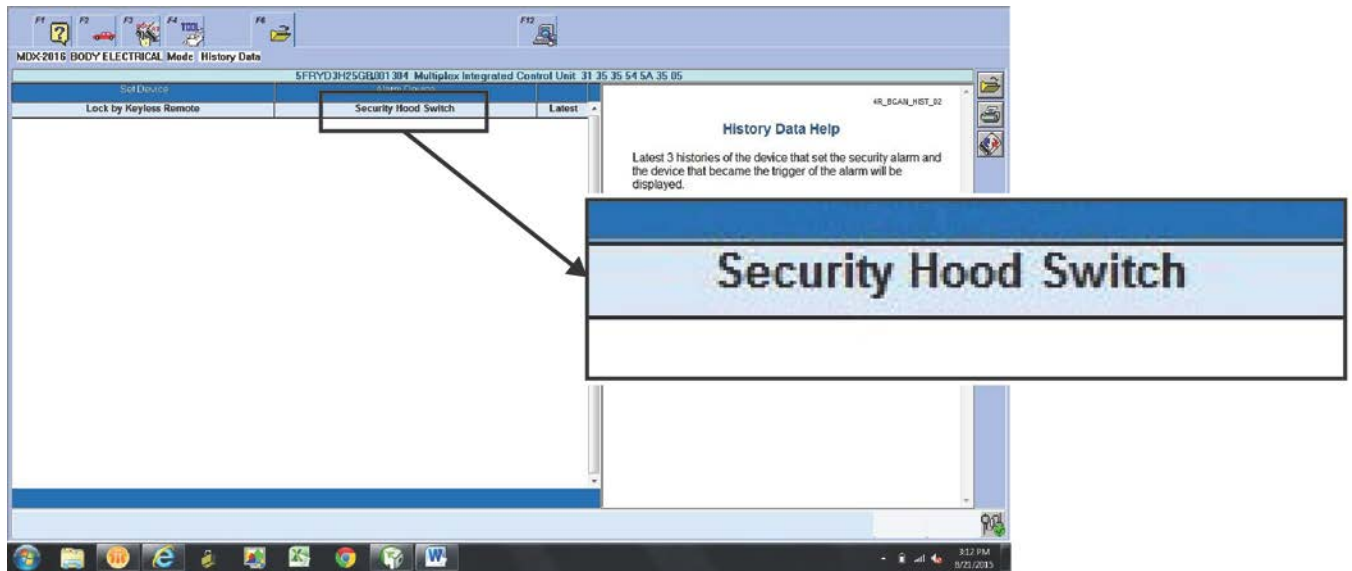

2. If the client complaint is "Security system will not arm", "Parking lights do not flash when setting security system", or "No feedback beep when pressing the lock button twice". Duplicate the complaint, then check the **Body Electrical Data List** using the HDS with the hood closed. If the Security Hood Switch signal reads **ON** (green) go to REPAIR PROCEDURE. If the Security Hood Switch **OFF** (red), this bulletin does not apply

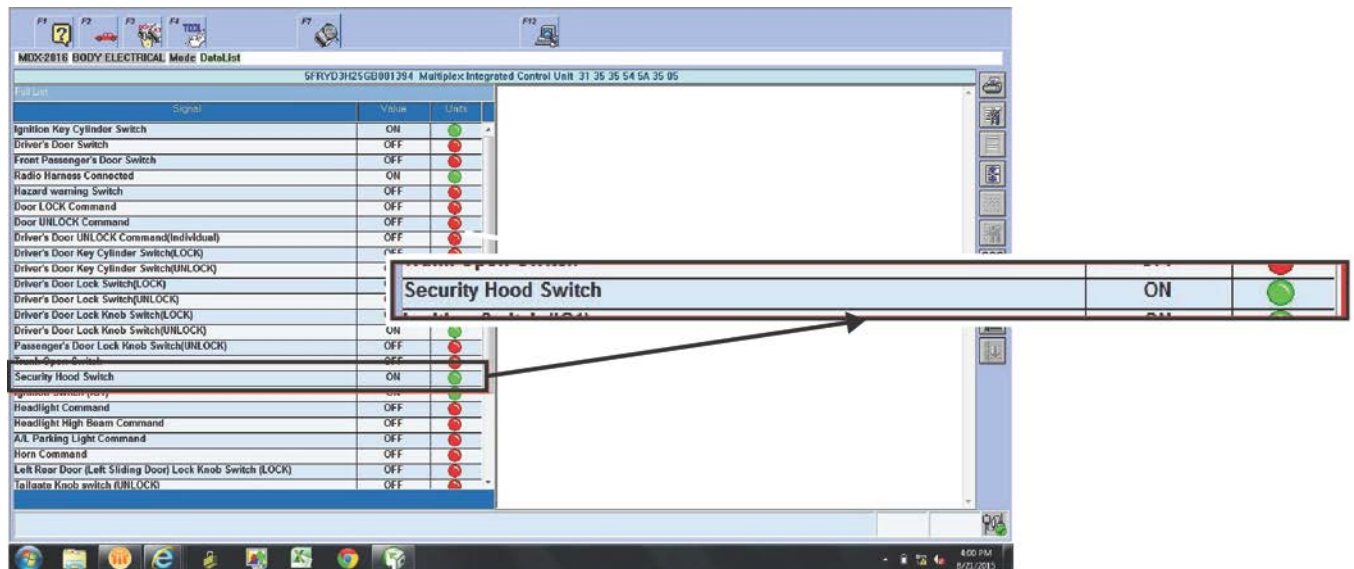

REPAIR PROCEDURE

1. Remove the front bulkhead cover. Starting on the passenger side, lift up the far edge of the cover.

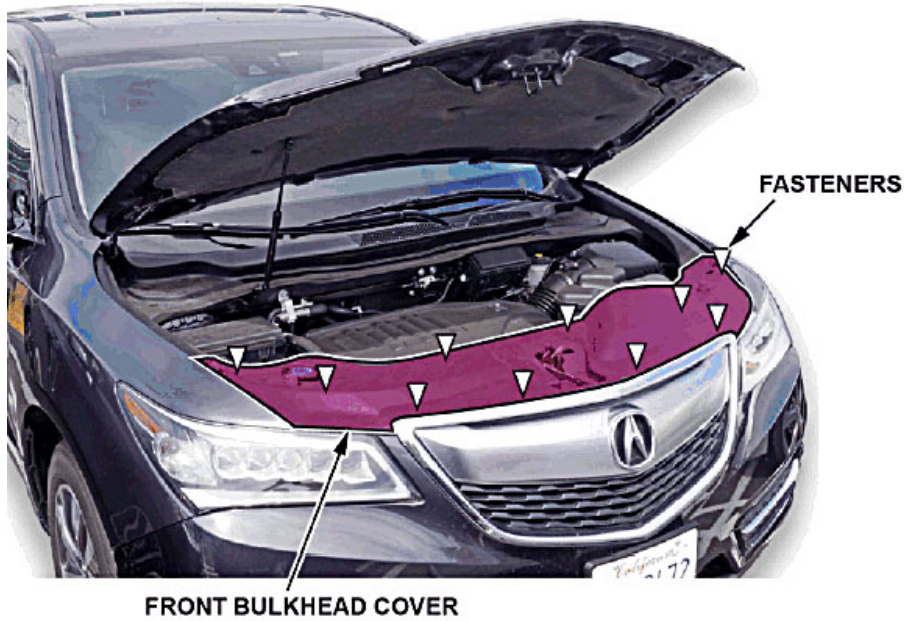

2. Using even, upward pressure, continue releasing the fasteners, working your way toward the driver's side of the cover.

NOTE: Make sure all of the fasteners remain in place.

3. Remove the hood latch:
 - Disconnect the hood opener cable from the latch.
 - Disconnect the hood latch switch connector.

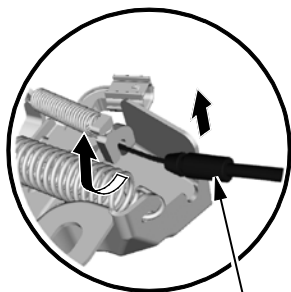

HOOD OPENER
CABLE

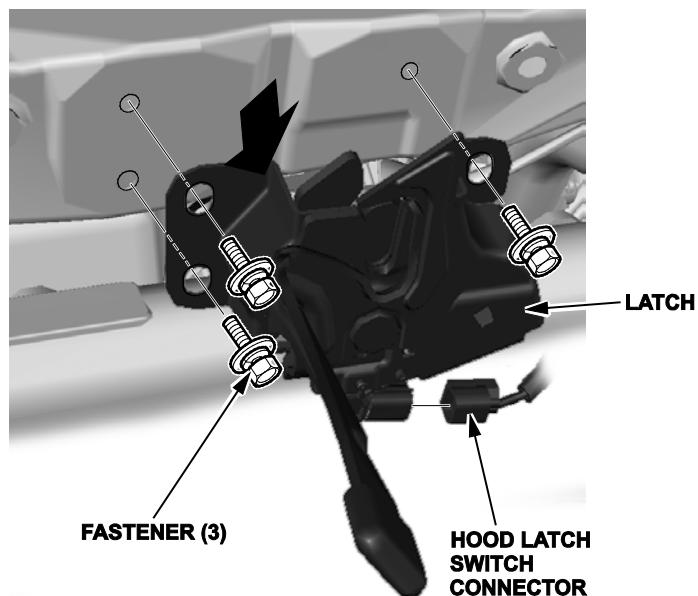

4. Install the new hood latch in the reverse order of the removal, and apply multipurpose grease as indicated.

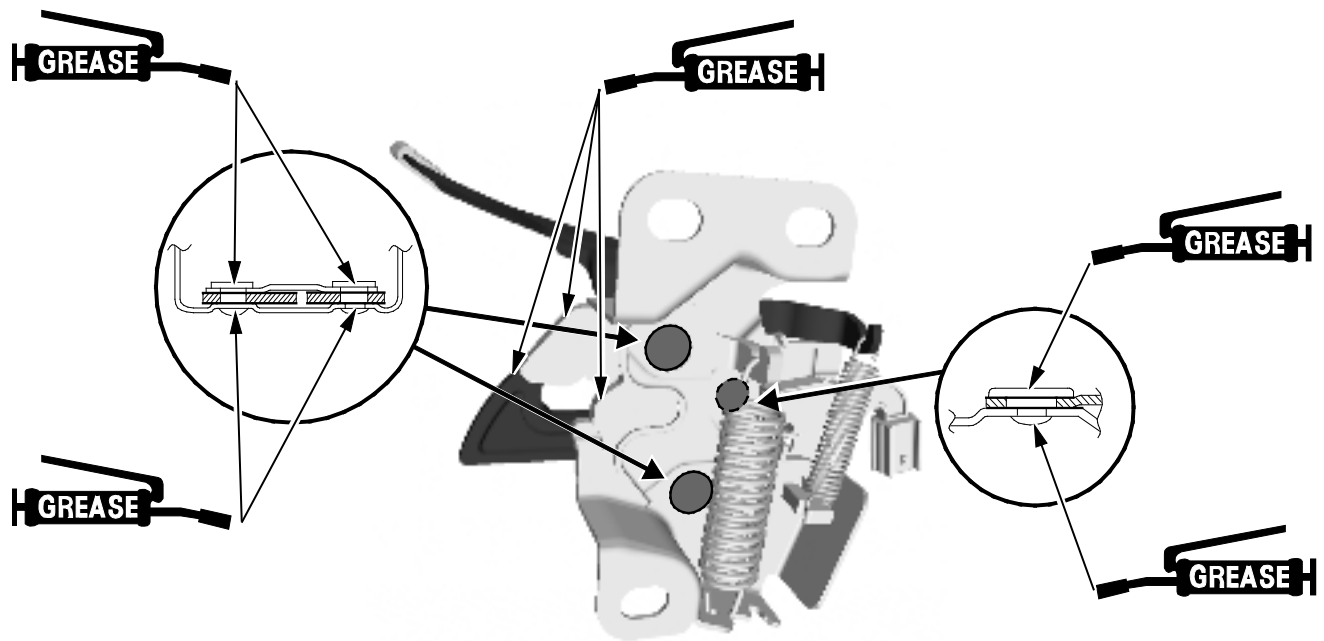

5. Reinstall the bulkhead cover into position in the reverse order of removal, then press down firmly at each of the 10 fasteners locations until you hear a click.

END