

May 30, 2015

01710 Version 1

Rear Cylinder Head Cover Gasket Leaks Oil

AFFECTED VEHICLES

Year	Model	Trim	VIN Range
2003–14	Accord V6	EX-L	ALL
2015	Accord V6	EX-L, 2-Door	1HGCT2...FA000001 thru 1HGCT2...FA002573
2015	Accord V6	EX-L, 4-Door	1HGCR3...FA000001 thru 1HGCR3...FA009704
2015	Accord V6	Touring	1HGCR3...FA000001 thru 1HGCR3...FA009503

SYMPTOM

The rear cylinder head cover gasket leaks oil.

POSSIBLE CAUSES

The rear cylinder head cover gasket shifted during installation.

CORRECTIVE ACTION

Replace the rear cylinder head cover gasket.

PARTS INFORMATION

Part Name	Part Number	Quantity
Rear Cylinder Head Cover Gasket	12351-5G0-A00	1
Intake Manifold Gasket	17105-RCJ-A01	1
Intake Manifold Cover Gasket (upper)	17112-5G0-A01	1

REQUIRED MATERIALS

Part Name	Part Number	Quantity
Liquid Gasket (One tube repairs about 20 vehicles).	08718-0004	1/20 of a tube

WARRANTY CLAIM INFORMATION

The normal warranty applies.

Operation Number	Description	Flat Rate Time	Template ID	Failed Part Number
1101D6	Replace the rear cylinder head cover gasket.	1.1 hrs	15-020A	12320-5G0-A00

Defect Code: 07408

Symptom Code: 05101

Skill Level: Repair Technician

CUSTOMER INFORMATION: The information in this bulletin is intended for use only by skilled technicians who have the proper tools, equipment, and training to correctly and safely maintain your vehicle. These procedures should not be attempted by "do-it-yourselfers," and you should not assume this bulletin applies to your vehicle, or that your vehicle has the condition described. To determine whether this information applies, contact an authorized Honda automobile dealer.

REPAIR PROCEDURE

1. Remove the intake manifold. Refer to the electronic service manual.
2. Remove the three ignition coils from the rear cylinder head. Refer to the electronic service manual.
3. Remove the rear cylinder head cover. Refer to the electronic service manual.

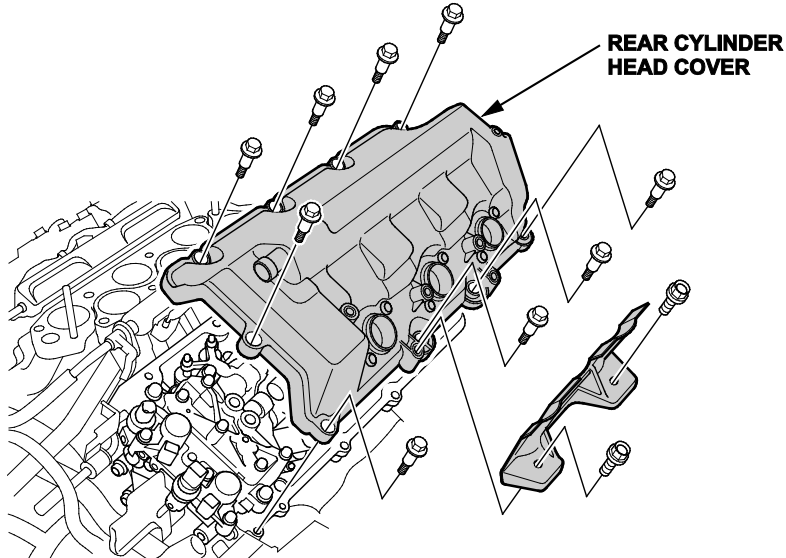

4. Remove the head cover gasket from the rear cylinder head cover.
5. Remove any dirt or debris from the cover and its mounting surface.
6. Clean the cover groove. Install the new head cover gasket in the groove and make sure it seated securely.

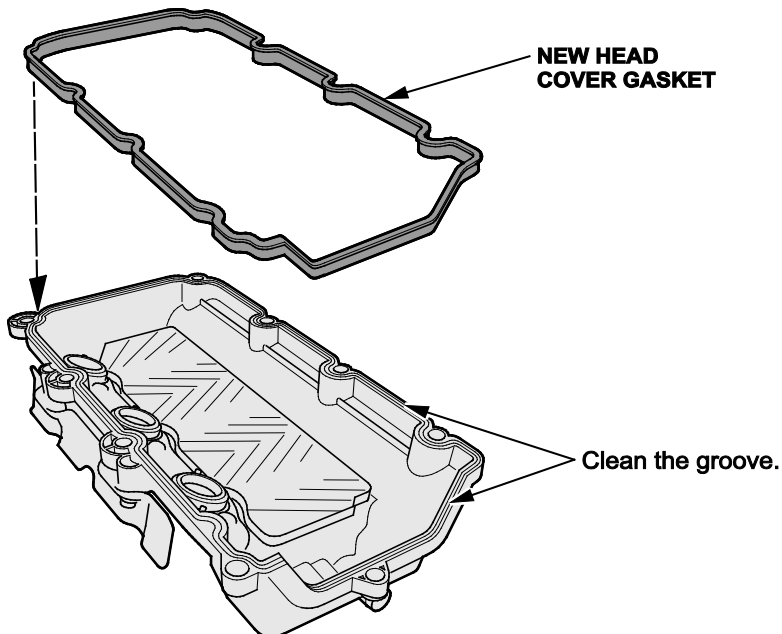

7. Apply liquid gasket on the chain case and the No. 5 rocker shaft holder mating surfaces. Then, install the head cover within 5 minutes of applying the liquid gasket.

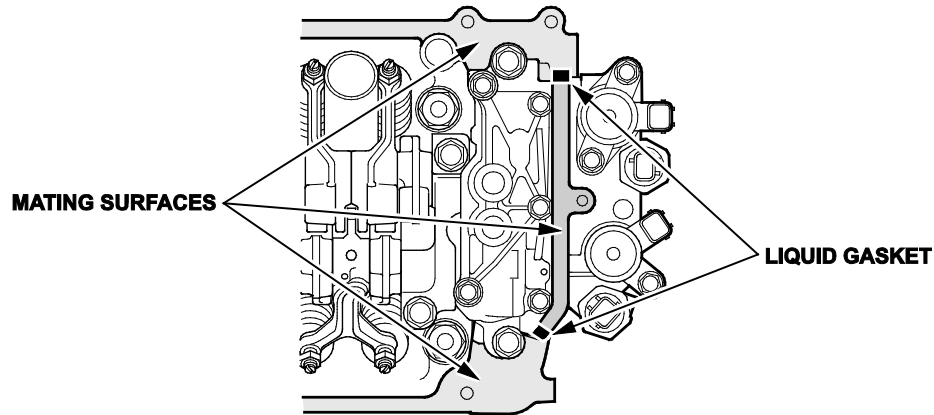

8. Set the spark plug seals in the spark plug tubes and install the rear cylinder head cover.

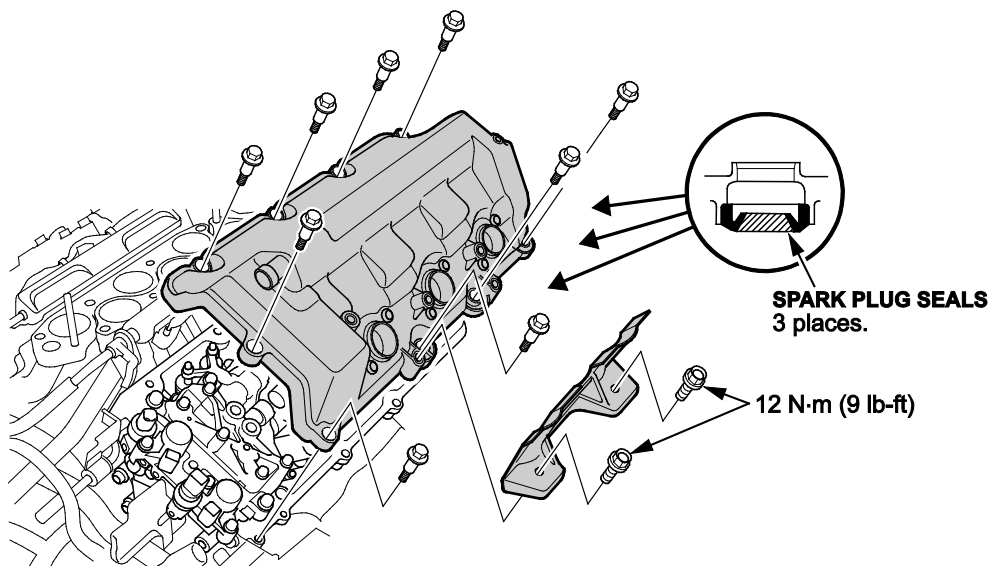

9. Inspect the plug seals for any damage.

10. Torque the bolts in three steps. In the final step, torque them to **7 N·m (5 lb-ft)** in the sequence shown.

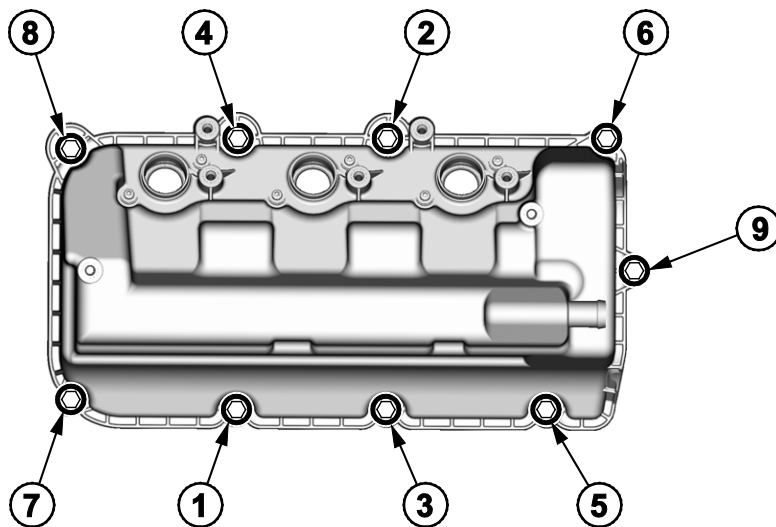

11. Install the intake manifold and torque the bolts and nuts in three steps to **22 N·m (16 lb-ft)**,

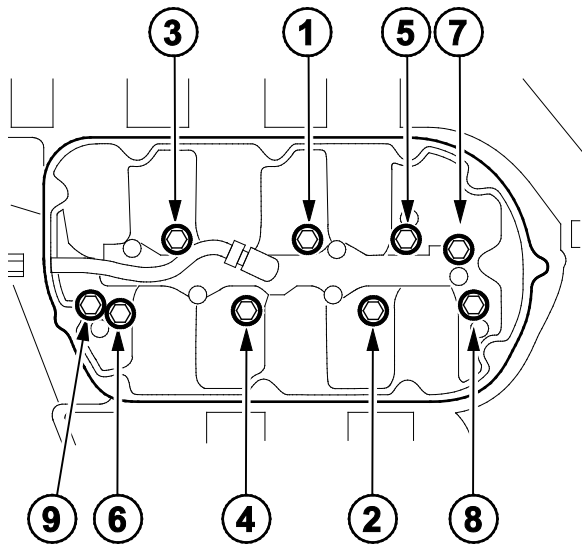

12. Install the intake manifold upper cover and torque the bolts and nuts in three steps to **12 N·m (9 lb-ft)**.

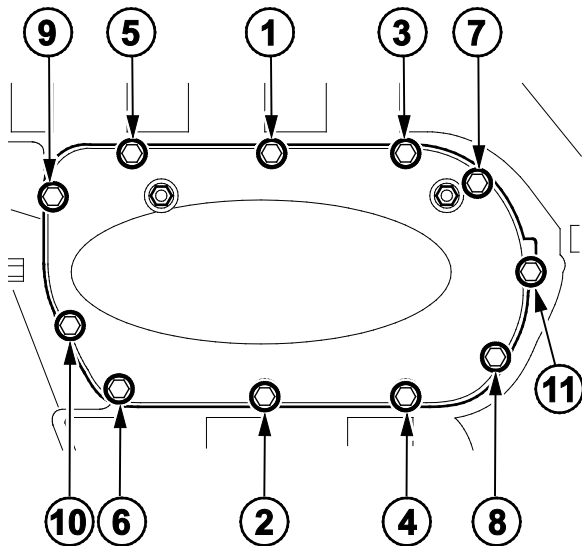

13. Reinstall all removed parts.

END.