

December 20, 2014

ATB 01216 (1412)

Power Sliding Door(s) Get Stuck in the Unlocked Position

AFFECTED VEHICLES

Year	Model	Trim	VIN Range
2014	Odyssey	ALL except LX	ALL

SYMPTOM

The power sliding door gets stuck in the unlocked position.

POSSIBLE CAUSES

The lock knob lever rotates too much, and gets stuck behind the micro switch for the lock.

CORRECTIVE ACTION

Replace the power sliding door remote control assembly.

PARTS INFORMATION

Part Name	Part Number	Quantity
Left Remote Control Assembly	72662-TK8-A31ZA	1
Right Remote Control Assembly	72622-TK8-A31ZA	1

WARRANTY CLAIM INFORMATION

The normal warranty applies.

Operation Number	Description	Flat Rate Time	Template ID	Failed Part Number
8171B8	Replace the left power sliding door remote control assembly.	0.5 hr	14-082A	72662-TK8-A31ZA
8171B9	Replace the right power sliding door remote control assembly.	0.5 hr	14-082B	
8171E2	Replace both power sliding door remote control assemblies.	0.9 hr	14-082C	

Defect Code: 03214

Symptom Code: 08201

Skill Level: Repair Technician

CUSTOMER INFORMATION: The information in this bulletin is intended for use only by skilled technicians who have the proper tools, equipment, and training to correctly and safely maintain your vehicle. These procedures should not be attempted by "do-it-yourselfers," and you should not assume this bulletin applies to your vehicle, or that your vehicle has the condition described. To determine whether this information applies, contact an authorized Honda automobile dealer.

REPAIR PROCEDURE

1. Open the sliding door as needed.
2. Pull off the retainer of the inner handle shaft with a hook-shaped tool and remove the inner handle.

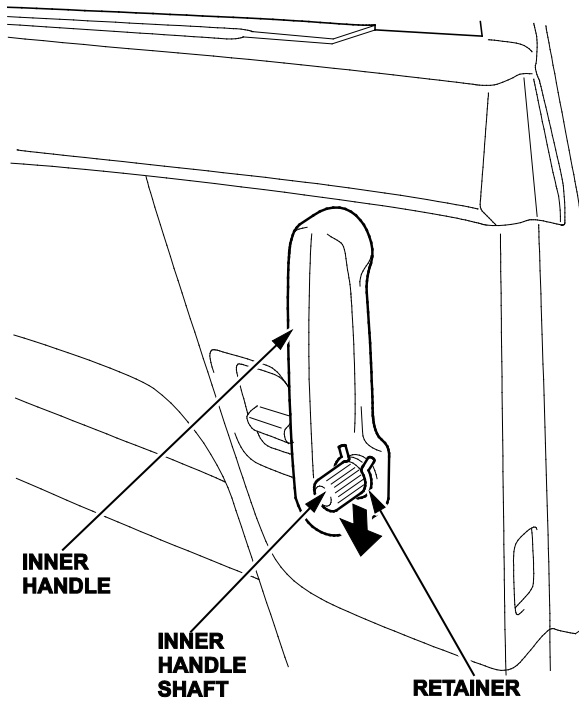

3. Detach the clips, then remove the sliding door sash inner trim.

FASTENER LOCATIONS

▷ 3 CLIPS

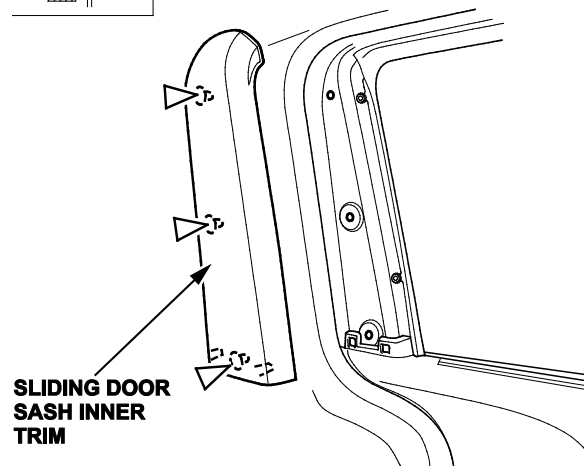
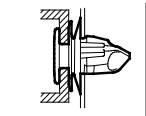

4. Remove the door panel with as little bending as possible to avoid creasing or damaging it.
 - Detach the clips with a trim pad remover.
 - Pull the door panel away from the inner handle shaft.
 - Starting at the rear, pull the door panel upward.
 - While holding the door panel away from the door, disconnect the power window switch connector.

FASTENER LOCATIONS

▷ 14 CLIPS

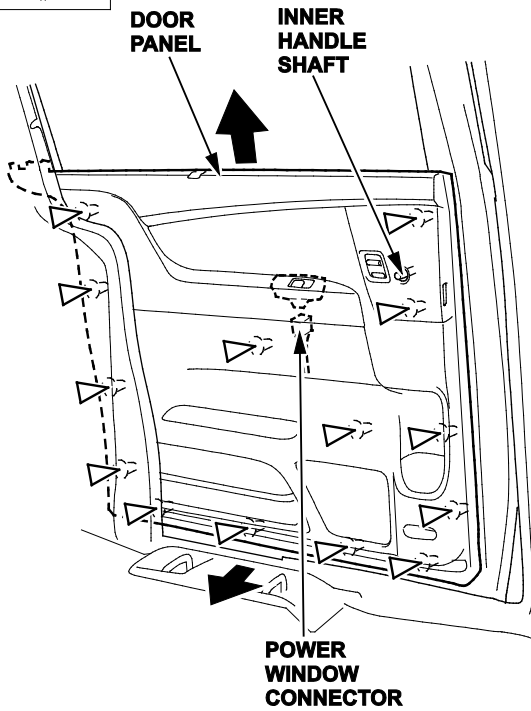
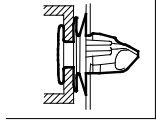

5. Remove the latch remote control assembly from the door.

- Disconnect the remote control assembly connectors.
- Release the cable holders and disconnect the outer handle cable, lower roller cable, front latch cable, and rear latch cable.
- Remove the bolts and the screw.
- Detach the harness clip and release the hook.

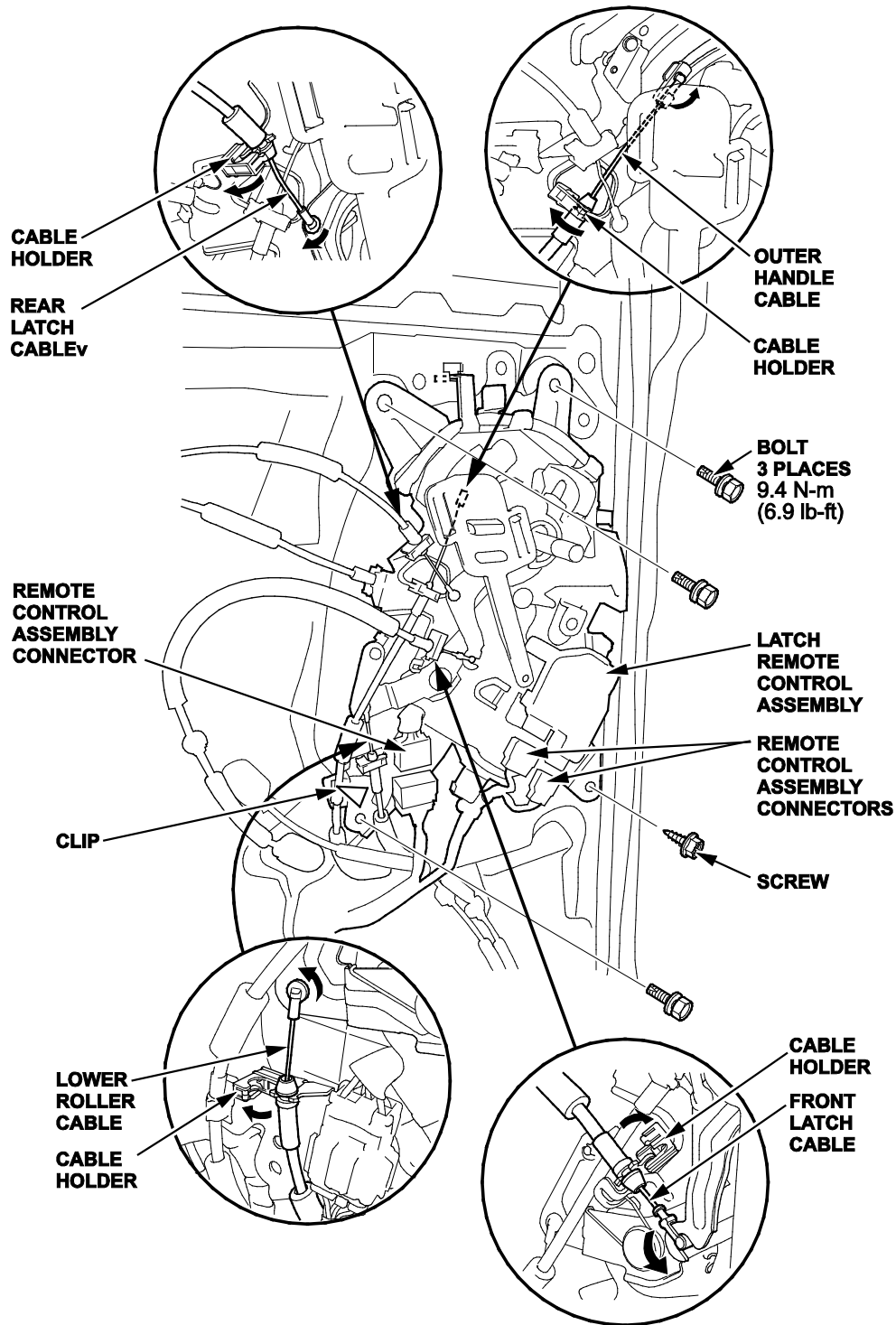

6. Release the cable holder and disconnect the failsafe lever cable from the latch remote control assembly.

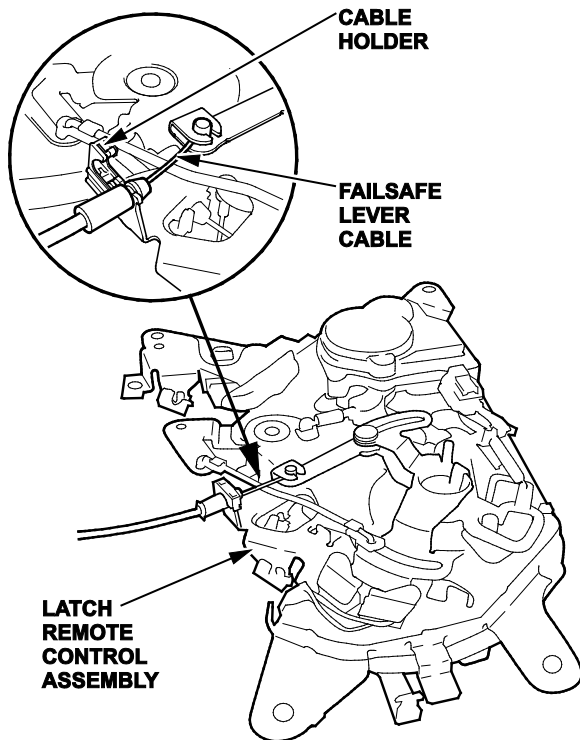

7. Install the new latch remote control assembly and torque the bolts to **9.4 N·m (6.9 lb-ft)**
8. Install the door panel in the reverse order of removal.

NOTE:

- Make sure each connector is plugged in properly and each cable is routed properly and connected securely.
 - Take care not to bend any of the cables.
 - Make sure the door locks and opens properly.
 - If the clips are damaged or stress-whitened, replace them with new ones.
 - Push the clips and the hooks into place securely.
9. Repeat steps 1 through 8 on the other sliding door if needed.

END