



Applies To: **2007–09 Odyssey – ALL**  
**2010 Odyssey – From VIN 5FNRL3...AB000001 thru 5FNRL3...AB028891**

May 16, 2012

## Clunking, Popping, or Clicking While Turning

(Supersedes 10-042, dated August 14, 2010, to revise the information marked by the black bars)

### REVISION SUMMARY

- Under PARTS INFORMATION, the part numbers for driveshaft assemblies were changed, and the part number for the spindle nuts was added.
- Under REPAIR PROCEDURE, step 26, information was added about checking the ATF level and test-driving the vehicle.

### SYMPTOM

There is a clunking, popping, or clicking noise from the front of the vehicle while turning.

### PROBABLE CAUSE

The outer CV joints are faulty.

### CORRECTIVE ACTION

Replace the driveshaft assembly.

### PARTS INFORMATION

Castle Nut, 14 mm (two required):  
P/N 90363-S3V-A01

Driveshaft Assembly:

Left: P/N 44306-SHJ-L01

Right: P/N 44305-SHJ-L01

Set Ring, 30 x 2.2 mm (For right driveshaft replacement intermediate shaft):  
P/N 44319-S0X-A01

Spindle Nut, (one per side):  
P/N 90305-S3V-A11

### TOOL INFORMATION

Ball Joint Remover, 32 mm:  
T/N 07MAC-SL0A102

Ball Joint Thread Protector, 14 mm:  
T/N 071AF-S3VA000

### REQUIRED MATERIALS

Moly 60 Paste:

P/N 08734-0001

(One tube repairs about five vehicles.)

Super High Temp Urea Grease:

P/N 08798-9002

(One container repairs about five vehicles.)

### WARRANTY CLAIM INFORMATION

The normal warranty applies.

OP#	Description	FRT
219131	Replace the left driveshaft.	0.6
219132	Replace the right driveshaft.	0.6
219130	Replace the left and right driveshafts.	1.2
C	Add for wheel alignment.	0.4

Failed Part: P/N 44305-SHJ-C01

Defect Code: 07404

Symptom Code: 04201

### DIAGNOSIS

Test-drive the vehicle, and listen for a clunking, popping, or clicking noise while turning. If you can duplicate the noise, try to determine which side the noise is coming from. If you are unable to confirm which side is faulty, raise the vehicle on a lift (all four wheels off the ground).

Turn the steering wheel from side to side while the front wheels are turning:

- Once you have determined which side is faulty, go to REPAIR PROCEDURE.
- If you do not hear the noise, continue with normal troubleshooting.

## REPAIR PROCEDURE

NOTE: This procedure is in an outline form that you can also use as a checklist for the repair. If you need more details on the topics listed below, bookmark them in the *2007–2010 Odyssey Service Manual*, or view them online:

- Stabilizer Link Removal/Installation
- Lower Arm Removal/Installation
- Ball Joint Removal

1. Raise and support the vehicle.
2. Remove the front wheel for the affected side.
3. Pry up the shoulder on the spindle nut, then remove the nut.

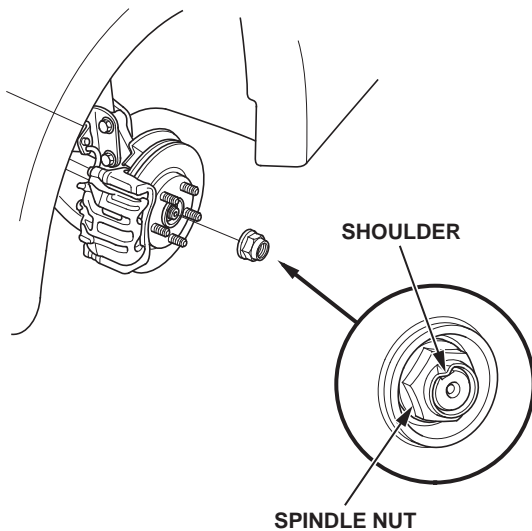

4. Separate the front stabilizer link from the damper.
5. Remove the lock pin from the lower arm ball joint castle nut, then remove the nut, and separate the ball joint from the lower arm using the ball joint thread protector and the ball joint remover.

### NOTE:

- To avoid damaging the ball joint, install the ball joint thread protector onto the threads of the ball joint. Also, do not force or hammer on the lower arm, or pry between the lower arm and the knuckle.
- Be careful not to damage the ball joint boot when installing the remover.

6. Pull the knuckle outward, and separate the driveshaft outboard joint from the front hub using a plastic hammer.

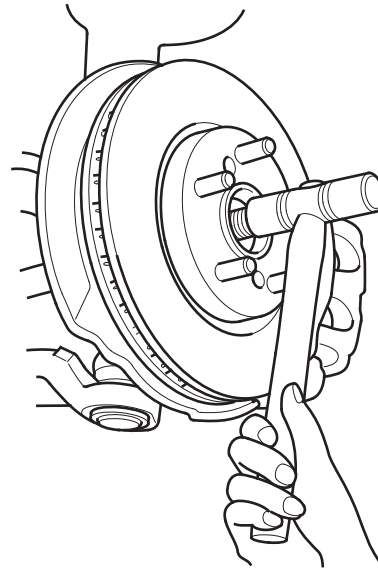

7. *Left driveshaft:* Place a drain pan under the transmission to catch any ATF that may come out during driveshaft removal.
8. *Left driveshaft:* Pry the inboard joint from the differential using a pry bar. Remove the driveshaft as an assembly.

### NOTE:

- Do not pull on the driveshaft, or the inboard joint may come apart. Pull the inboard joint straight out to avoid damaging the oil seal.
- Be careful not to damage the oil seal or the end of the inboard joint when using the pry bar.

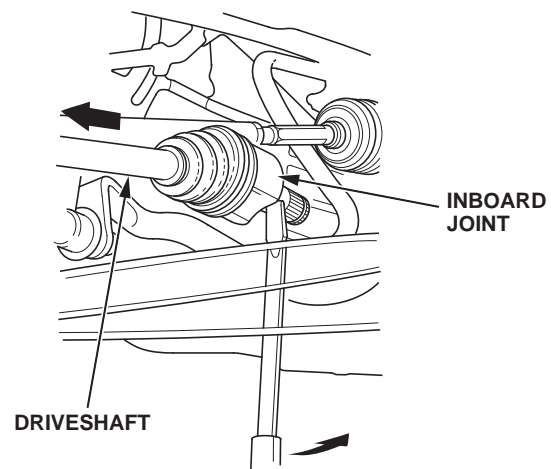

9. *Right driveshaft:* Drive the inboard joint off of the intermediate shaft using a 24-inch or longer striking pry bar (Snap-on SBPS24 or equivalent) and a dead-blow hammer. Remove the driveshaft as an assembly.

NOTE: Do not pull on the driveshaft, or the inboard joint may come apart.

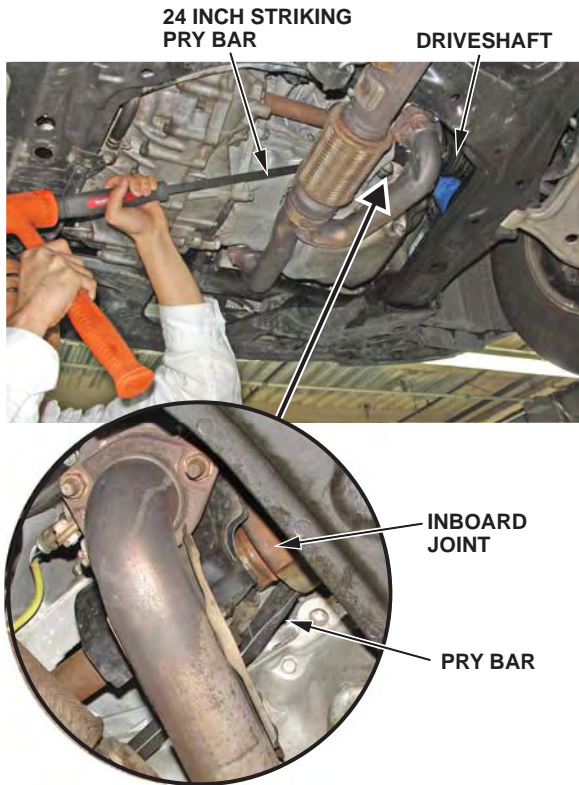

10. *Right driveshaft:* Remove the set ring from the intermediate shaft.

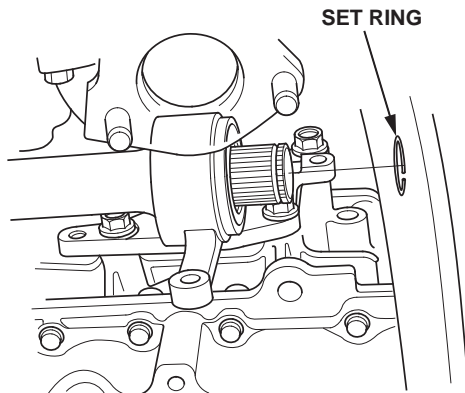

11. Clean all driveshaft joint and splined mating surfaces on the vehicle with solvent, and dry them with compressed air.

NOTE: Do not clean any rubber parts with solvent.

12. Apply about 5 g of Moly 60 Paste to the contact area of the outboard joint and the front wheel bearing.

NOTE: The paste helps to prevent noise and vibration.

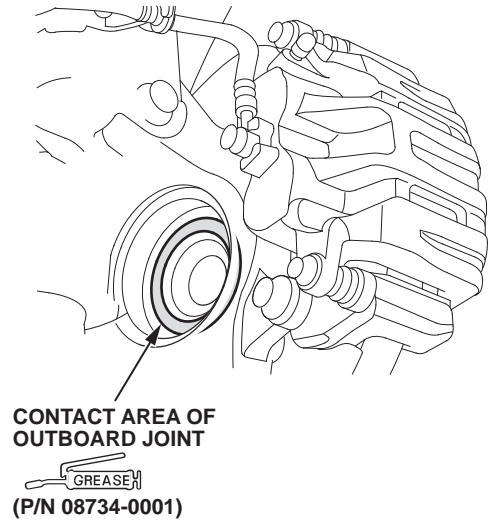

13. *Right driveshaft:* Install a new set ring into the set ring groove of the intermediate shaft.

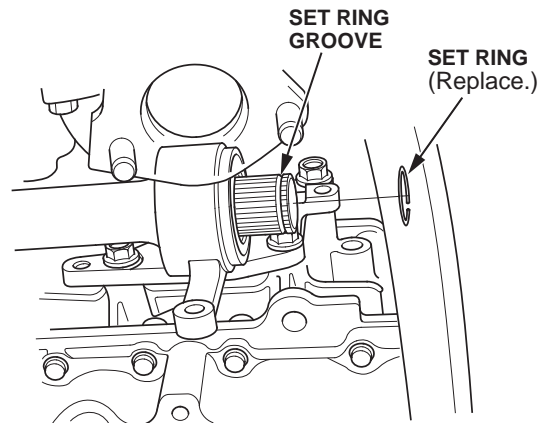

14. *Right driveshaft:* Apply 2 to 3 g of Super High Temp Urea Grease to the whole splined surface of the right driveshaft. Then remove the grease from the splined grooves (at intervals of two to three splines) and from the set ring groove. This allows air to bleed from the intermediate shaft during installation and when driving.

**SPLINED SURFACE**  
(Apply grease.)  
P/N 08798-9002

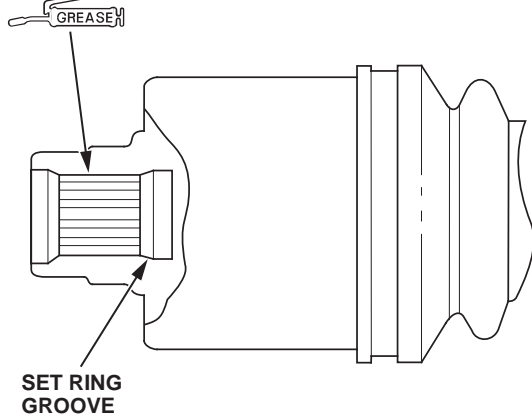

15. Insert the inboard end of the driveshaft into the differential or onto the intermediate shaft until the set ring locks into the groove.

NOTE: To prevent oil seal damage, insert the driveshaft straight (horizontally) into the differential or the intermediate shaft.

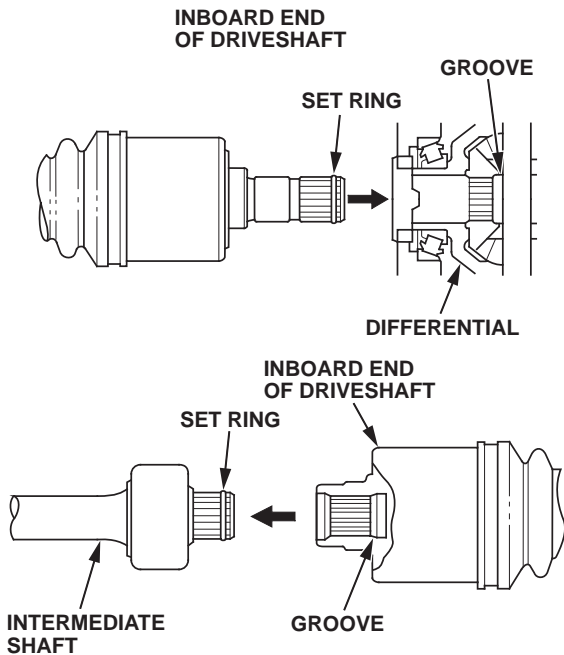

16. Install the outboard joint into the front hub.

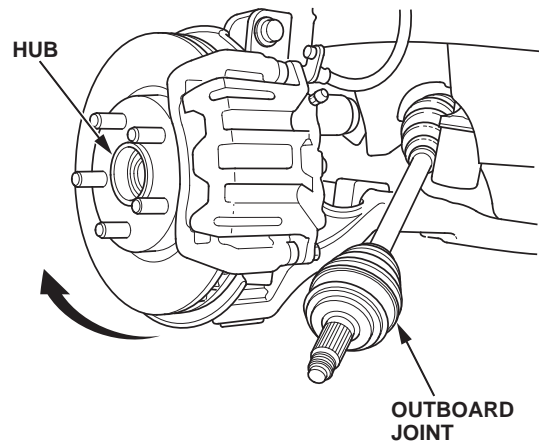

17. Wipe off any grease contamination from the ball joint tapered section and threads, then install the knuckle onto the lower arm. Torque the new castle nut to **59 N·m (43 lb-ft)**, then tighten it only far enough to align the slot with the ball joint pin hole.

NOTE:

- Be careful not to damage the ball joint boot.
- Do not align the castle nut by loosening it.

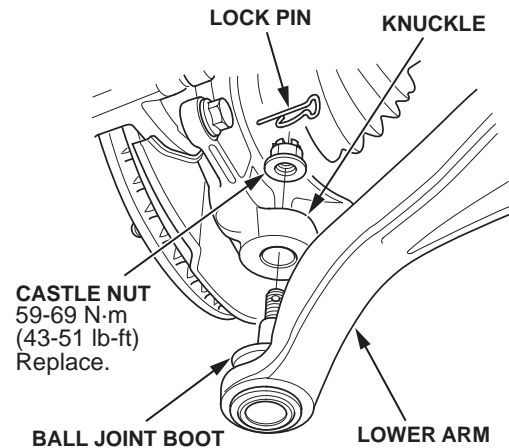

18. Install the lock pin into the ball joint pin hole.

19. Connect the front stabilizer link to the damper. Torque the two flange nuts to **78 N·m (58 lb-ft)**.

20. Apply a small amount of engine oil to the seating surface of a new spindle nut, then install the nut, and torque it to **329 N·m (242 lb-ft)**. After installing the nut, use a drift to stake its shoulder against the driveshaft.

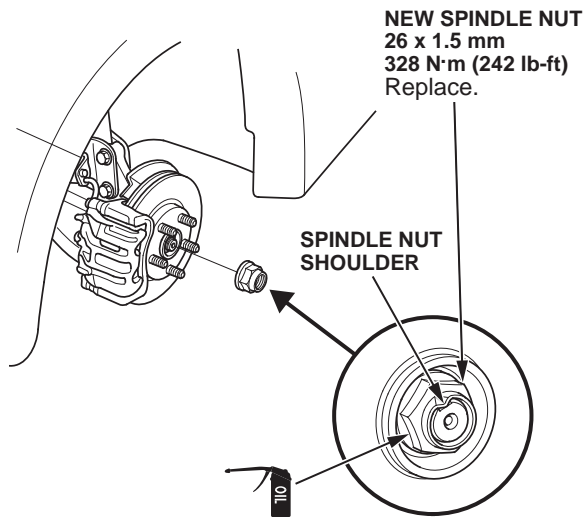

21. Clean the mating surfaces of the brake disc and the wheel, then install the front wheel, and torque the wheel nuts to **127 N·m (94 lb-ft)**.
22. Rotate each of the front wheels by hand, and make sure there is no interference between the driveshafts and the surrounding parts.
23. If needed, repeat steps 2 thru 22 on the other side.
24. Lower the vehicle.
25. Check the wheel alignment, and adjust it if needed.
26. Top off the transmission with the recommended fluid. Check the ATF level, and test-drive the vehicle.