



Product Update: Restricted Heater Core or Radiator Causes Poor Heating or Engine Overheating

(Supersedes 08-097, dated December 18, 2008, to update the information marked by the black bar)

BACKGROUND

Contamination in the factory fill engine coolant can eventually cause restrictions in the heater core and the radiator, leading to poor heater performance or, in rare cases, engine overheating.

VEHICLES AFFECTED

2003 Element:

2WD – From VIN 5J6YH1...3L016392 thru
5J6YH1...3L016482

4WD – From VIN 5J6YH2...3L039455 thru
5J6YH2...3L051852

2004 Element:

2WD – From VIN 5J6YH1...4L015490 thru
5J6YH1...4L015549

4WD – From VIN 5J6YH2...4L000271 thru
5J6YH2...4L039015

2005 Element:

2WD – From VIN 5J6YH1...5L000430 thru
5J6YH1...5L001027

4WD – From VIN 5J6YH2...5L000612 thru
5J6YH2...5L001811

Not all vehicles within the affected VIN ranges have contaminated coolant. To verify vehicle eligibility, you must check at least one of these items:

- The customer has a notification letter.
- The vehicle is shown as eligible on a VIN status inquiry.

In addition, check for a punch mark above the first character of the engine compartment VIN. A punch mark in that location means this product update has already been completed.

Some of the vehicles affected by this product update may be in your used vehicle inventory. These vehicles should be updated before they are sold or leased.

CUSTOMER NOTIFICATION

All owners of affected vehicles will be sent a notification of this product update. An example of the customer notification is at the end of this service bulletin.

CORRECTIVE ACTION

Inspect the engine coolant and, depending on the condition of the coolant and the heater core, do one of these repairs:

- Replace the coolant.
- Replace the radiator, the water bypass hoses, and the heater breather hose, and drain/refill the coolant.
- Replace the radiator, the water bypass hoses, the heater breather hose, and the heater core, and drain/refill the coolant.

PARTS INFORMATION

Radiator:

M/T vehicles -

P/N19010-PZD-A01, H/C 7272057

A/T vehicles -

P/N19010-PZD-A51, H/C 7272065

Heater Core:

P/N 79110-S9A-A01, H/C 6902142

Water Bypass Inlet Hose (RACV Inlet Hose):

P/N 19508-PZD-A00, H/C 7305113

Water Bypass Outlet Hose (RACV Outlet Hose):

P/N 19509-RAA-A00, H/C 7133747

Heater Breather Hose:

P/N 19514-PZD-A00, H/C 7305121

REQUIRED MATERIALS

Honda Genuine Long Life Antifreeze/Coolant
Type 2 Blue: P/N OL999-9011, H/C 7792401

Inspection only: 1.5 gallons per vehicle.

Repair: 6 gallons per vehicle.

WARRANTY CLAIM INFORMATION

NOTE: This product update ends on December 18, 2011. After that, any applicable warranty would apply.

OP#	Description	FRT
1140A1	Inspect and replace the engine coolant.	0.3
B	Add: Replace the radiator, the water bypass hoses, and the heater breather hose; drain/refill the coolant.	2.4
C	Add: Replace the heater core, the radiator, the water bypass hoses, and the heater breather hose; drain/refill the coolant.	9.2

Failed Part: P/N 19010-PZD-A51
H/C 7272065
Defect Code: 5HE00
Symptom Code: Q9200
Skill Level: Repair Technician

INSPECTION PROCEDURE

1. Drain the engine coolant into a clean container:
 - Refer to page 10-6 of the *2003–2006 Element Service Manual*, and do steps 1 thru 4, or
 - Online, enter keyword **COOLANT**, select **Coolant Replacement** from the list, and do steps 1 thru 4.
2. Check the clarity and the color of the drained coolant:
 - If the coolant is clear, and its color is bright blue or bright green, go to step 3.
 - If the coolant is cloudy, or if its color is not bright blue or bright green, go to REPAIR PROCEDURE.

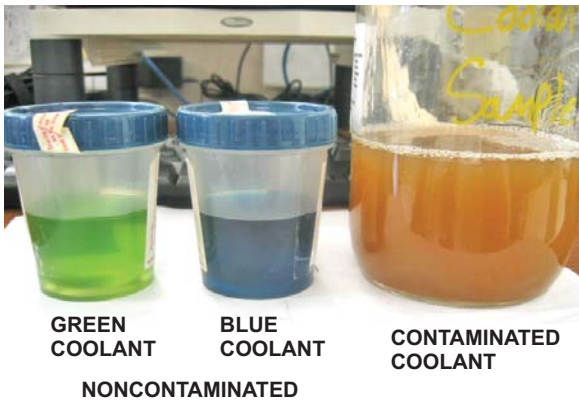

3. Remove the radiator cap, and check for corrosion at the cap opening:
 - If there is no corrosion at the cap opening, go to step 4.
 - If you see corrosion at the cap opening, go to REPAIR PROCEDURE.

OK: No Corrosion

NG: Corrosion

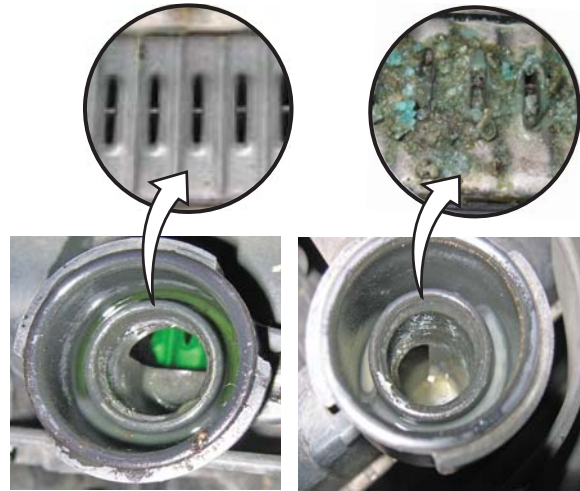

4. Add new coolant into the radiator:
 - Refer to page 10-7 of the service manual, and do steps 5 thru 12, or
 - Online, enter keyword **COOLANT**, select **Coolant Replacement** from the list, and do steps 5 thru 12.
5. Center-punch a completion mark above the first character of the engine compartment VIN.

Center-punch here.



REPAIR PROCEDURE

NOTE: Do a VIN status inquiry to see if the heater core was already replaced. (It may have been replaced using Service Bulletin 07-076, *Poor Heating Due to Restricted Heater Core*.) If the heater core was replaced, do not do step 2.

1. Replace the radiator:
 - Refer to page 10-13 in the *2003–2006 Element Service Manual*, and do steps 2 thru 9, or
 - Online, enter keyword **RADIATOR**, select **Radiator and Fan Replacement** from the list, and do steps 2 thru 9.
2. Replace the heater core:
 - Refer to page 21-43 in the service manual, or
 - Online, enter keywords **HEATER UNIT**, and select **Heater Unit/Core Replacement** from the list.

3. Replace the water bypass (RACV) inlet and outlet hoses and the heater breather hose.

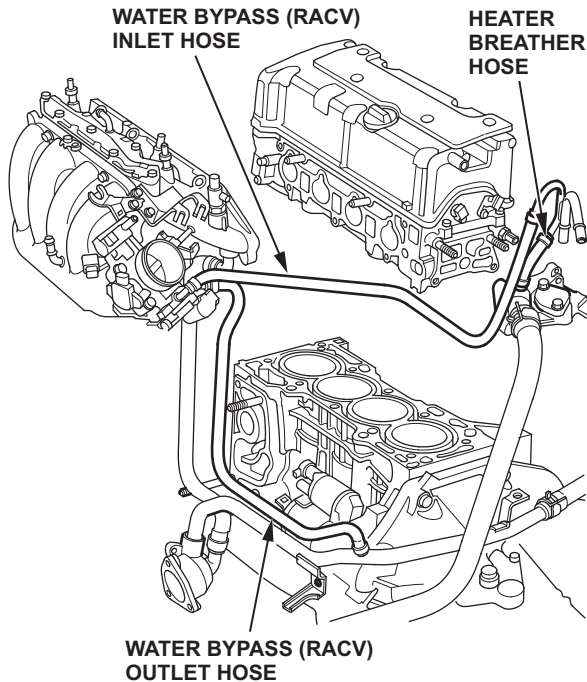

4. Add about 1.5 gallons of coolant to the radiator, then install the radiator cap.
5. Start the engine, and let it reach normal operating temperature (the cooling fans cycle twice).
6. Shut the engine off, and open the radiator petcock one turn.
7. Monitor the cooling system pressure by lightly squeezing the upper radiator hose. Once the hose walls touch, remove the radiator cap and fully open the petcock. After the coolant is completely drained, tighten the petcock.
8. Add about 1.5 gallons of coolant to the radiator.
9. Start the engine, top off the coolant in the radiator if needed, then reinstall the radiator cap.
10. Let the engine idle for about 10 minutes.
11. Repeat steps 6 thru 10 two more times to remove any remaining contamination from the cooling system.
12. Tighten the radiator cap, then run the engine again and check for leaks.
13. Operate the heater, and make sure that warm air is coming from the vents.
14. Center-punch a completion mark above the first character of the engine compartment VIN.

Center-punch here.

5J6YHXXXXXXXXXXXX

Winter 2008

Product Update: Heater Is Not Warm Enough or Engine Overheats

Dear Element Owner:

This letter is to notify you of a potential problem with your vehicle and what you should do to resolve it.

What is the problem?

Contamination in the factory fill engine coolant can eventually cause restrictions in the heater core and the radiator, leading to poor heater performance or engine overheating.

What should you do?

Contact any authorized Honda dealer for an appointment to have your vehicle updated. The dealer will inspect your vehicle's cooling system, replace any needed parts, and install new engine coolant. This work will be done *free of charge*. Please plan to leave your vehicle at the dealer for half a day or more to allow some flexibility in scheduling.

This product update ends on December 18, 2011. After that, any applicable warranty would apply.

What to do if you feel this notice is in error

Our records show that you are the current owner or lessee of a 2003–05 Element involved in this product update. If this is not the case, or the name/address information is not correct, please fill out and return the enclosed, postage-paid Information Change Card. We will then update our records.

If you previously paid to have the heater core or the radiator repaired or replaced, you may be eligible for reimbursement. Refer to the attached Instructions for Reimbursement for eligibility requirements and the reimbursement procedure.

If you have questions

If you have questions about this notice, or need help contacting a Honda dealer, please call Honda Automobile Customer Service at 800-999-1009.

We apologize for any inconvenience this product update may cause you.

Sincerely,

**American Honda Motor Co., Inc.
Honda Automobile Division**