

FORD:

2011-2016 F-Super Duty

ISSUE

Some 2011-2016 F-Super Duty crew cab pickup vehicles equipped with an 8 foot box and a factory trailer hitch may exhibit a vertical vibration, often described as hopping, from 68-112 Km/h (42-70 MPH).

ACTION

Follow the Service Procedure steps to correct the condition.

SERVICE PROCEDURE

1. Does the customer describe a vibration, which may be described as hopping, at approximately 68-110 Km/h (42-70 MPH)?
 - a. Yes - proceed to Step 2.
 - b. No - this article does not apply. Refer to Workshop Manual (WSM), Section 100-04 for normal diagnostics.
2. Does the vehicle have a cage damper mounted to the factory trailer hitch on the driver side? (Figure 1)

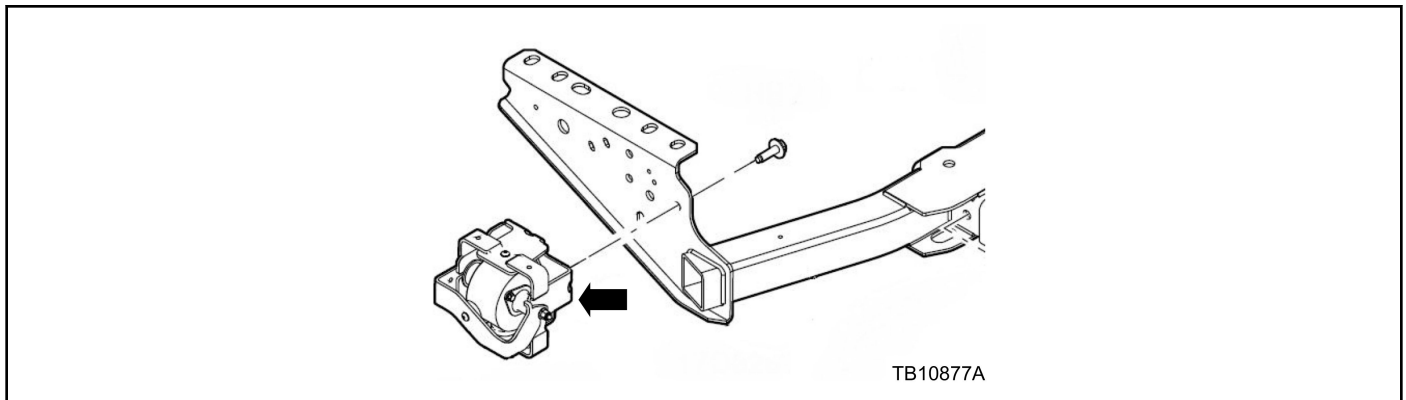

Figure 1 - Article 16-0087

- a. Yes - this article does not apply. Refer to WSM, Section 100-04 for normal diagnostics.
 - b. No - proceed to Step 3.
3. Remove the wiring connector on the driver side of the trailer hitch. (Figure 2)

NOTE: The information contained in Technical Service Bulletins is intended for use by trained, professional technicians with the knowledge, tools, and equipment to do the job properly and safely. It informs these technicians of conditions that may occur on some vehicles, or provides information that could assist in proper vehicle service. The procedures should not be performed by "do-it-yourselfers". Do not assume that a condition described affects your car or truck. Contact a Ford, Lincoln, or Mercury dealership to determine whether the bulletin applies to your vehicle. Warranty Policy and Extended Service Plan documentation determine Warranty and/or Extended Service Plan coverage unless stated otherwise in the TSB article. The information in this Technical Service Bulletin (TSB) was current at the time of printing. Ford Motor Company reserves the right to supersede this information with updates. The most recent information is available through Ford Motor Company's on-line technical resources.

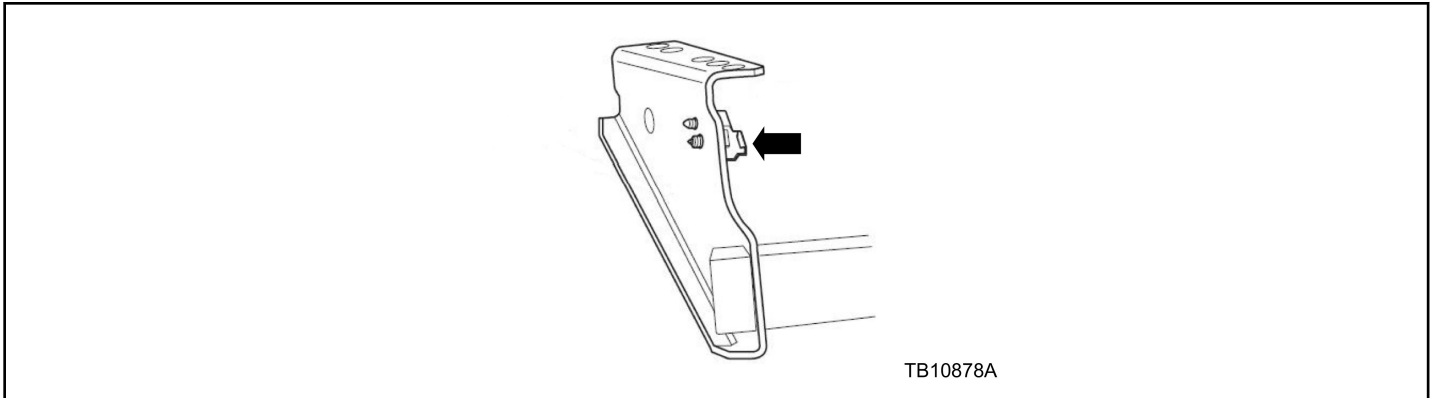

Figure 2 - Article 16-0087

4. Locate in the driver side plate of the trailer hitch the following holes. (Figure 3)
 - a. Clearance hole 17.6 mm (11/16"). The clearance hole will be used for the cage damper rubber pad. (Figure 3A)
 - b. Three mounting holes 14.6 mm (9/16"). (Figure 3B)

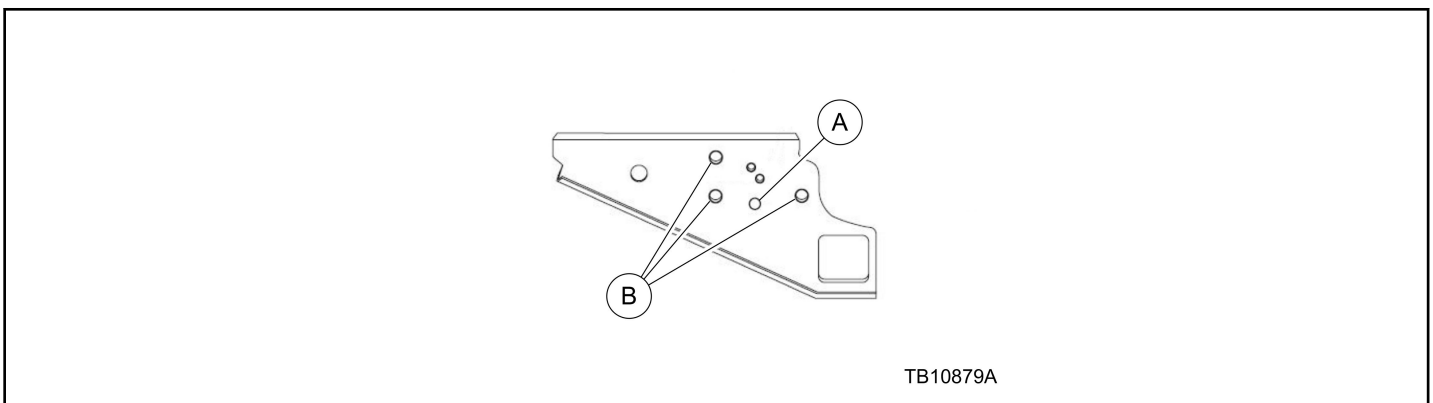

Figure 3 - Article 16-0087

5. Mount the cage damper and install the bolts. Tighten to 63 Nm (46 lb-ft). (Figure 4)

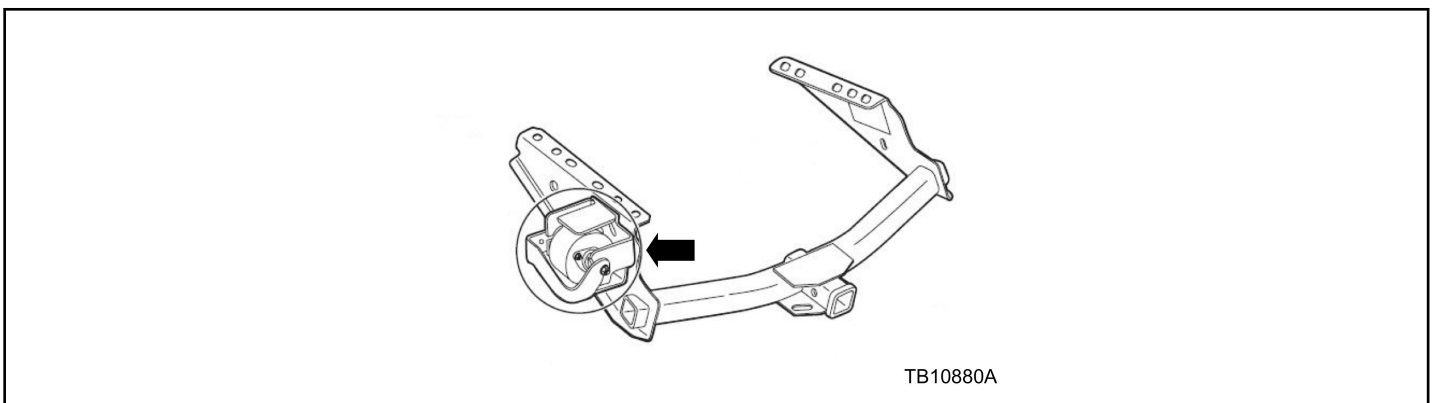

Figure 4 - Article 16-0087

PART NUMBER	PART NAME
9C3Z-5D008-B	Damper Assembly
W706496-S439	Bolt (3 Req)

TSB 16-0087 (Continued)

OPERATION	DESCRIPTION	TIME
160087A	2011-2016 F-Super Duty: Install Cage Damper Following The Service Procedure (Do Not Use With Any Other Labor Operations) (Do Not Use With Any Other Labor Operations Except B Or C)	0.4 Hr.
160087B	2011-2016 F-Super Duty: Extra Time To R&I Fuel Shield To Access Lifting Points (Do Not Use With Any Other Labor Operations Except A)	0.1 Hr.
160087C	2011-2016 F-Super Duty FX4: Extra Time To R&I Fuel Shield To Access Lifting Points (Do Not Use With Any Other Labor Operations Except A)	0.3 Hr.

WARRANTY STATUS:

Eligible Under Provisions Of New Vehicle Limited Warranty Coverage

Warranty/ESP coverage limits/policies/prior approvals are not altered by a TSB. Warranty/ESP coverage limits are determined by the identified causal part and verified using the OASIS part coverage tool.

DEALER CODING

BASIC PART NO.	CONDITION CODE
5D008	42