

**ATTENTION:**  
 GENERAL MANAGER   
 PARTS MANAGER   
 CLAIMS PERSONNEL   
 SERVICE MANAGER

IMPORTANT - All Service Personnel Should Read and Initial in the boxes provided, right.

© 2014 Subaru of America, Inc. All rights reserved.



QUALITY DRIVEN® SERVICE

**SERVICE BULLETIN**

**APPLICABILITY:** 2015 Legacy and Outback Models

**NUMBER:** 10-81-14R

**SUBJECT:** “Whistling” Sound from Center Console Arm Rest Vents

**DATE:** 11/20/14

**REVISED:** 03/19/15

**INTRODUCTION**

This bulletin provides a service procedure to address customer concerns of a “whistling” sound coming from the rear seat air distribution vents located at the rear of the center console. The sound may be heard when the blower speed is set to high. This condition is repaired with the installation of an additional piece of self-adhesive foam tape which will enhance sealing between the vent grille assembly and center air duct.

**PART INFORMATION**

- 1) Piece of self-adhesive foam tape, 1/8” (T) x 3/8” (W) x 11 5/8” (L), available in bulk (10 foot roll) at most hardware stores or home improvement centers. Ace Hardware item# 57625 is shown.



**COUNTERMEASURE IN PRODUCTION:**

A new center air duct, p. n. **92143AL02A** which includes the foam sealing tape was incorporated into production during December, 2014 starting with the following VINs:  
**LEGACY: F\*037681** and **OUTBACK: F\*268342.**

**SERVICE PROCEDURE / INFORMATION**

**REMINDER:** Whenever removing plastic trim panels, **ALWAYS** use a plastic trim tool to avoid damage.

- Remove the forward console compartment side trims shown below using a plastic trim tool to release the 2 retaining claws.



*Continued...*

**CAUTION: VEHICLE SERVICING PERFORMED BY UNTRAINED PERSONS COULD RESULT IN SERIOUS INJURY TO THOSE PERSONS OR TO OTHERS.**

Subaru Service Bulletins are intended for use by professional technicians ONLY. They are written to inform those technicians of conditions that may occur in some vehicles, or to provide information that could assist in the proper servicing of the vehicle. Properly trained technicians have the equipment, tools, safety instructions, and know-how to do the job correctly and safely. If a condition is described, DO NOT assume that this Service Bulletin applies to your vehicle, or that your vehicle will have that condition.

**SUBARU OF AMERICA, INC. IS ISO 14001 COMPLIANT**

ISO 14001 is the international standard for excellence in Environmental Management Systems. Please recycle or dispose of automotive products in a manner that is friendly to our environment and in accordance with all local, state and federal laws and regulations.

- With the shifter in neutral, release the 6 retaining claws securing the center console / shifter trim. There are 2 claws in the back and 4 in the front. Release the 2 forward retaining claws at the sides of the forward console compartment.



**REAR**



**FRONT**

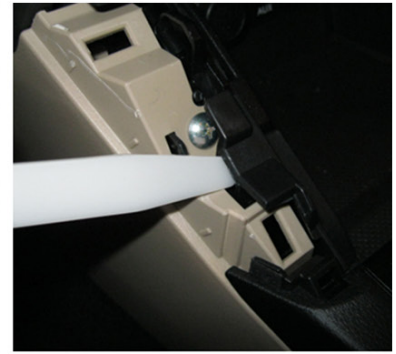

**FORWARD**

- Lift the trim panel, disconnect the wiring harness connectors and set the trim aside in a safe place to avoid damage.
- Remove the 2 front Philips screws and 2- 10mm hex bolts from under the plastic covers securing the console box in the back as shown in the illustration below. Once the hardware is removed, disconnect the wiring harness connectors and remove the console box. Place it upside-down on a clean, soft surface to protect the console lid soft trim from damage while performing the next steps.

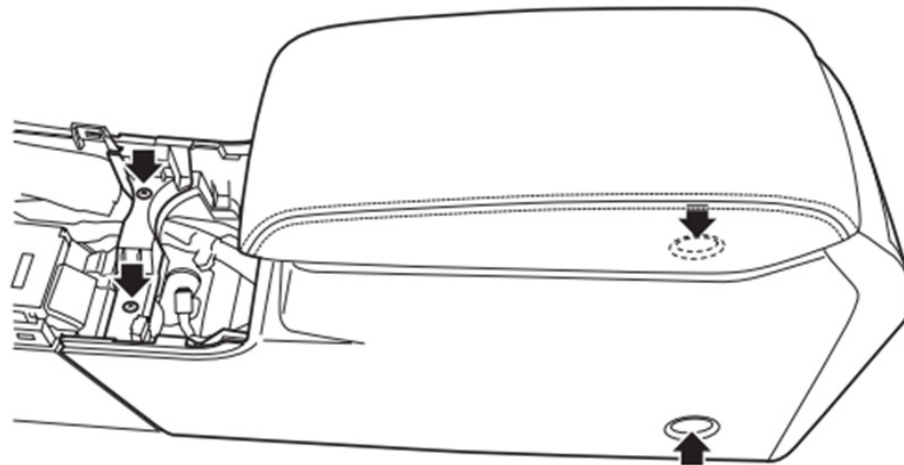

- Remove the 2 Philips screws securing the center duct and lift it out of the console box.

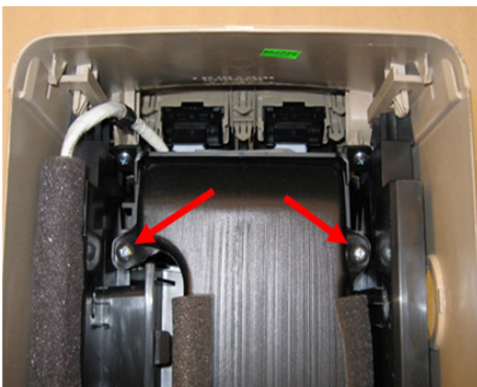

*Continued...*

- Identify the area of the center duct which fits inside the base of the vent grille assembly as shown in the photo and illustration below.

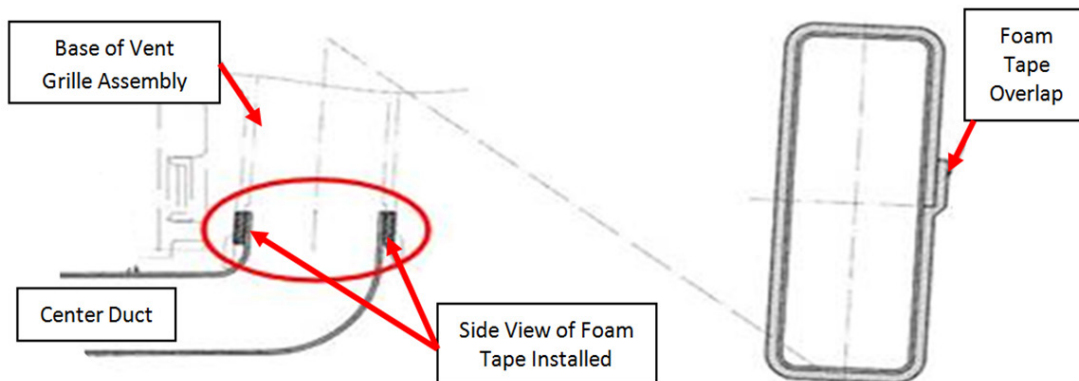

- Trial fit the foam tape making sure it wraps completely around the top edge of the center duct and overlaps by about ½ inch at the ends **on the back edge** as shown above.
- Clean the area where the foam tape will be applied with a mild solvent on a clean shop cloth. After drying, peel the adhesive backing and apply the foam tape flush with the top edge of the center duct as shown below. **IMPORTANT:** The overlap **must** be in the position shown below.

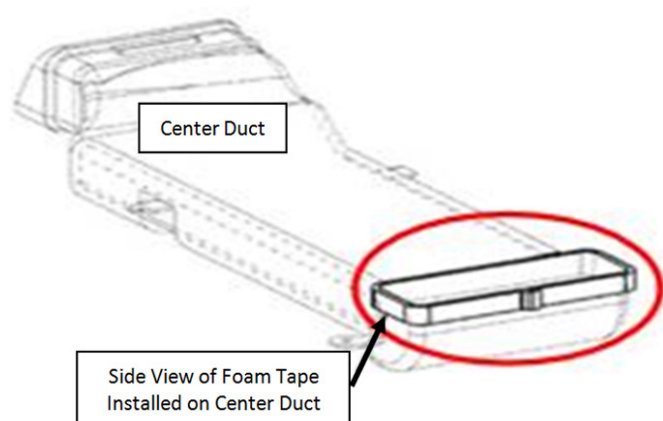

- Reinstall the center duct into the console box making sure the foam tape does not bunch up when refitting it back into the base of the vent grille assembly and reinstall the 2 Philips screws.
- Reinstall the console box and the related trim parts in the reverse order of removal.
- Reconnect all the removed wiring harness connectors.

*Continued...*



## IMPORTANT NOTES:

- After reinstalling the console box, confirm all the related electrical components operate completely **BEFORE** refitting the shifter trim panel.
- Make sure the rubber liner in the bottom of the forward console compartment is reinstalled properly along the front edge of the shifter trim panel or the door will not operate properly.

## WARRANTY / CLAIM INFORMATION

For vehicles within the Basic New Car Limited Warranty period, this repair may be claimed using the following information:

LABOR DESCRIPTION	LABOR OPERATION #	FAIL CODE	LABOR TIME
2015 Legacy & Outback Center Console Air Duct "Whistle Sound" Repair	A726-351	YNU-48	0.5

**NOTE:** Up to \$1.00 may be claimed in sublet to cover the cost of the foam tape.

**REMINDER:** SOA strongly discourages the printing and/or local storage of service information as previously released information and electronic publications may be updated at any time. **Always refer to STIS for the latest service information before performing any repairs.**