

**ATTENTION:**

GENERAL MANAGER   
 PARTS MANAGER   
 CLAIMS PERSONNEL   
 SERVICE MANAGER

IMPORTANT - All  
 Service Personnel  
 Should Read and  
 Initial in the boxes  
 provided, right.



QUALITY DRIVEN® SERVICE

## SERVICE BULLETIN

**APPLICABILITY:** 2013-16MY BRZ

**NUMBER:** 09-54-12R

**SUBJECT:** High-Pitched “Chirp,” “Squeak” or “Cricket”  
 Sound from the Engine

**DATE:** 10/03/12

**REVISED:** 09/27/16

### INTRODUCTION

This bulletin provides a procedure to address customer concerns of a high-pitched “chirp”, “squeak” or “cricket” sound heard coming from the engine’s Direct Injection (DI) high-pressure fuel pump. **Not all DI pumps may exhibit this sound.** Some vehicles may have components which in combination with certain fuel temperatures and / or formulations, may result in aeration of the fuel within the body of the pump and cause this sound. **This result is non-detrimental to the vehicle.** Production changes have been made to eliminate the source of the sound.

**IMPORTANT:** A “clack” or mechanical “ticking” sound also made by operation of the high-pressure fuel pump is considered to be a normal operating characteristic and no attempt should be made to repair it.

### PRODUCTION CHANGE AND PART APPLICABILITY INFORMATION:

Use both tables below for ordering and replacement of necessary parts according to the VIN.

VIN RANGE	REQUIRED PART REPLACEMENT(S)		
	DI Fuel Pump	Drive Case	Rocker Cover LH
Prior to F*603025	YES	YES	YES
F*603026 to F*603363	YES	NO	YES
F*603364 to G*604648	YES	NO	NO

*Continued...*

**CAUTION: VEHICLE SERVICING PERFORMED BY UNTRAINED PERSONS COULD RESULT IN SERIOUS INJURY TO THOSE PERSONS OR TO OTHERS.**

Subaru Service Bulletins are intended for use by professional technicians ONLY. They are written to inform those technicians of conditions that may occur in some vehicles, or to provide information that could assist in the proper servicing of the vehicle. Properly trained technicians have the equipment, tools, safety instructions, and know-how to do the job correctly and safely. If a condition is described, DO NOT assume that this Service Bulletin applies to your vehicle, or that your vehicle will have that condition.

**SUBARU OF AMERICA, INC. IS “ISO 14001 COMPLIANT”**

The international standard for excellence in Environmental Management Systems. Please recycle or dispose of automotive products in a manner that is friendly to our environment and in accordance with all local, state and federal laws and regulations.

**PART INFORMATION:**

PART NUMBER	DESCRIPTION	QUANTITY
16625JB021	DI Fuel Pump Assembly	1
16631AA030	Case Assembly, Pump Drive	1
13279AA430	Rocker Cover Assembly, LH	1
17540AA340*	Pipe Assy. Fuel Delivery (No. 2)	1
17555AA040*	Gasket, Fuel Pipe	1
14035AA610*	Gasket, Intake Manifold	2
16175AA420*	Gasket, Throttle Chamber	1
13272AA180*	Gasket, Rocker Cover	1
10966AA041*	Gasket, Spark Plug Tube	2

\* Denotes **ONE TIME USE** parts which **MUST** always be replaced.

\*\* **IMPORTANT-** See table above as parts are only applicable to some vehicles.

Always confirm applicability **BEFORE** ordering.

**PART IDENTIFICATION:**

**DI FUEL PUMP ASSEMBLY**

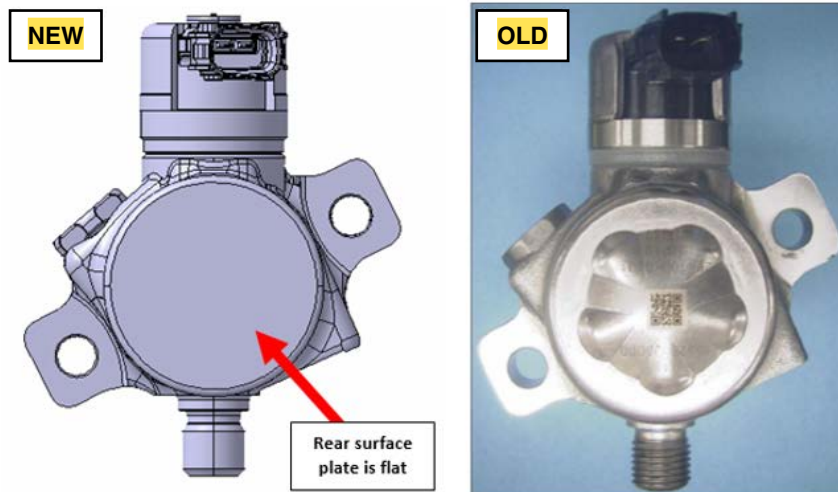

**PUMP DRIVE CASE ASSEMBLY (Check Table Above for Applicability)**

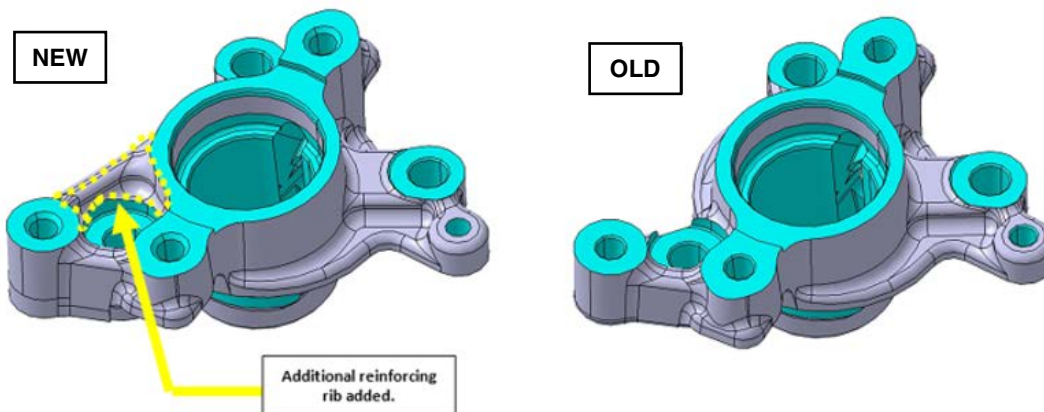

*Continued...*

**LH ROCKER COVER ASSEMBLY (Check Table Above for Applicability)**

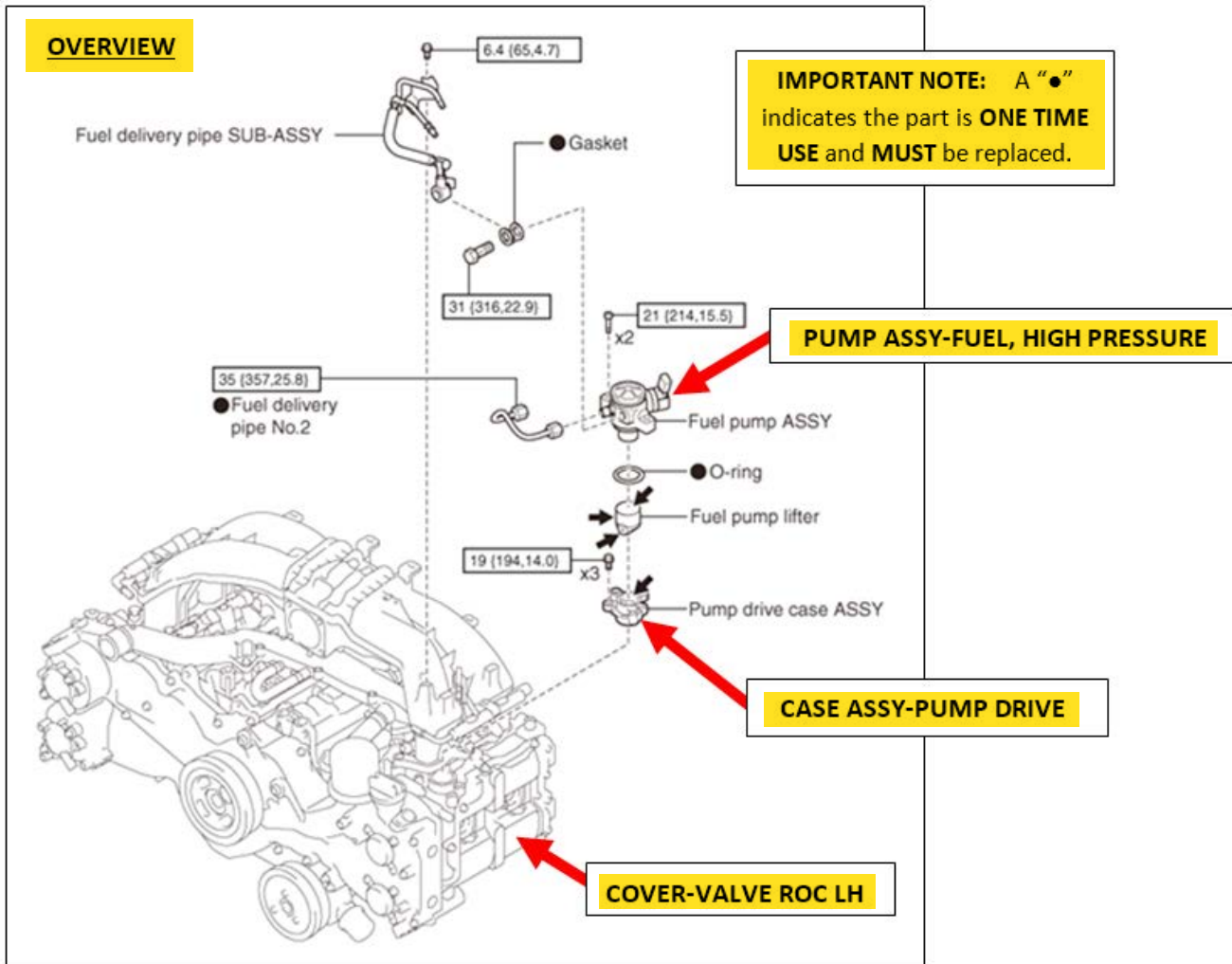
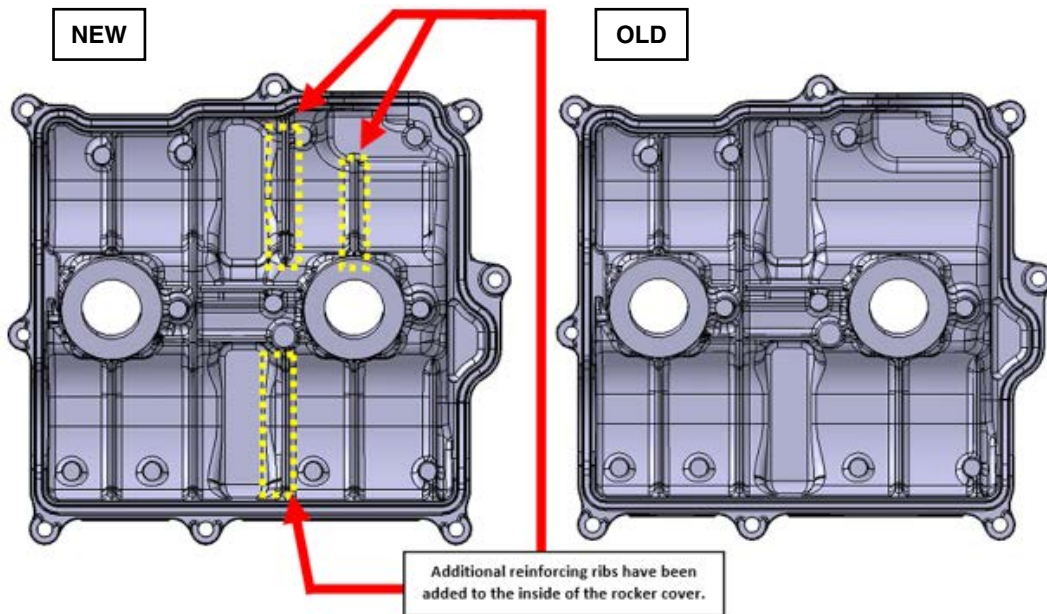

*Continued...*

**NOTES:**

- A new fuel pump sealing ring (o-ring) is included with the new pump assembly.
- The required tool for high-pressure fuel pump removal / installation is: Socket Driver, Snap-On Tools stock# **FTX40TPE, TORX® Plus, size 40 IP, length: 1¾”** (see July, 2012 TIPS).

**SERVICE PROCEDURE:**

Road test the vehicle at least 10 minutes to be sure it is up to operating temperature. Additional driving may be required to duplicate the condition in some cases depending upon the ambient temperatures and fuel quality. **Condition is generally observed during hot idle following driving such as at a fuel stop. Once the sound has been confirmed, follow all precautions and service procedures in the applicable Service Manual for replacing the high-pressure fuel pump and related components as required.**

**IMPORTANT:** Always follow all tightening torque specifications during re-assembly.

**WARRANTY / CLAIM INFORMATION**

For vehicles within the Basic New Car Limited or Powertrain Limited Warranty period or covered by an active Subaru Added Security Powertrain, Classic or Gold plan, this repair may be submitted using the following claim information:

Labor Description	Labor Operation #	Labor Time	Fail Code
BRZ DI High-Pressure Fuel Pump R&R	B442-191	1.7	DGI-25
BRZ DI Fuel Pump Drive Case R&R	C442-193	0.2	
BRZ LH Rocker Cover & Tube Seals R&R	C442-192	1.7	

**IMPORTANT REMINDERS:**

- SOA strongly discourages the printing and/or local storage of service information as previously released information and electronic publications may be updated at any time.
- Always check for any open recalls or campaigns anytime a vehicle is in for servicing.
- Always refer to STIS for the latest service information before performing any repairs.