



**NUMBER:** 05-001-17 REV. A

**GROUP:** Brakes

**DATE:** January 14, 2017

*This bulletin is supplied as technical information only and is not an authorization for repair. No part of this publication may be reproduced, stored in a retrieval system, or transmitted, in any form or by any means, electronic, mechanical, photocopying, or otherwise, without written permission of FCA US LLC.*

**THIS BULLETIN SUPERSEDES SERVICE BULLETIN 05-001-17, DATED JANUARY 12, 2017, WHICH SHOULD BE REMOVED FROM YOUR FILES. ALL REVISIONS ARE HIGHLIGHTED WITH **\*\*ASTERISKS\*\*** AND INCLUDE 2017 VEHICLES.**

***SUBJECT:***

Front Brake Squeak/Squeal Noise

***OVERVIEW:***

This bulletin involves cleaning excessive sealant from the front brake caliper adaptor brackets and replacing the adaptor bracket mounting bolts and/or replacing the front brake pads and related hardware.

***MODELS:***

2015 - <b>**2017**</b> (BU)	Jeep Renegade
2016 - <b>**2017**</b> (FB)	Fiat 500X

**NOTE: This bulletin applies to vehicles within the following markets/countries:  
NAFTA**

**NOTE: This bulletin applies to vehicles built on or before November 11, 2016 (MDH 1111XX).**

***SYMPTOM/CONDITION:***

The customer may describe one or more of the front brake squeak/squeal noise symptoms/conditions:

- Squeak/squeal noise during moderate brake apply combined with light steering. The noise typically occurs with warm brakes after several brake applications.
- Squeak/squeal noise during low speed brake apply with vehicle moving forward or reverse. The noise typically only occurs after the vehicle sits overnight in colder ambient temperatures and the noise will go away after a few brake applications.

***DIAGNOSIS:***

If the customer describes the symptom/condition listed above, perform the Repair Procedure.

**PARTS REQUIRED:**

Qty.	Part No.	Description
1	68353886AA	PAD KIT, Front Disc Brake, Includes Hardware
4 (AR)	68300566AA	BOLT, Hex Flange Head, M14X1.50X30.00 (Minimum Sales Quantity 4 Bolts) Only required for vehicles built on or before February 25, 2015.

**REPAIR PROCEDURE:**

1. Lift and support the vehicle. Refer to the detailed service procedures available in DealerCONNECT> TechCONNECT under: Service Info> 04 - Vehicle Quick Reference> Hoisting> Standard Procedure.
2. Remove the front wheels. Refer to the detailed service procedures available in DealerCONNECT> TechCONNECT under: Service Info> 22 - Tires and Wheels> Removal and Installation.

**NOTE: Perform this procedure on both right and left side of the vehicle.**

3. Loosen the brake caliper mounting guide pin bolts ([Fig. 1](#)).

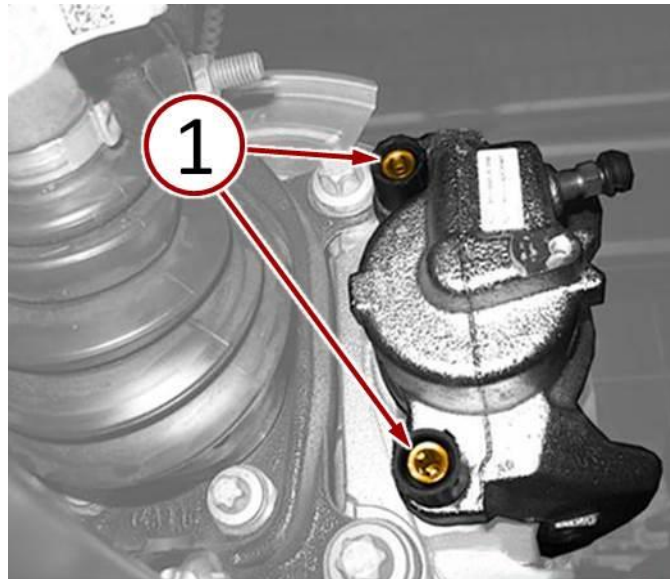

**Fig. 1 Loosen Brake Caliper Guide Pin Bolts**

**CAUTION: Support the brake caliper to prevent brake hose damage. Do NOT allow the brake caliper to hang from the brake hose.**

4. Remove the brake caliper from the brake caliper adaptor and support the brake caliper in order to prevent damage to the brake hose (Fig. 2).



**Fig. 2 Remove And Support Brake Caliper**

1 - Brake Caliper

---

5. Remove and discard the front brake pads.

**NOTE: Step #7 through Step #16 applies to vehicles built on or before February 25, 2015 (MDH 0225XX).**

6. Was vehicle built on or before February 25, 2015?
  - a. YES>>> Continue with Step #7.
  - b. NO>>> Proceed to Step #17.
7. Remove the brake caliper adaptor to front steering knuckle bolts (Fig. 3).
8. Remove the brake caliper adaptor bracket (Fig. 3).

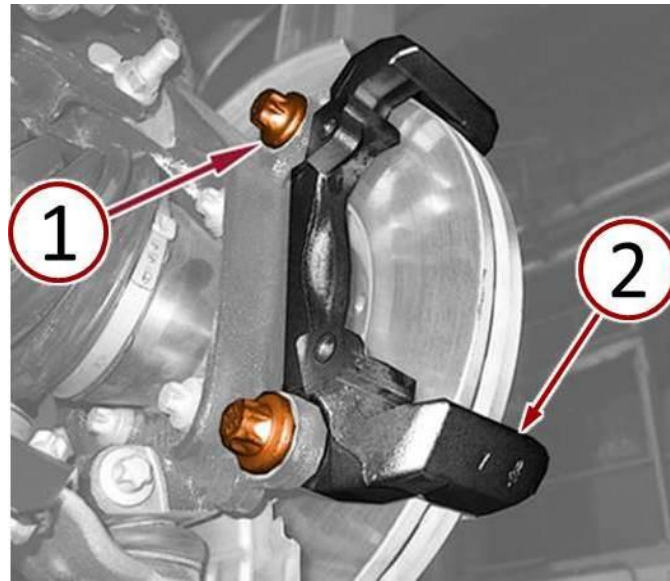

**Fig. 3 Remove Brake Caliper Adaptor Bracket**

- 1 - Brake Caliper Adaptor Bolts
- 2 - Brake Caliper Adaptor Bracket

- 
9. Mark the position of the brake rotor before removal.
  10. Remove the brake rotor retaining bolt (Fig. 4).
  11. Remove the brake rotor (Fig. 4).

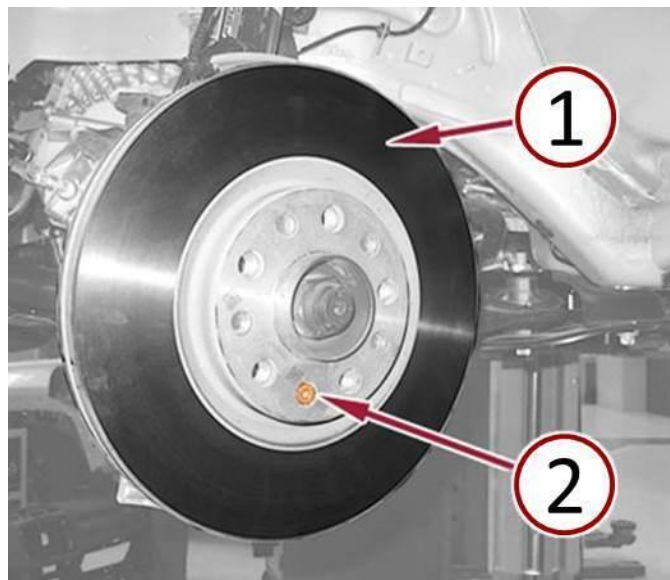

**Fig. 4 Remove Brake Rotor**

- 1 - Brake Rotor
  - 2 - Brake Rotor Retaining Bolt
-

12. Clean all the sealant from the contact surfaces between the brake calliper adaptor bracket and the steering knuckle (Fig. 5).

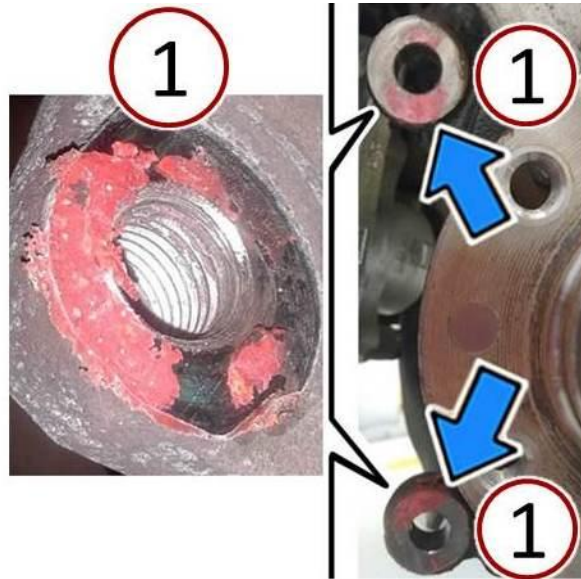

**Fig. 5 Clean Off Excess Sealant**

1 - Excess Sealant

- 
13. Install the brake rotor ensuring that the brake rotor is aligned with the previously created position alignment mark (Fig. 6).
  14. Install the brake rotor retaining bolt and tighten to 7 N·m (61 In. Lbs.) (Fig. 6).

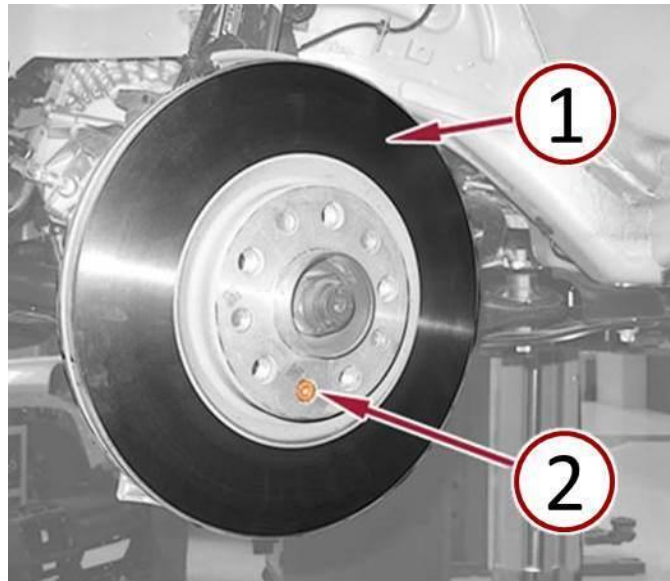

**Fig. 6 Install Brake Rotor**

- 1 - Brake Rotor
  - 2 - Brake Rotor Retaining Bolt
- 

15. Install the brake caliper adaptor bracket (Fig. 7).
16. Install the NEW brake caliper adaptor bolts and tighten to 165 N·m (122 Ft. Lbs.) (Fig. 7).

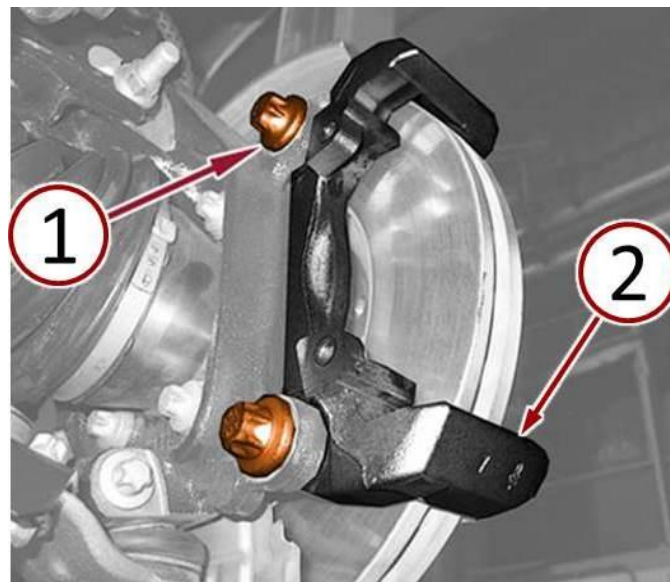

**Fig. 7 Install Brake Caliper Adaptor Bracket**

- 1 - Brake Caliper Adaptor Bolts
  - 2 - Brake Caliper Adaptor Bracket
-

17. Install the NEW revised front brake pads in the front brake pad kit from the Parts Required section of this bulletin.
18. Position the brake caliper onto the brake caliper adaptor ([Fig. 8](#)).

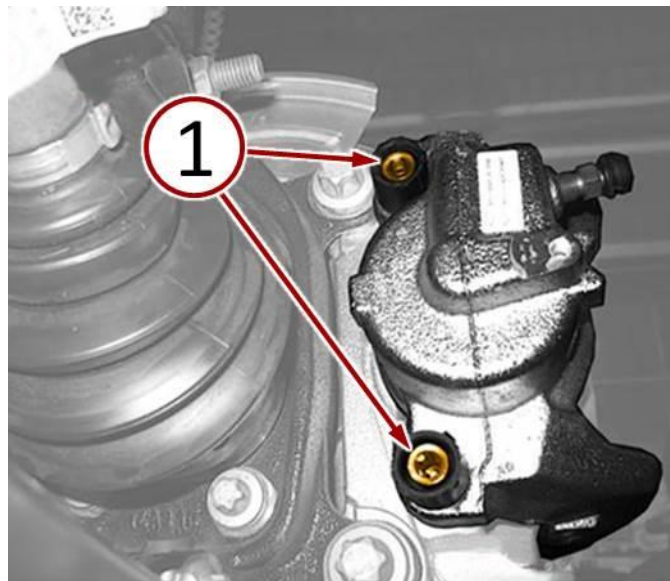

**Fig. 8 Install Brake Caliper With Inboard Brake Pad**

1 - Brake Caliper

---

19. Install the brake caliper mounting guide pin bolts and tighten to 27 N·m (20 Ft. Lbs.) ([Fig. 9](#)).



**Fig. 9 Tighten Brake Caliper Guide Pin Bolts**

1 - Brake Caliper Mounting Guide Pin Bolts

---

20. Install the front wheels. Refer to the detailed service procedures available in DealerCONNECT> TechCONNECT under: Service Info> 22 - Tires and Wheels> Removal and Installation.
21. Lower the vehicle.
22. Pump the brake pedal several times until caliper pistons and brake pads are seated and a firm brake pedal is obtained before moving the vehicle.
23. Check and adjust the brake fluid level in the reservoir as necessary.
24. Road test the vehicle and make several stops to wear off any foreign material on the brakes and to seat the brake pads and to verify that the customer's concern has been eliminated.

**POLICY:**

Reimbursable within the provisions of the warranty.

**TIME ALLOWANCE:**

Labor Operation No:	Description	Skill Category	Amount
05-70-22-9R	Pads, Disc Brake - Replace Front Set (2 - Skilled)	4 - Chassis Systems	0.6 Hrs.
05-70-22-9S	Pads, Disc Brake - Replace Front & Remove Sealant From Caliper Bracket Mounting Surfaces (2 - Skilled)	4 - Chassis Systems	0.9 Hrs.

**FAILURE CODE:**

ZZ	Service Action
----	----------------