



Service Bulletin

SERVICE UPDATE

SUBJECT: Service Update for Inventory and Customer Vehicles
Transmission Overfill
Expires with Base Warranty

MODELS: 2015-2016 Cadillac Escalade
2016 Cadillac ATS, CTS, Escalade ESV
2015 Chevrolet Silverado LD Ext LTZ
2015 Chevrolet Corvette
2015 GMC Yukon Denali
2016 GMC Yukon XL Denali
Equipped with Transmission M5U or M5N

This service update includes vehicles in dealer inventory and customer vehicles that return to the dealership for any reason. This bulletin will expire at the end of the involved vehicle's New Vehicle Limited Warranty period.

PURPOSE

This bulletin provides a service procedure to check and adjust transmission fluid levels on the vehicles listed above. These vehicles may expel extra transmission fluid out of a vent fitting and hose on the top of the transmission.

This service procedure should be completed as soon as possible on involved vehicles currently in dealer inventory and customer vehicles that return to the dealer for any type of service during the New Vehicle Limited Warranty coverage period.

VEHICLES INVOLVED

All involved vehicles are identified by VIN in the Global Warranty Management System – Investigate Vehicle History Application. Dealership technicians should always check this site to confirm vehicle involvement prior to beginning any required inspections and/or repairs. It is important to routinely use this tool to verify eligibility because not all similar vehicles may be involved regardless of description or option content.

Additionally, a list of involved vehicles currently in dealer inventory is available on the “Service Update Bulletin Information” link under the “Service” tab in GM GlobalConnect used to release this bulletin. Customer vehicles that return for service, for any reason, and are still covered under the vehicle's base warranty should also be checked for vehicle eligibility.

PART INFORMATION

No parts are required for this procedure.

SERVICE PROCEDURE

Caution: The transmission fluid level must be checked when the transmission fluid temperature (TFT) is between 35–45°C (95–113°F). If the TFT is not within this range, operate the vehicle or allow the fluid to cool as required. Setting the fluid level with a TFT outside this range will result in either an under or over-filled transmission. TFT>45°C=under-filled, TFT<35°C=over-filled. An under-filled transmission will cause premature component wear or damage. An over-filled transmission will cause fluid to discharge out the vent tube, fluid foaming, or pump cavitation.

1. Connect a scan tool to the vehicle.
2. Start and idle the engine.
3. In GDS, observe the TFT by navigating Module Diagnostics>Transmission Control Module>Automatic Transmission 8 Speed (M5U)>Data Display>Transmission Data.
4. Depress the brake pedal and move the shift lever through each gear range. Pause for at least 3 seconds in each range. Move the shift lever back to PARK. Ensure the engine RPM is low (500–800 RPM).
5. Raise and support the vehicle. The vehicle must be level, with the engine running and the shift lever in the PARK range. Refer to *Lifting and Jacking the Vehicle* in SI.

Warning: The transmission is overfilled with transmission fluid. Hot fluid will drain from the transmission when the oil level fill plug is removed. In addition, an over-filled transmission will cause fluid to discharge out the vent tube. Use caution when draining the transmission fluid.

Caution: THE ENGINE MUST BE RUNNING when the transmission fluid level check plug is removed; or excessive fluid loss will occur, resulting in an under-filled condition. An under-filled transmission will cause premature component wear or damage.

Note: Continue to monitor the TFT. If the TFT is not within the specified values, reinstall the transmission fluid level check plug and wait until TFT is within the specified range.

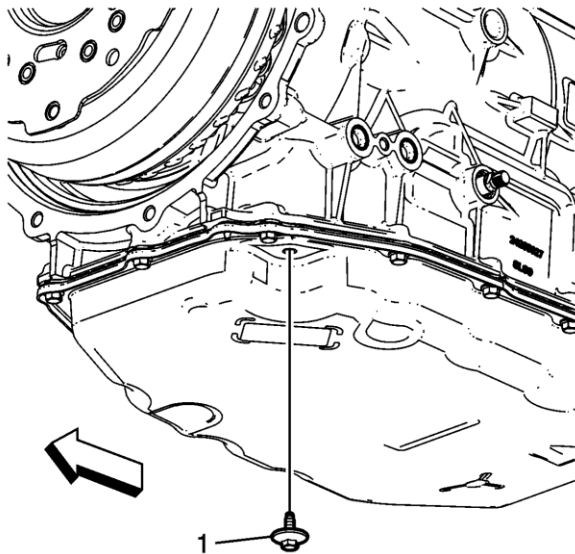

6. Check the transmission fluid level by removing the transmission oil level check plug. Refer to *Transmission Fluid Level and Condition Check* in SI.
7. Allow any fluid to drain until the fluid begins to drip.
8. Reinstall the transmission oil level check plug.
9. Clean off any excess fluid on the transmission fluid pan.
10. Lower the vehicle off of the hoist. Refer to *Lifting and Jacking the Vehicle* in SI.
11. Disconnect the scan tool.

WARRANTY TRANSACTION INFORMATION

Submit a transaction using the table below. All transactions should be submitted as a ZFAT transaction type, unless noted otherwise.

Labor Code	Description	Labor Time	Net Item
9101704	Transmission Fluid Level Check	0.3	N/A

DEALER PROGRAM RESPONSIBILITY

Whenever a vehicle subject to this service update enters your vehicle inventory, or is in your facility for service in the future, and the vehicle is still covered under the New Vehicle Limited Warranty, you must take the steps necessary to be sure the service update correction has been made before selling or releasing the vehicle.



GM CUSTOMER CARE AND AFTERSALES
DCS3755
URGENT - DISTRIBUTE IMMEDIATELY

Date: August 20, 2015

Subject: 15667 – Service Update Bulletin
Transmission Overfill

Models: 2015-2016 Cadillac Escalade
2016 Cadillac ATS, CTS, Escalade ESV
2015 Chevrolet Silverado LD Ext LTZ
2016 Chevrolet Corvette
2016 GMC Yukon Denali
2016 GMC Yukon XL Denali
Equipped with Transmission M5U or M5N

To: All General Motors Dealers

Attention: General Manager, Service Advisor, Service Manager, Parts and
Service Director, Parts Manager, New or Used Vehicle Sales
Manager, and Warranty Administrator

General Motors is releasing Service Update Bulletin 15667 today. The total number of U.S. vehicles involved is 16. Please see the attached bulletin for details.

Global Warranty Management (GWM)

The "Investigate Vehicle History" (IVH) screen will be updated by August 26, 2015. A list of involved vehicles in dealer inventory is attached to this message. hold all warranty transactions until the VIN appears in IVH.

END OF MESSAGE
GM CUSTOMER CARE AND AFTERSALES