



Service Bulletin



SPECIAL COVERAGE

SUBJECT: Special Coverage Adjustment – Unable to Remove Ignition Key

MODELS: 2005-2010 Chevrolet Cobalt
2006-2011 Chevrolet HHR
2006-2010 Pontiac Solstice
2007-2010 Pontiac G5
2005-2006 Pontiac G4/Pursuit
2007-2010 Saturn Sky
2003-2007 Saturn Ion
Equipped with Automatic Transmission

CONDITION

On some 2005-2010 model year (MY) Chevrolet Cobalt, 2006-2011 MY Chevrolet HHR; 2006-2010 MY Pontiac Solstice; 2007-2010 MY Pontiac G5; 2005-2006 MY Pontiac G4/Pursuit; 2007-2010 MY Saturn Sky and 2003-2007 MY Saturn Ion vehicles equipped with an automatic transmission, the vehicle's transmission shifter may not properly transmit an electrical signal that allows the ignition key to be turned counter clockwise past the accessory mode to the "LOCK" position after the vehicle has been shifted into park. If this occurs, the ignition key cannot be removed from the ignition cylinder without depressing the manual release plunger located on the underside of the steering column as described in the owner's manual. A key left in the accessory position for an extended period of time may result in severe battery drain and a possible no start condition.

SPECIAL COVERAGE ADJUSTMENT

This special coverage covers the condition described above for a period of 15 years from the date the vehicle was originally placed in service, regardless of vehicle mileage or ownership.

In most cases, dealers are to replace the automatic transmission shifter. This repair will be made at no charge to the customer. However, the service procedure also requires dealers to utilize the *Ignition Key Cannot Be Inserted, Rotated, or Removed from the Ignition Lock Cylinder* diagnostic information table in SI to eliminate other possible causes before replacing the automatic transmission shifter. This diagnosis and any related repairs are covered under this special coverage. Diagnosis or repair for conditions other than the condition described above is not covered under this special coverage.

For vehicles covered by Vehicle Service Contracts, all eligible claims with repair orders on or after December 11, 2014 are covered by this special coverage and must be submitted using the labor

operation codes provided with this bulletin. Claims with repair orders prior to December 11, 2014 must be submitted to the Service Contract provider.

VEHICLES INVOLVED

All involved vehicles are identified by Vehicle Identification Number on the Applicable Warranties section in GM Global Warranty Management system. Dealership service personnel should always check this site to confirm vehicle involvement prior to beginning any required inspections and/or repairs. It is important to routinely use this tool to verify eligibility because not all similar vehicles may be involved regardless of description or option content.

PART INFORMATION

Parts required to complete this special coverage are to be obtained from General Motors Customer Care and Aftersales (GMCCA).

Part Number	Description	Quantity/Vehicle	Color
15793413	SOLENOID ASM, A/TRNS SHFT LK CONT (2003-2007 Ion)	1 (If Required)	No Color
15835451	CONTROL ASM, A/TRNS (2003-2004 Ion)	1 (If Required)	No Color
15793389	CONTROL ASM, A/TRNS (2005-2007 Ion)	1 (If Required)	No Color
15926820	CONTROL ASM, A/TRNS (2005-2008 Cobalt, G5, G4, Pursuit)	1 (If Required)	No Color
20820709	CONTROL ASM, A/TRNS (2008-2010 Cobalt, G5, HHR, Pursuit)	1 (If Required)	No Color
25864102	CONTROL ASM, A/TRNS (W/ A/TRNS CONT IND) (2006-2008 HHR)	1 (If Required)	No Color
25864103	CONTROL ASM, A/TRNS (W/ A/TRNS CONT IND) (2006-2008 HHR)	1 (If Required)	No Color
20820710	CONTROL ASM, A/TRNS (2009-2011 HHR)	1 (If Required)	No Color
20772038	CONTROL ASM, A/TRNS (2009 Solstice)	1 (If Required)	Inferno Orange
20756030	CONTROL ASM, A/TRNS (2007-2009 Solstice)	1 (If Required)	Cobalt Red
20756032	CONTROL ASM, A/TRNS (2008-2010 Solstice)	1 (If Required)	Omni Khaki
15777204	CONTROL ASM, A/TRNS (2006-2010 Solstice, Sky)	1 (If Required)	No Color
20756031	CONTROL ASM, A/TRNS (2007-2010 Sky)	1 (If Required)	Omni Khaki
20778934	CONTROL ASM, A/TRNS (2009-2010 Sky)	1 (If Required)	Hydro Blue
20756029	CONTROL ASM, A/TRNS (2007-2010 Sky)	1 (If Required)	Cobalt Red

SERVICE PROCEDURE

Note: Check the Investigate Vehicle History (IVH) screen in the GM Global Warranty Management (GWM) system to ensure the required repair for either recall 14113 or recall 14133 has been completed. Vehicles involved in special coverage 14632 were also involved in one or the other of these previous recalls.

- If the repair for recall 14113 or recall 14133 has NOT been completed, complete the required repair BEFORE proceeding to step #1 in this bulletin.
 - If the repair for recall 14113 or recall 14133 has been completed, proceed to step #1 in this bulletin.
1. Perform an ignition lock cylinder function test. Determine if the ignition key can be inserted, rotated, and removed from the ignition lock cylinder.
 - If the ignition key can be inserted, rotated and removed from the ignition lock cylinder without engaging the release button, no further action is required.

Note: It is essential to read and follow the *Ignition Key Cannot Be Inserted, Rotated, or Removed from the Ignition Lock Cylinder* diagnostic information table in SI to correctly root cause the condition. In addition, refer to Technical Service Bulletin 06-07-30-004G and Technical Service Bulletin 09-02-35-005C for important service information. If the lock cylinder and ignition key were replaced in either recall 14113 or recall 14133, a floor shifter replacement or shift control cable adjustment may be required.

- If the ignition key cannot be inserted, rotated and removed from the ignition lock cylinder, refer to *Ignition Key Cannot Be Inserted, Rotated, or Removed from the Ignition Lock Cylinder* in SI.

Note: If diagnosis indicates that a lock cylinder, lock cylinder housing, ignition key or ignition solenoid requires replacement, determine if the parts were damaged because of a workmanship issue related to the completion of recall 14113 or recall 14133. If any of these parts were damaged because of a workmanship issue related to the completion of recall 14113 or recall 14133, their replacement will be covered under one or the other of these previous recalls, whichever is applicable, but will require wholesale authorization.

2. If the diagnostic table leads to a floor shifter replacement recommendation, proceed to *Transmission Control Replacement Procedure*, below.

TRANSMISSION CONTROL REPLACEMENT PROCEDURE

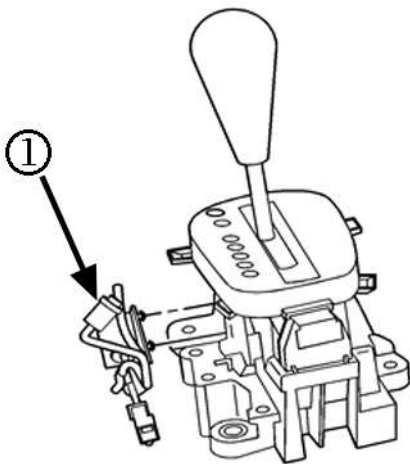

4043711

Important: For Ion models only, refer to *Diagnostic Starting Point - Automatic Transmission Shift Lock Control* and as necessary, *Shift Lock Control Solenoid (1) Replacement* in SI.

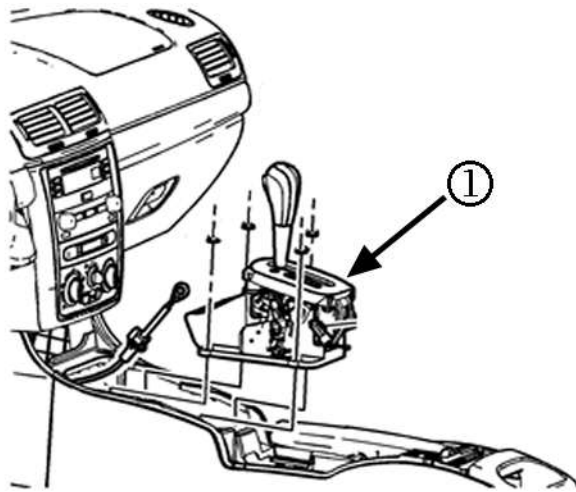

4043712

1. Remove the floor shifter (1). Refer to *Transmission Control Replacement* in SI.
2. Install the new floor shifter. Refer to *Transmission Control Replacement* in SI.

CUSTOMER REIMBURSEMENT - For U.S.

Customer requests for reimbursement of previously paid repairs to correct the condition described in this bulletin are to be submitted to the dealer by December 31, 2015, unless otherwise specified by state law. If this is not convenient for the customer, they may mail the completed Customer Reimbursement Request Form and all required documents to the GM Customer Assistance Center. Repairs must have occurred within 15 years from the date the vehicle was originally placed in service, regardless of vehicle mileage.

All reasonable and customary costs to correct the condition described in this bulletin should be considered for reimbursement. Any questions or concerns should be reviewed with your GM representative prior to processing the request.

When a customer requests reimbursement, they must provide the following:

- A completed Customer Reimbursement Request Form. This form is mailed to the customer or can be obtained through GM GlobalConnect.
- The name and address of the person who paid for the repair.
- Paid receipt confirming the amount of the repair expense, a description of the repair, and the person or entity performing the repair.

IMPORTANT: GM requires dealers to approve or deny a reimbursement request within 30 days of receipt. If a reimbursement request is approved, the dealer should immediately issue a check to the customer and submit an appropriate warranty transaction for the incurred expense. If a reimbursement request is denied, the dealer MUST provide the customer with a clear and concise explanation, in writing, as to why the request was denied. The bottom portion of the Customer Reimbursement Request Form may be used for this purpose. If the denial was due to missing documents, the customer can resubmit the request when the missing documents are obtained, as long as it is still within the allowed reimbursement period.

Warranty transactions for customer reimbursement of previously paid repairs are to be submitted as required by GM Global Warranty Management. Additional information can also be found in Warranty Administration Bulletin 11-00-89-004.

CUSTOMER REIMBURSEMENT - For Canada and Export

Customer requests for reimbursement of previously paid repairs to correct the condition described in this bulletin are to be submitted to the dealer prior to or by December 31, 2015. Repairs must have occurred within 15 years from the date the vehicle was originally placed in service, regardless of vehicle mileage.

When a customer requests reimbursement, they must provide the following:

- Proof of ownership at time of repair.
- Original paid receipt confirming the amount of unreimbursed repair expense(s) (including Service Contract deductibles), a description of the repair, and the person or entity performing the repair.

All reasonable and customary costs to correct the condition described in this bulletin should be considered for reimbursement. Any questions or concerns should be reviewed with your GM representative prior to processing the request.

COURTESY TRANSPORTATION – For U.S. and Canada

The General Motors Courtesy Transportation program is intended to minimize customer inconvenience when a vehicle requires a repair that is covered by the New Vehicle Limited Warranties. The availability of courtesy transportation to customers whose vehicles are within the warranty coverage period and involved in a product program is very important in maintaining customer satisfaction. Dealers are to ensure that these customers understand that shuttle service or some other form of courtesy transportation is available and will be provided at no charge. Dealers should refer to the General Motors Service Policies and Procedures Manual for Courtesy Transportation guidelines.

WARRANTY TRANSACTION INFORMATION

Submit a transaction using the table below. All transactions should be submitted as a ZREG transaction type, unless noted otherwise.

Note: To avoid having to "H" route the customer reimbursement transaction for approval, it must be submitted prior to the repair transaction.

Labor Code	Description	Labor Time	Net Item
9900111	Diagnostic Time - Condition Not Covered Under This Special Coverage - No Repair Required	0.1-0.3	N/A
9900112	Shift Cable Adjustment Cobalt, G5, Ion, HHR, G4, Pursuit Solstice, Sky Add: Diagnostic Time	0.4 0.5 0.1-0.3	N/A
9900113	Connector Reconnection - All Add: Diagnostic Time	0.1-0.5 0.1-0.3	N/A
9900114	Transmission Control Replacement Cobalt, G5, Ion, G4, Pursuit HHR Solstice, Sky Add: Shift Lock Control Solenoid Replacement - Ion Only Add: Diagnostic Time	0.6 1.0 1.4 0.1 0.1-0.3	N/A
9900115	Customer Reimbursement Approved	0.2	*
9900116	Customer Reimbursement Denied - For U.S. dealers only	0.1	N/A

* The amount identified in "Net Item" should represent the dollar amount reimbursed to the customer.

CUSTOMER NOTIFICATION

General Motors will notify customers of this special coverage on their vehicles (see copy of typical customer letter included with this bulletin - actual divisional letter may vary slightly).



December 2014

Dear General Motors Customer:

As the owner of a 2005-2010 model year (MY) Chevrolet Cobalt, 2006-2011 MY Chevrolet HHR; 2006-2010 MY Pontiac Solstice; 2007-2010 MY Pontiac G5; 2005-2006 MY Pontiac G4/Pursuit; 2007-2010 MY Saturn Sky or 2003-2007 MY Saturn Ion vehicle equipped with an automatic transmission, your satisfaction with our product is very important to us.

This letter is intended to make you aware that your vehicle's transmission shifter may not properly transmit an electrical signal that allows the ignition key to be turned counter clockwise past the accessory mode to the "LOCK" position after the vehicle has been shifted into park. If this occurs, the ignition key cannot be removed from the ignition cylinder without depressing the manual release plunger located on the underside of the steering column as described in the owner's manual. A key left in the accessory position for an extended period of time may result in severe battery drain and a possible no start condition.

Do not take your vehicle to your GM dealer as a result of this letter unless you believe that your vehicle has the condition as described above.

What We Have Done: General Motors is providing owners with additional protection for the condition described above. If this condition occurs on your vehicle within 15 years of the date your vehicle was originally placed in service, regardless of vehicle mileage, the condition will be repaired for you at **no charge**. Diagnosis or repair for conditions other than the condition described above is not covered under this special coverage program.

What You Should Do: If you believe that your vehicle has the condition described above, repairs and adjustments qualifying under this special coverage must be performed by a General Motors dealer. You may want to contact your GM dealer to find out how long they will need to have your vehicle so that you may schedule the appointment at a time that is convenient for you. This will also allow your dealer to order parts if they are not already in stock. Keep this letter with your other important glove box literature for future reference.

Reimbursement: If you have paid for repairs for the condition described in this letter, please complete the enclosed reimbursement form and present it to your dealer with all required documents. Working with your dealer will expedite your request, however, if this is not convenient, you may mail the completed reimbursement form and all required documents to Reimbursement Department, PO Box 33170, Detroit, MI 48232-5170. The completed form and required documents must be presented to your dealer or received by the Reimbursement Department by December 31, 2015, unless state law specifies a longer reimbursement period.

If you have any questions or need any assistance, just contact your dealer or the appropriate Customer Assistance Center at the number listed below.

Division	Number	Text Telephones (TTY)
Chevrolet	1-800-222-1020	1-800-833-2438
Pontiac	1-800-762-2737	1-800-833-7668
Saturn	1-800-553-6000	1-800-833-6000
Guam	65-6267-1752	
Puerto Rico – English	1-800-496-9992	
Puerto Rico – Español	1-800-496-9993	
Virgin Islands	1-800-496-9994	

We are sorry for any inconvenience you may experience; however, we have taken this action in the interest of your continued satisfaction with our products.

Alicia S. Boler-Davis
Sr. Vice President
Global Quality & Customer Experience

Enclosure
14632

GM CUSTOMER CARE AND AFTERSALES
DCS3478
URGENT - DISTRIBUTE IMMEDIATELY

Date: December 11, 2014

Subject: 14632 – Special Coverage Adjustment
Unable to Remove Ignition Key

Models: 2005-2010 Chevrolet Cobalt
2006-2011 Chevrolet HHR
2006-2010 Pontiac Solstice
2007-2010 Pontiac G5
2005-2006 Pontiac G4/Pursuit
2007-2010 Saturn Sky
2003-2007 Saturn Ion
Equipped with Automatic Transmission

To: All General Motors Dealers

Attention: General Manager, Service Advisor, Service Manager, Parts and
Service Director, Parts Manager, Used Vehicle Sales Manager,
and Warranty Administrator

General Motors is releasing Special Coverage Adjustment 14632 today. The total number of U.S. vehicles involved is approximately 1.9 million. Please see the attached bulletin for details.

Customer Letter Mailing

The customer letter mailing will begin on December 15, 2014.

Global Warranty Management (GWM)

The Investigate Vehicle History screen in GWM will be updated in the near future.

Campaign Initiation Detail Report (CIDR)

The CIDR is not available for Special Coverage Adjustments.

END OF MESSAGE

GM CUSTOMER CARE AND AFTERSALES